

## TEACHER'S GUIDE<sup>™</sup>

### REAL BRIDGE BUILDING<sup>™</sup>

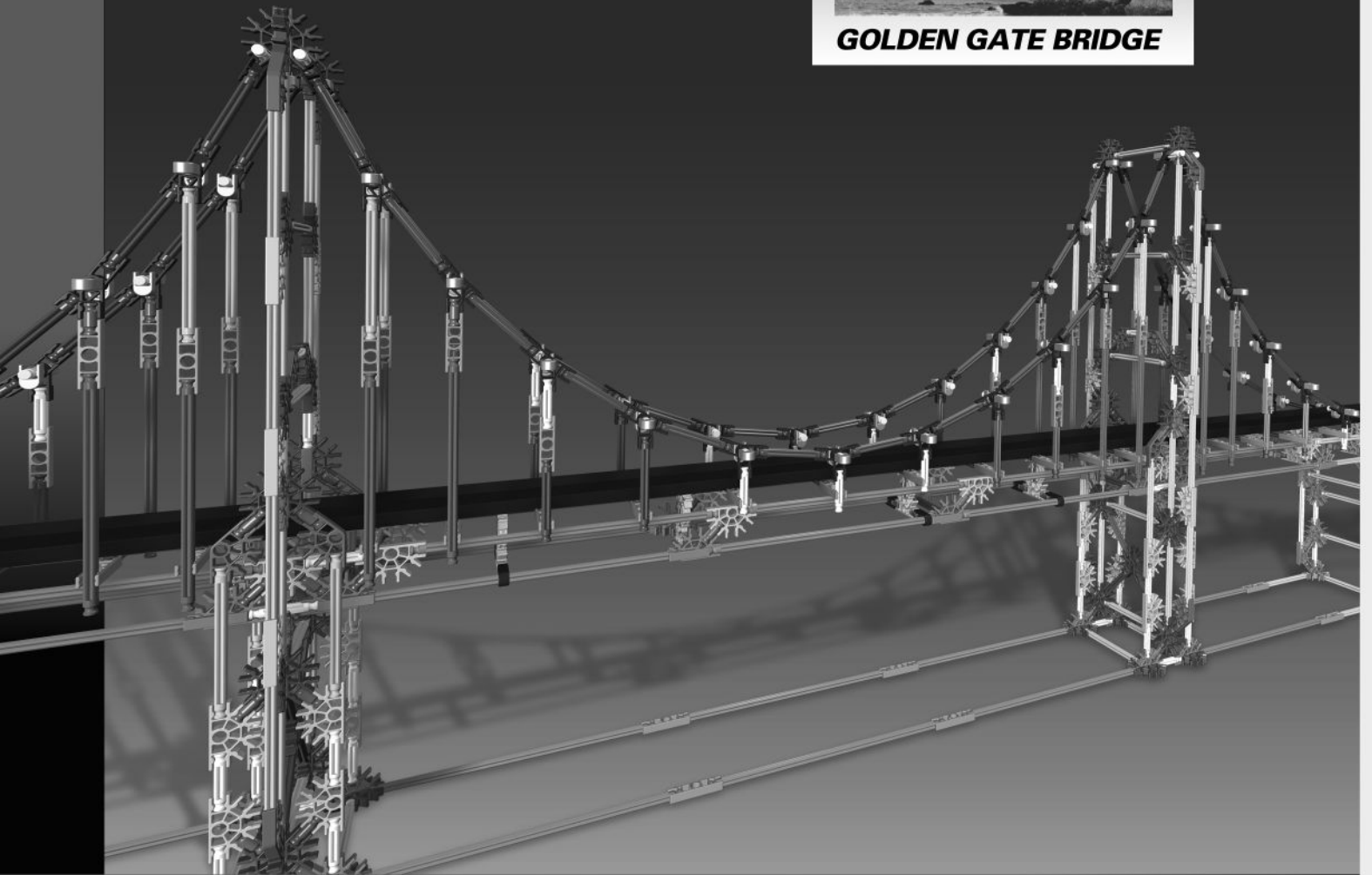

**GOLDEN GATE BRIDGE**





# REAL BRIDGE BUILDING Teacher's Guide

V3-03/11

©2011 K'NEX Limited Partnership Group  
and its licensors.

K'NEX Limited Partnership Group  
P.O. Box 700  
Hatfield, PA 19440-0700

K'NEX is a registered trademark of  
K'NEX Limited Partnership Group.  
Protected by International Copyright.  
All rights reserved.

Visit our website at [www.knexeducation.com](http://www.knexeducation.com)  
Email: [abcknex@knex.com](mailto:abcknex@knex.com)  
Phone: 1-888-ABC-KNEX (Toll Free)

Text:

Dr. Alex Wright  
AW Education, Wrexham, LL12 7LR. U.K.

Acknowledgements:

The author would like to thank Matthew Haines (M.S. Educational Technology,) Assistant Principal, Souderton Area High School, Souderton PA, for his valuable contributions; these helped align the activities in this Guide to US Science and Technology curricula. Additionally, Reader #4 draws on material developed by him for use in a Technology Education curriculum unit on Structures.

## A NOTE ABOUT SAFETY:

Safety is of primary concern in science and technology classrooms. It is recommended that you develop a set of rules that governs the safe, proper use of K'NEX in your classroom.

Caution students to keep hands and hair away from all moving parts. Never put fingers in moving Gears or other moving parts.



### WARNING:

CHOKING HAZARD - Small parts.  
Not for children under 3 years.



### AVERTISSEMENT :

DANGER D'ÉTOUFFEMENT - Pièces de petite taille.  
Ne convient pas aux enfants de moins de 3 ans.

# Table of Contents

## TABLE OF CONTENTS

<b>Introduction</b>	<b>2-3</b>	6. Spanning Gaps: Beams or Arches?	103-105
<b>How to Use the K'NEX Real Bridge Building Curriculum Materials</b>	<b>4</b>	7. Investigating Cantilevers	106-113
		8. Investigating Suspension Bridges	114-117
<b>Readers</b>	<b>5-35</b>	<b>SECTION II: CASE STUDY OF A BRIDGE DESIGN</b>	
1. What Is The Function Of A Bridge?	5-6	Teacher's Notes	118-121
2. Bridges and Forces 1: The Basics	7-8	<b>SECTION III: A BRIDGE CONSTRUCTION PROJECT: AN EXERCISE IN TEAMWORK PLANNING AND IMPLEMENTATION</b>	
3. Bridges and Forces 2: Beams and Columns	9-13	Teacher's Notes	122-124
4. Stress, Strain, Stiffness and Young's Modulus	14-17	<b>SECTION IV: WORKING AS DESIGN ENGINEERS: THE K'NEX PEDESTRIAN BRIDGE PROJECT</b>	
5. Making Strong Structures	18-23	Teacher's Notes	125-127
6. Different Types of Bridges	24-35	Design Engineering Guidelines For Students <i>(For Photocopying)</i>	128-132
<b>SECTION I: SKILL BUILDERS</b>		Suppliers Price List and Order Form <i>(For Photocopying)</i>	133
<b>Teacher's Notes</b>	<b>36-80</b>	<b>SECTION V: AN INTERDISCIPLINARY ACTIVITY FOR REAL BRIDGE BUILDING</b>	
An Overview	36	Teacher's Notes	134-138
1. Building a Bridge Can't Be All That Difficult, Can It?	37-39	<b>GLOSSARY</b>	<b>139-141</b>
2. Investigating 2-D Shapes: Rectangles and Squares	40-44	<b>ADDITIONAL READING/ RESOURCE LIST FOR STUDENTS</b>	<b>142</b>
3. Investigating 2-D Shapes: Triangles	45-49	<b>USEFUL WEB SITES</b>	<b>143</b>
4. Strengthening 2-D Shapes	50-54		
5. Making 3-D Frame Structures: Cubes	55-61		
6. Spanning Gaps: Beams or Arches?	62-67		
7. Investigating Cantilevers	68-74		
8. Investigating Suspension Bridges	75-80		
<b>Student Inquiry Worksheets</b> <i>(For Photocopying)</i>			
1. Building a Bridge Can't Be All That Difficult, Can It?	81-82		
2. Investigating 2-D Shapes: Rectangles and Squares	83-86		
3. Investigating 2-D Shapes: Triangles	87-90		
4. Strengthening 2-D Shapes	91-95		
5. Making 3-D Frame Structures: Cubes	96-102		



# Introduction

## Overview

*This Teacher's Guide has been developed to support you as your students use the K'NEX Education Real Bridge Building Set to investigate famous bridges from around the world. Using the K'NEX materials provided and maintaining a comprehensive journal will enable your students to develop their knowledge and understanding of structures through the context of seven different bridge designs with varied histories. The materials included in this Guide offer you a wide choice of activities and extensive background information to enhance your understanding of the scientific, technological, and mathematical concepts related to the bridges your students will be studying. The resource information is provided for your benefit as you present the materials and to assist you in answering student questions that may arise during discussions in the classroom. The versatility of the K'NEX Real Bridge Building Set allows it to be used across a wide range of grade levels and subject areas, including college-level civil engineering classes. As a result, you may find that some materials included in this Guide are less suitable than others for the middle school learner. You are the best judge of what is appropriate to meet the needs of the students you serve.*

## K'NEX REAL BRIDGE BUILDING

This K'NEX construction set is designed to assist students in their study of the history, function, structural design, geometry and strength of bridges. An investigation of bridges will help students learn and experiment with the forces affecting all structures. They will also investigate concepts related to the physical properties of materials and their application in the placement, design, and construction of bridges. Bridge building requires complex engineering solutions that are based on sound mathematical and scientific concepts.

As students use this K'NEX set they will have the opportunity to acquire skills through a hands-on, inquiry-based approach to information and concepts. Working cooperatively, students are encouraged to interact with each other as they build, investigate, problem solve, brainstorm, discuss, and evaluate scientific and technological design principles in action.

## TEACHER'S GUIDE

Intended as a resource for the teacher, the Guide contains the following sections:

- **How to Use the K'NEX Real Bridge Building Curriculum Materials:** This schematic offers a visual overview of the five types of activities included in the Guide and suggests a roadmap that you may wish to follow as you introduce them into your classroom. The schematic demonstrates how the activities can be used sequentially or individually in the manner that best fits your own teaching program for this area of the curriculum.
- **Readers:** These provide background information on the factors engineers take into consideration as they design bridges. Topics covered by the six Readers include the engineering principles that have been applied to allow bridges to support the loads they must carry, the materials used in their construction, and an overview of the characteristic features of the main types of bridges. Fully illustrated with diagrams and photographs, the Readers are designed for use by both teachers and students; those that include concepts more appropriate for upper grade levels have been identified. It is anticipated that the Readers will be photocopied and made available for assigned reading or as resources for research projects.

# Introduction

- **Teacher's Notes:** These are provided for Section I: Skill Building; Section II: Case Study of a Bridge Design; Section III: A Bridge Construction Project; Section IV: Working as Design Engineers; and Section V: An Interdisciplinary Activity for Real Bridge Building. Student objectives are identified and scripts, with background notes, are provided to assist you, the teacher, as you present each activity associated with the bridge models. Most of the activities can be completed in 30-45 minutes after the bridges have been constructed. Bridge construction can be a time consuming task but the rewards, in terms of the cooperative learning and problem solving aspects of the project, as well as the pride derived from the successful completion of one of the massive bridges, are deemed well worth the effort and the time. There are also extension activities that can be used to explore in greater depth the concepts associated with the various activities. We recommend that you review your curriculum and state standards to identify which of the activities provided in the Guide best meet the needs of your students.
- **Student Inquiry Sheets:** These are provided for Section I: Skill Builders and Section IV: Working as Design Engineers. In the Skill Builders section, each Inquiry Sheet provides an introduction to the activity, a materials list, step-by-step guidelines for undertaking the investigation, and a series of questions to help students focus their observations. Students are expected to record their observations in their journals, using annotated drawings and notes (see below). The Inquiry Sheets should be photocopied so that, at a minimum, every group of 2-3 students has a copy.
- **Glossary:** A comprehensive list of key terms and definitions associated with structures, in general, and bridges, in particular.
- **Additional Reading/Resource list for Students:** A short reading list to take your students further and for them to use in research projects.
- **Useful Web Sites:** This list is intended for use by the teacher, but it could be reproduced and made available to students for research. The sites were active at the time of going to press.
- **CD-ROM of Building Instructions:** This contains the Building Instructions files for each of the K'NEX Real Bridges and acts as a supplement to the colored Building Instruction booklets that accompany the set. The files may be printed and distributed to students to facilitate group construction of the model bridges.

## STUDENT JOURNALS

It is expected that students will have journals available to record information, thoughts, and investigations. They should be encouraged to enter their initial thoughts as they begin each inquiry. These initial thoughts may be amended, based on their on-going inquiry and analysis, until the student is able to draw informed conclusions. The students' journal entries will assist them as they make connections between the behavior of their models during experiments and the bridges the models represent. In addition, their written responses will encourage the use of newly learned vocabulary associated with structures, and will provide an opportunity for them to write across the curriculum. The journals also offer a place for students to practice drawing annotated diagrams of bridges and their structural components. Finally, the journals serve as an **assessment vehicle** for the bridges unit.





# How To Use The K'NEX Real Bridge Building Curriculum Materials

## II

### Case Study of a Bridge Design

A collaborative investigation for 4 - 6 students. Students investigate and evaluate the design of a named bridge. The K'NEX Real Bridge Building set provides examples of 7 famous bridge designs, some of which needed innovative engineering solutions to solve the problems caused by the location and the need to safely span longer and longer gaps. Provides opportunities for cross-curricular links to:

- Information Technology – using the Internet for searches within set parameters; working as part of a team on a multimedia presentation.
- Geography - the impact of bridges on local economies, and on human and ecological environments.
- History - tracing the technological developments in bridge design and construction materials.
- Civics – understanding the planning process and funding issues involved in large-scale projects.

## III

### Bridge Construction: An Exercise in Teamwork, Planning and Implementation

A project team of 4 – 6 students must plan and organize their activities to complete the construction of a large-scale K'NEX Real Bridge model within a limited time scale. They adopt the roles of construction engineers who must turn 2-D designs into 3-D reality. To complete the task students must:

- Analyze the building plans of a K'NEX Real Bridge model.
- Assign tasks and roles to team members.
- Work collaboratively to:
  - Formulate a construction plan.
  - Implement the construction plan.
  - Evaluate their performance.

## Skill Builder Activities

Progressive investigations to develop students' knowledge and understanding of the following:

### Key Concepts

- The effect of forces on 2-D and 3-D shapes and materials.
- Use of triangulation to strengthen frame structures.
- Strength of structures and materials.
- Stress, strain, stiffness and Young's modulus.
- Using technical and scientific vocabulary in context.
- How key concepts are applied in the design and construction of structures – Real Bridges.

### Key Skills

- 3-D spatial awareness.
- Team building skills.
- Problem solving skills.
- Modeling, testing, evaluating and modifying their ideas as part of the design process.
- Interpreting 2-D drawings to make 3-D models and to make their own 2-D drawings and plans from 3-D models.

## IV

### Working as Design Engineers: The K'NEX Pedestrian Bridge Project

A whole class activity in which teams take on the roles of design engineering companies.

Students develop a range of key skills through working on a design project in which they:

- Design a bridge to meet a client's specifications and company profit parameters.
- Draw plans.
- Cost the project to include materials and construction time.
- Plan its construction, in competition with other class-based companies.

## V

### Interdisciplinary Activity

Using the Real Bridge Building set as a foundation, this activity allows science and mathematics teachers or technology and mathematics teachers to work together to enhance students' understanding of the math and science concepts related to suspension bridges.

## Starting Point

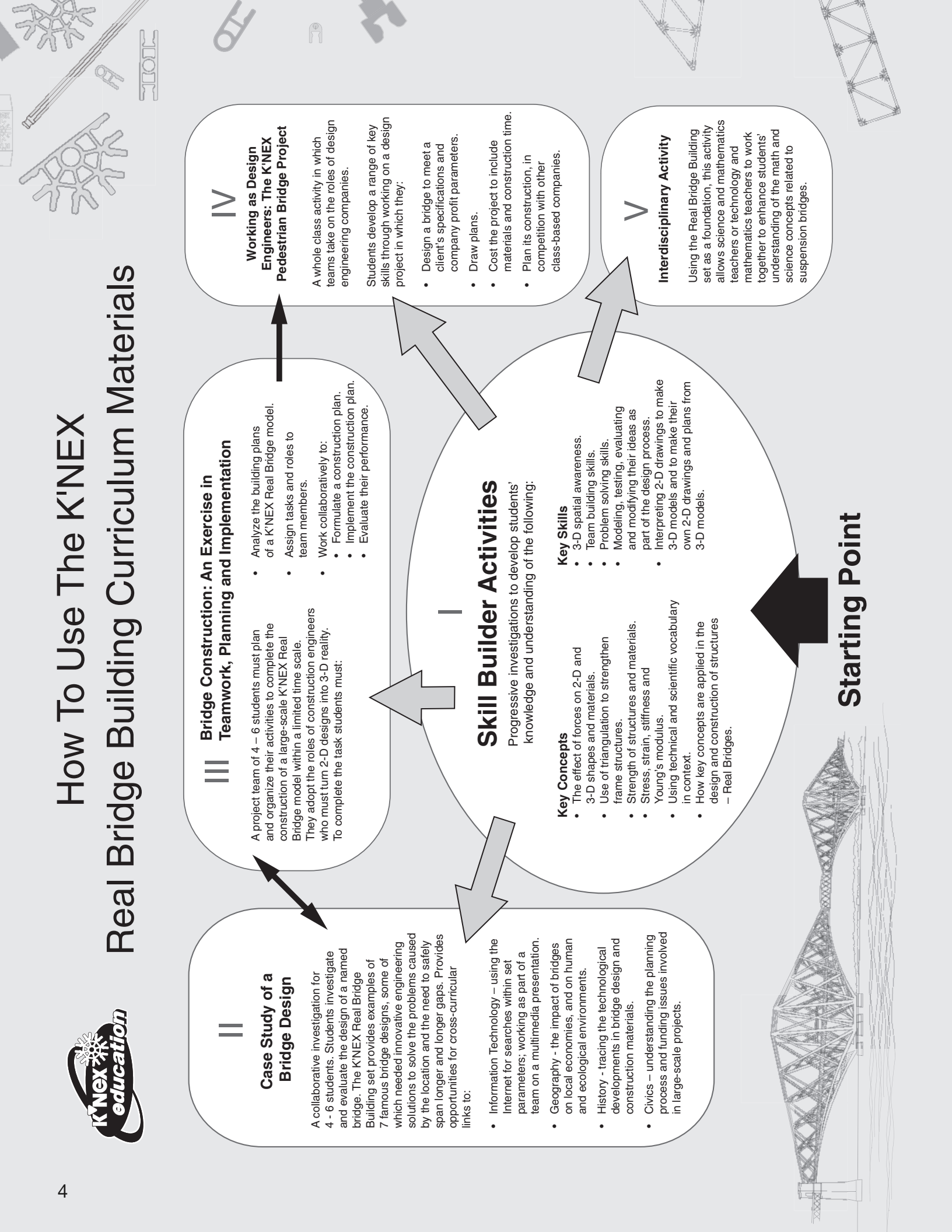
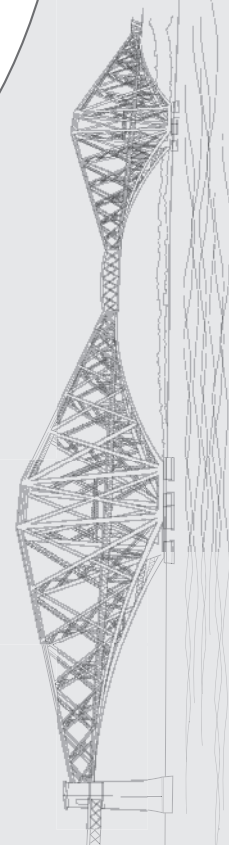

## What is the function of a bridge?

### INTRODUCTION

A bridge is a structure used to cross some form of barrier, making it easier to get from one place to another. From earliest times barriers such as rivers made it difficult for travelers and traders to carry goods by the shortest, quickest and safest route. People on foot, of course, could wade across a shallow stream or use stepping-stones, but these solutions were less suitable for heavily loaded, wheeled vehicles attempting to cross deep, fast flowing rivers. Any historical study of bridges, therefore, demonstrates the ways in which human ingenuity and resourcefulness have been applied to their design and construction in order to improve the movement of people and goods from place to place.

Today, engineers design and build bridges that range in size from superstructures crossing wide estuaries to small pedestrian bridges spanning busy roads, from bridges connecting countries and cultures to those linking different parts of a building, and from structures joining chains of islands to elevated sections of highways linking one part of a transportation system to another. Whatever they carry – motor vehicles, trains, pedestrians, animals, pipelines, or open channels of water – every proposed bridge presents a different set of challenges to the structural engineers who design and construct them.

### DESIGN FACTORS

A bridge's final design will be determined not only by the nature of the barrier to be crossed, but also by the **economic, social, environmental** and **aesthetic** requirements of the communities that it will serve. The original design for the Golden Gate Bridge in California, for example, was a cantilever bridge, with a modified center section lifted by cables.

It was functional because it was designed to open so that ships could pass through and it was also relatively inexpensive to build, yet many thought the design ugly, with one critic asserting that it resembled 'an upside down rat trap.'<sup>1</sup> By the time the funds had been raised to build the bridge, the design had evolved into an aesthetically graceful suspension bridge, linking the city of San Francisco to the Marin Peninsula, while its construction, during the 1930s, led to the rapid growth in prosperity of both the city and the formerly rural region to the north.

### THE BRIDGE BUILDER'S DILEMMA: HOW TO MAKE LONGER AND STRONGER BRIDGES

The earliest bridges were probably fallen trees or stone slabs placed across small streams or gaps – what today would be called a **simple beam bridge**. (Note: the word 'beam' is derived from an Old English<sup>2</sup> word for 'tree'.) This is the simplest form of bridge, constructed from a horizontal **beam** supported at each end by **piers**. A beam may be defined as a horizontal structure that is subject to bending and deflection. A beam supported at only one end, such as is used in a diving board or bookshelf, is called a **cantilever beam**. The piers may be **columns** or **pillars** or some form of natural foundation.



# Reader 1

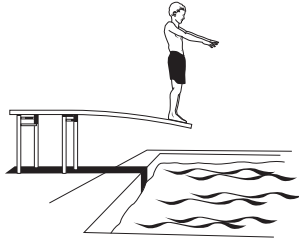

As the need arose to carry heavier loads across wider and wider barriers, the science and technology associated with bridge building developed. People soon discovered that simply making the beam longer did not bring the desired solution to the problem of crossing a wider barrier – long beams tend to bend, or **sag**, in the middle.



Fig. 1: Long beam bending

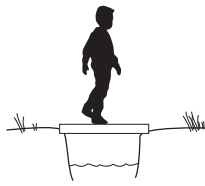

Fig. 2: Short beam remains rigid

Short beams are stronger than long beams of the same thickness, so why not make the beam thicker?

Increasing their thickness or depth can certainly strengthen beams. This action, however, creates yet another problem. By thickening and extending its length, the beam becomes much heavier, more difficult to construct, and more costly to transport into position. A point will also be reached when the beam is so long and heavy that the material from which it is made can no longer support its own weight, causing it to bend even before it has to support a load.

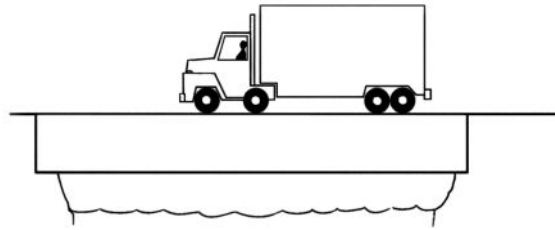

Fig. 3: Strengthening a beam by making it thicker

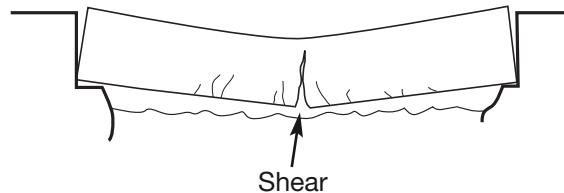

Fig. 4: The bridge itself is too heavy

The problem with the bridge shown in Fig. 4 is that it has been thickened so much that its own weight has become greater than the internal strength of the material from which it is made. Although it looks strong, it is unable to support its own weight and it will **fail** (collapse or fracture) or, at best, it will be very weak.

The weight of all the materials used to make a bridge is called the **dead load** and this must be taken into consideration when calculating the load bearing capacity of the bridge. The weight of all the objects carried on a bridge is called the **live load**. The dead load and live load together provide an estimate of the **working load**.

When the total load capacity is taken into consideration, the longest single **span** for a beam bridge is approximately 80 - 100 meters. A beam bridge, therefore, could not be used in every location and in order to cross wider barriers, new bridge designs were needed.

1. <http://www.pbs.org/wgbh/amex/goldengate/index.html>
2. Old English: Words that have been in use before AD 1150.



## Bridges and Forces 1: The Basics

### DESIGNING A STABLE STRUCTURE

A successful bridge or structure is one that does not collapse, but how can engineers be confident that their design will not have the same disastrous results as the Tay Rail Bridge in Scotland, which collapsed during a storm while a train was crossing it, or the Tacoma Narrows Bridge in the U.S.A. that literally shook itself apart? The answer lies in making sure that the strength of the bridge, including the materials from which it is made, is able to support all the **forces** that may act on it.

From Newton's Third Law of Motion you know that for every action there is an equal and opposite reaction. In other words, if you push against a wall (**action**) it pushes back against you (**reaction**). Nothing moves. The harder you push, the harder the wall pushes back. Still nothing moves. At all times the forces cancel each other out – they are **equal** in strength and **opposite** in direction. Because no movement takes place, the action and reaction forces can be said to be balanced or in **equilibrium**.

If, however, you can push the wall down, the forces are no longer balanced – the action is now greater than the reaction and movement takes place in the direction of the greater force. The result is the wall moves or breaks. Applying this concept to a bridge, if the action (load) is greater than the reaction (the strength of the bridge), movement will take place in the direction of the larger force – the bridge will collapse. (Newton's Second Law of Motion.)

Estimating all the load forces that may act on a bridge is not an exact science. Structural engineers know how to design structures that will successfully support loads and they know the strength of the materials from which it will be made, but it is very difficult to know the size of natural forces that may act against their structure. These they can only estimate.

Look at Fig. 1, which shows a truck crossing a simply supported beam bridge

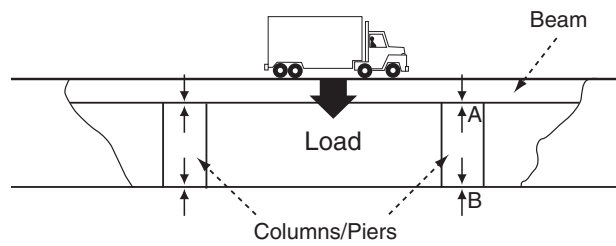

Fig. 1: Action and reaction in the bridge

As the truck crosses it, the bridge does not bend. This is because the resistance from internal forces in the beam balances the weight of the load acting on it – the **reaction** of the beam.

Now consider what is happening to the bridge piers:

- At A, the weight of the beam and load push vertically down on the piers, which in turn push back against them with an equal force – the **reaction** of the piers.
- At B, the total weight of the bridge and load pushes against the foundations of the pier, which in turn push back with an equal and opposite force the **reaction** of the foundations.

Failure will occur, however, if at any place on the structure, the vertical forces pushing down become greater than the ability of the structures to push up. Imagine, for example, what might happen if the ground below one of the pillars could not take the load.

The challenge for the engineer is to design a bridge so that all the forces acting on it are equal and opposite in direction. When this has been achieved, the forces are in equilibrium and the bridge is **structurally stable**.



## WHAT OTHER FORCES ACT ON LARGE STRUCTURES SUCH AS BRIDGES?

Additional considerations that engineers must factor into their design calculations include the **shock load**, which results from a sudden, high impact, such as a train or heavy truck crossing a bridge, and **environmental load**, resulting from the effects of strong winds, rain, ice and snow build-up, river and tidal currents and earthquakes. Some bridges, such as cable-stayed and suspension bridges, are not designed for train traffic because of their susceptibility to shock load, while the Tacoma Narrows Bridge in Washington State collapsed because engineers did not fully take into account the environmental effect on the structure of wind blowing at a constant speed for a long period of time.

## QUESTIONS AN ENGINEER WILL NEED TO ASK

People expect a bridge to be safe at all times, no matter how long it is or what the weather and other environmental conditions are like. Since these are issues confronting all structural engineers, what types of technical information do they require before they begin their calculations? The following are some questions they will need to ask:

- What is the maximum distance that the bridge must span?
- What type of rock will underlie the bridge supports? For example, will the piers or towers be constructed on soft sedimentary rocks or on resistant igneous or metamorphic ones?
- How large a **working load** is the bridge expected to carry?

- What other load factors must they take into consideration? For example, **environmental loading** caused by, among other things, high winds, currents, or snow build-up on the structure.
- What **factor of safety** should they establish so that it takes into account a worst-case scenario? For example, a traffic accident that causes all lanes on a bridge to be filled with stationary traffic, combined with heavy snow and high winds. To account for such an event an engineer might increase the values for loads acting on parts of the structure by 5 times, as a factor of safety.
- How the materials they might use behave when subjected to large **forces** or **stresses**. A material becomes stressed when a force is applied to it and, as a result, may change in length and so become **strained**. (See **Reader 4** for a more detailed discussion of these terms.)

## Bridges and Forces 2: Beams and Columns

### FORCES ACTING ON BEAMS

If you stand on a plank of wood it may bend, but if you jump up and down on it you may find it breaks. This is because jumping up and down produces larger forces than just standing still. Simply standing on the beam creates a **static load** while jumping up and down creates **dynamic loading**.



Fig. 1: Long beam bending

As the name implies, static loads do not move. An example of a static load is the weight of a roof on a building. Dynamic loads, by comparison, move and change and produce much greater forces in structures. The effect of a person jumping up and down may increase the load on the beam by as much as 6 times. Although bridges and other structures may be designed to support mainly static loads, the effects of dynamic loads such as wind and moving traffic must also be taken into account.

External forces acting on parts of a structure, or structural members, are called **stresses**. They include:

- Compression: a force that acts to squeeze a material. Example: stepping on a soda can.
- Tension: a force that acts to stretch a material. Example: pulling a rubber band.

- Torsion: a force that acts to twist a material. Example: wringing out a wet cloth.
- Shear: forces that act in opposite directions against a material. Example: the cutting action of a pair of scissors.



Fig. 2: Compression (squeezing)

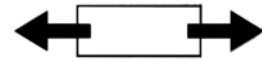

Fig. 3: Tension (stretching)

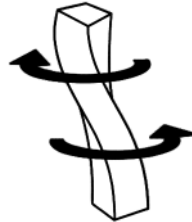

Fig. 4: Torsion (twisting)

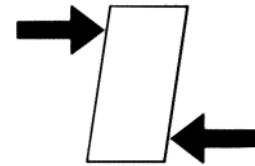

Fig. 5: Shear (sliding)

Stress can cause a decrease in length (**compressive stress**) or an increase in length (**tensile stress**). The result of compressive stress is compression and the result of tensile stress is tension. While compression and tension are the most common forces affecting bridges, torsion and shear can also occur.

When an external force (load) presses down on a beam, compression and tension forces are produced – the top edge of the beam is put under compression, while the bottom edge is put under tension. If the load is large enough, the beam will bend. **Bending is the result of excessive compression and tension in a horizontal beam or column.**



# Reader 3

Subjecting a beam, or any material, to an **external** force causes the **internal** forces that hold the molecules of the material together to react. They resist being pushed apart or squeezed together. As the external forces increase, there is a similar increase in the opposing forces from the molecules being pushed apart or squeezed together.

Think about what happens when you stretch a rubber band. As you stretch it, you can feel a force working in the opposite direction (the reaction, or resistance, of the material). If you remove your stretching force the rubber band will go back to its original size. On the other hand, if you continue to stretch the rubber band it will continue to get longer until a point is reached when it will stretch no further. Continue to increase the stretching force and the band snaps. Its **breaking point** has been reached. The same process is at work in a beam – a point will be reached when the external forces become greater than the ability of the material's internal forces to resist and it will break (**fail**).

The ability of a material to resist being changed in shape is called **stiffness**. Stiffness can be used as a measure of the strength of a material. For example, compare the amount of force that is needed to bend a piece of steel, which has a high stiffness value, with the amount needed to bend a piece of rubber, which has a low stiffness value. Much more force is needed to bend the steel than the rubber and using this measure we would infer that steel is a stronger and more suitable material for building a bridge than is rubber.

*NOTE: Students in upper grade levels may want to explore this concept further in Reader 4.*

You can see compression and tension in action in a **simply supported beam**. A simply supported beam is one that is supported at both ends, as shown in Fig. 6 below. Use a rectangular strip of solid foam rubber with equidistant parallel vertical lines drawn along

one side. Draw a horizontal line equidistant from the top and lower edges.

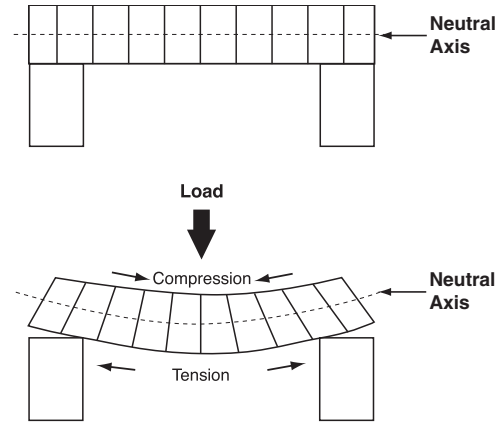

Fig. 6: Using foam rubber to demonstrate compression and tension lines in a beam

Place the foam rubber strip between two blocks of wood or books. Either add a load or push down at the mid-point. As the beam bends the effects of compression and tension can be seen. The lines on the upper edge will move closer together while those on the lower edge will move further apart.

If a single section of the beam is examined in more detail it is possible to see that compression is greatest at the top edge and tension is greatest at the lower edge. At the neutral axis, the beam is neither in compression nor in tension and its length remains the same.

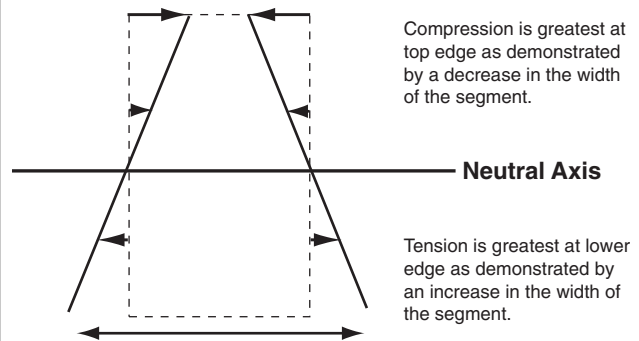

Fig. 7: The effect of bending stresses in a simply supported beam

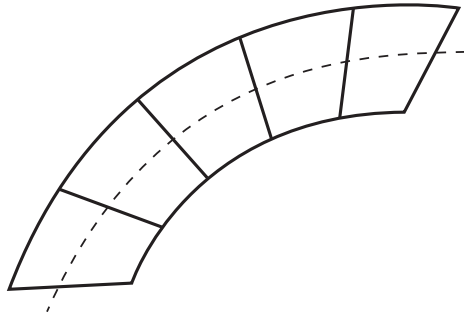

Fig. 8

In a cantilever beam the opposite situation occurs, with tension on the upper edge and compression on the lower edge.

A useful website to visit to explore these concepts further is:  
<http://www.pbs.org/wgbh/buildingbig/bridge/basics.html>

## HOW MIGHT BEAMS FAIL

If the compressive and tensile stresses are too great for the material from which the beam is made, it will fail.

### (a) From bending

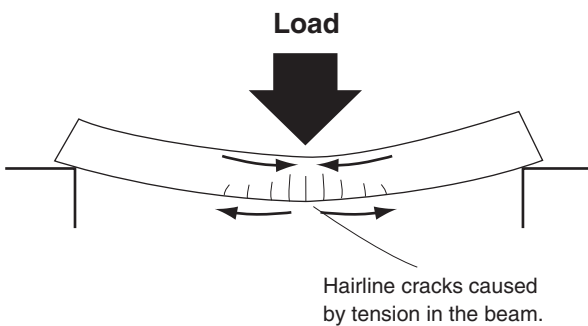

Fig. 9: Thick beam failure

The strength of the material in tension and compression has been exceeded. For example, although concrete is strong under compression, it is weak under tension.

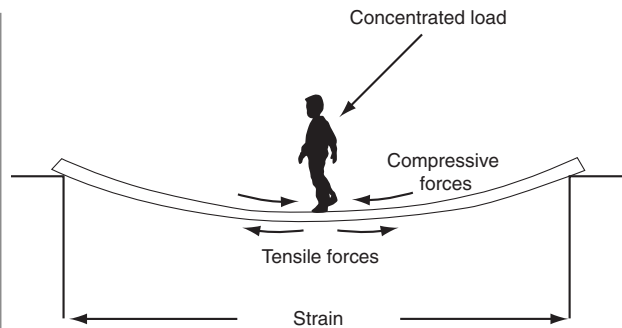

Fig. 10: A long thin beam showing excessive bending

Excessive bending or deflection can occur in long, lightly loaded beams. For example, in long spans using wooden beams.

### (b) From shear forces

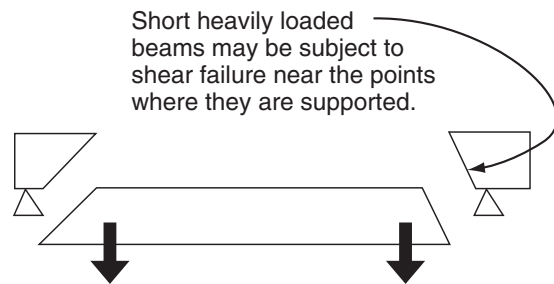

Fig. 11: Failure due to shear forces

## WHAT THICKNESS OF BEAM WILL BE NEEDED TO SPAN A GAP WITHOUT BENDING?

Structural engineers use an equation called the span-to-depth ratio to help them estimate the thickness, or depth, of a beam they might use to span a gap.

$$\text{Span-to-Depth Ratio} = \frac{\text{Length of beam (span)}}{\text{Depth of beam}}$$

How does the ratio help calculate the dimensions of a beam needed to span a barrier?

For a material with a span-to-depth ratio of 25:1, for example, an unsupported beam used to span 25m would have to be 1m in depth. To cover a span of 50m, unsupported, the thickness (depth) of the beam would have to be increased to 2m.

Although it is a simple equation, there is a **limiting ratio** for each type of construction material. This is because the properties of materials (including the ways in which they respond to compression and tension) are different. The span-to-depth ratio for steel, for example, should not exceed 25:1, while the ratio for wood cannot exceed 12:1. This means that steel has a higher span-to-depth ratio than wood so that, for a given depth of bridge beam, a steel bridge can span a longer gap than can a wooden one. There are also limits on the ratio for different designs of beam bridges, so that the ratio used for a simply supported beam will differ from the one used for a cantilever beam.

This web site highlights Pre-Stressed Girder Bridges:

<http://www.cpci.ca/?sc=bs&pn=prestressedgirderbridges>

## Suggested Reading For Upper Grade Levels

### FORCES ACTING ON COLUMNS, PIERS AND WALLS

Columns, pillars, bridge piers and walls are examples of vertical supports designed to take vertical loading.

Vertical loading means that the compression stresses produced by the load act **axially** along the length of a column. Both compression and tension are the result of **axial forces** acting on a structural member.

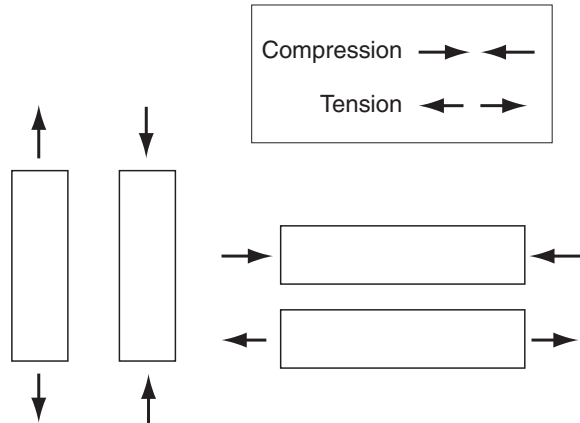

Fig. 12: Axial forces acting vertically and horizontally on columns

How a column behaves depends on the strength and stiffness of the material it is made from and its slenderness ratio. The **slenderness ratio** is the ratio of the height of the column to its width.

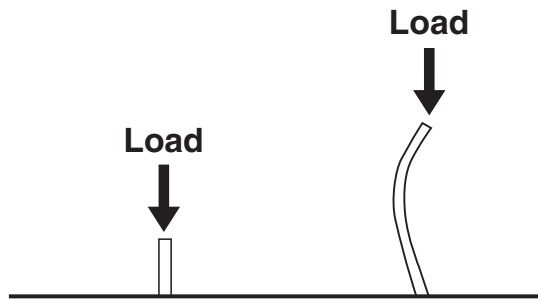

Fig. 13: Height and the slenderness ratio

Increasing the height of the column increases the slenderness ratio but the load bearing capability of the column decreases. For example, a short piece of dowelling will not bend under a large load but a long piece bends easily. Generally a short, wide column can support a greater load than a long, slender one.

Columns can fail under compression by **crushing (A)**, **buckling (B)**, or **kneeling (C)**.

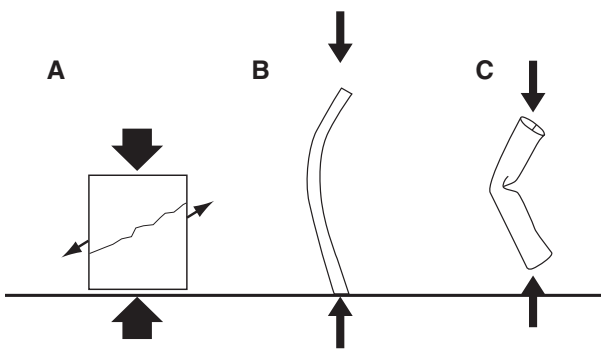

Fig. 14: Column size and the effects of compression

### A: Short, wide columns

The main factor here is the strength limit of the material. **Brittle** materials such as concrete may crumble and break, while softer materials such as those used to make a soda can, will crush without first buckling or bending.

### B: Long, slender columns

These tend to **buckle** before the deformation becomes permanent. If the force is released before permanent buckling occurs, the column will return to its original shape, as could happen with long bamboo canes.

### C: Intermediate length column

**Kneeling** will occur when some areas give way before buckling occurs, as may occur in a tubular steel chair leg.

The slenderness ratio for pre-stressed concrete is about 10:1 which means a 10m tall column of pre-stressed concrete would have to be 1m in diameter and for every 1m increase in height, the diameter of the column must increase by 10cm.

How do structural engineers use this ratio to compare materials?

The slenderness ratio value for steel is 40:1, while that for pre-stressed concrete is 10:1. This means that a 10cm diameter column of steel can support the same compressive forces (load) as a 40cm diameter column of concrete. Columns will also bend first in the weakest direction, so a square column with its symmetrical dimensions will be stronger than a rectangular one with asymmetrical dimensions. Considerations such as these must always be factored into the calculations made by engineers as they develop their design for a structure.



# Stress, Strain, Stiffness and Young's Modulus

## Suggested Reading For Upper Grade Levels Only

### PROPERTIES OF MATERIALS USED IN MAKING BRIDGES AND OTHER LARGE STRUCTURES

It is important for structural engineers to know and understand how the materials they plan to use behave when subjected to any type of force. From previous Readers you will know that when forces are applied to a material, it will become **stressed**. As a result of **stress**, the material may change in length. When the length of a material has been changed it has become **strained**. **Compressive stress** produces a shortening in length while **tensile stress** causes an increase in length. The result will be compression or tension in the material. Some materials are strong under compression – wood, reinforced concrete, steel, stone, bricks and some plastics; other materials are only strong under tension – rope, string, paper, steel cables and wood (when cut along the grain).

You might assume that small loads will have little effect on the massive steel girders that make up a bridge, or the bricks in the wall of a house. In fact, all structures and materials are deformed to some extent when loaded. Some changes are so small they cannot be seen unless measured using very accurate equipment; others are more obvious. When you squeeze a sponge, stretch a rubber band or walk across a plank, for example, the effects can be clearly seen. The effects of the weight of people on a steel girder in a building or on the legs of the chair, however, are not usually visible to the naked eye and yet they do

produce extremely small, measurable, changes in the structure.

Structural engineers must also design bridges that are not only able to resist deformation by large stresses but which are also flexible and able to change. Changes of temperature, for example, will cause bridge materials to expand and contract, while bridges built in areas subject to seismic activity should be able to flex in response to earth movements.

### STRESS

It is much easier to pull and break a thin thread than a thick rope, or to walk across deep snow using snowshoes than without them. A person wearing snowshoes will spread the load over a much larger area, reducing the stress on the snow and as a result he or she will not sink into the snow very far. Without snowshoes the stress on the snow is high and the person sinks much deeper. This demonstrates the concept of **point load** versus **distributed load**.

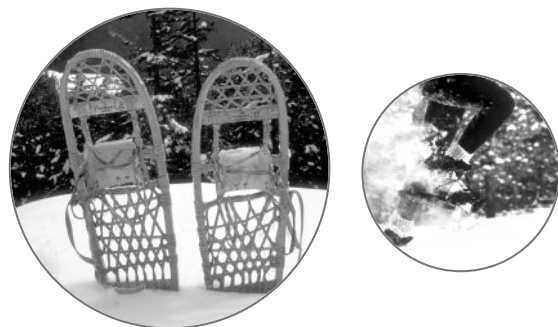

These examples also highlight two key points about stress. The amount of stress to which a material is subjected, whether it be thin thread,



snow, a plank of wood, a brick, or a steel girder, depends on (i) the size of the force (F) and (ii) the area (A) over which it is applied.

$$\text{Stress} = \frac{\text{Force (Newtons)}}{\text{Area (m}^2\text{)}}$$

- A force applied over a small area produces high stress.
- A force applied over a large area produces low stress.

Consider, for example, the foundations of a bridge column:

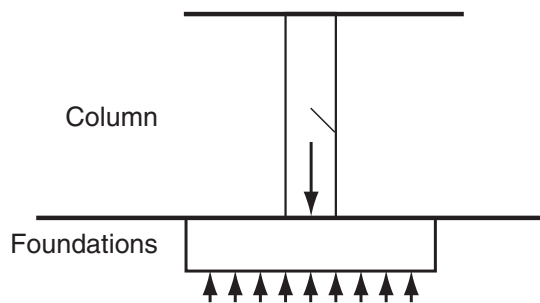

Fig. 1: The small area immediately below the column base will be subject to high stress levels whereas the much larger area of the foundations will be subjected to low stress.

If the concrete column in Fig. 1 has a cross-sectional area of 0.1m<sup>2</sup> and is being compressed by a load of 100,000N the stress on the column can be calculated as follows:

$$\begin{aligned} \text{Stress} &= \frac{\text{Force (Newtons)}}{\text{Area (m}^2\text{)}} \\ &= \frac{100,000\text{N}}{0.1\text{m}^2} = 1\text{MN/m}^2 \end{aligned}$$

(NOTE: 1MN = 1Meganewton = 1,000,000N;  
1MN/m<sup>2</sup> = 146 psi)

Stress values for different materials vary widely. Some examples are given in Fig. 2. Note: the higher the value, the greater the resistance of the material to external forces.

Fig. 2: Examples of stress values for common materials

Material	Stress value MN/m <sup>2</sup>
Steel	400 - 1000
Cast iron	150
Wood	100
Aluminum	70

## STRAIN

Strain is a measure of the change in length caused by stress. Values for strain are obtained by putting a material under tension and measuring the change in length produced by a load. The change in length is then compared to the original length.

$$\text{Strain} = \frac{\text{Change in length}}{\text{Original length}}$$

For example: Ropes and steel cables stretch when used to lift heavy loads. When lifting the same load, a 5m rope may increase in length by 0.04m, whereas a steel cable, with the same diameter and lifting the same load, may increase in length by only 0.0006m.

The strain values:

### Rope

$$\text{Strain} = \frac{\text{Change in length}}{\text{Original length}} = \frac{0.04\text{m}}{5\text{m}} = 0.0080 \text{ or } 0.80\%$$

### Steel cable

$$\text{Strain} = \frac{\text{Change in length}}{\text{Original length}} = \frac{0.0006\text{m}}{5\text{m}} = 0.00012 \text{ or } 0.012\%$$



# Reader 4

Strain values are often expressed as percentages. The much lower value for the steel cable tells us that steel is a stronger material than rope because it showed a greater resistance to its length being changed.

When designing structures it is very important to know how stress affects the length of a material. A graph of stress against strain provides additional information.

Fig. 3: Graph of stress against strain

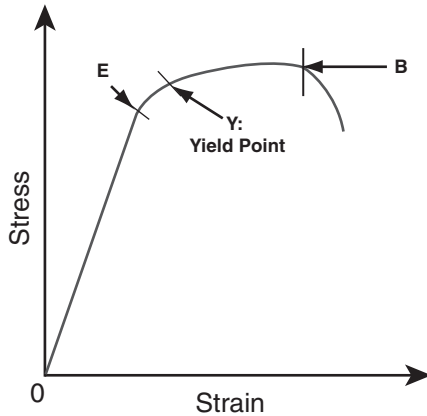

**O-E:** In the straight part of the graph, the change in length is proportional to the applied load (Hooke's Law). In this part of the graph, materials usually return to their original shape once the load is removed. Materials that behave in this way are said to be *elastic*.

### E: Elastic Limit

Beyond this point the material cannot return to its original length and will be permanently deformed.

### Y: Yield Point

The material has been permanently strained.

### B: Breaking Point

If the stress increases beyond this point the material breaks.

## WHAT DO STRESS-STRAIN CURVES TELL US?

The steepness of the slope is the key. This graph (Fig. 3) has a steep slope, which indicates that a very large stress, or load, is needed to produce a small change in length (strain). Steep slopes are typical of **strong** and **stiff** materials such as metals.

From the origin (O) to point E, the material obeys *Hooke's Law*. In other words, the extension of the material is directly proportional to the load. (The strain is proportional to the stress).

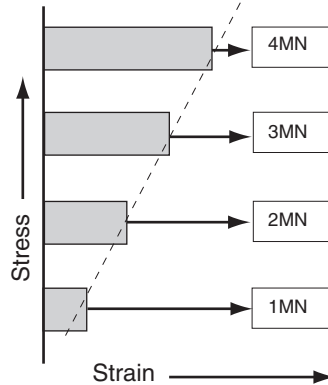

Fig. 4: The gray areas show the increase in length (strain) caused by the values of the tensile stress in the boxes. As the tensile stress increases, so the increase in length increases so that the dotted line joining all the bars is a straight line. In other words, the increase is proportional to the stress.

Many materials are elastic, provided they are not stressed beyond point E (the **elastic limit**). This means that when the stress is removed, the material will return to its original length – just like a rubber band.

If the material is stressed beyond the elastic limit, a point is reached at Y (**yield point**) when a marked increase in length can occur, and even when the stress is removed, the material will not return to its original length. The material has been permanently strained, as shown in Fig. 5 on Page 17.

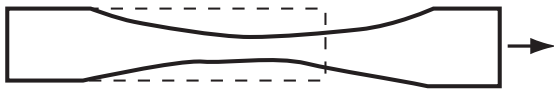

Fig. 5: This material has been stretched beyond its elastic limit (dotted line) and is permanently strained.

If the stress is continued, the material will eventually break. Point B on the graph shown in Fig. 3 represents the material's **breaking stress** point.

Different materials produce different stress-strain graphs.

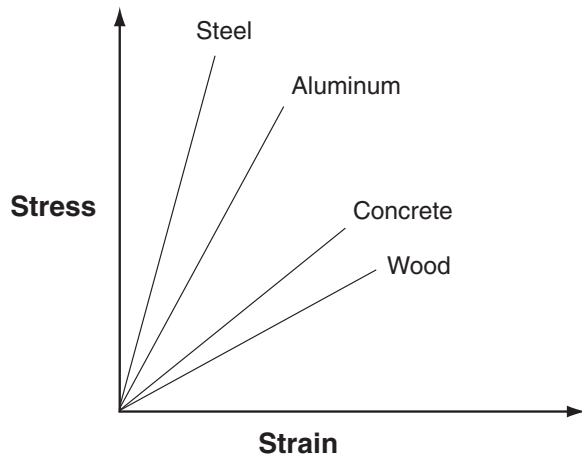

Fig. 6: Stress-strain graphs

The steeper the slope of the stress-strain graph, the stronger and stiffer the material. Some materials, such as bricks and concrete, have a steep slope but break before they reach their elastic limit. They are very difficult to stretch and they snap easily. Such materials are said to be **brittle**. On the other hand, a **ductile** material is one that can be stretched without sudden failure, for example metals such as steel.

## YOUNG'S MODULUS

By comparing the slopes of the straight-line parts of the stress-strain graphs, it is possible to compare the relative stiffness of different materials. The measure of the stiffness of a given material is known as **Young's modulus** or the **modulus of elasticity**.

The symbol used to represent Young's modulus is **E** and can be simply calculated as:

$$\text{Young's Modulus} = \frac{\text{Stress}}{\text{Strain}}$$

Example:

A sample of mild steel produced a strain of 0.002 when subjected to a stress of 420MN/m<sup>2</sup>.

$$\text{Young's Modulus (E)} = \frac{\text{Stress}}{\text{Strain}} = \frac{420\text{MN/m}^2}{0.002} = 210,000 \text{ MN/m}^2$$

When designing structures, engineers use Young's modulus to help choose the right material for a particular structure. (See Fig. 7 below.)

Fig. 7: Young's modulus values for some common materials used in structures.

Material	E MN/m <sup>2</sup>
Steel	190 - 210,000
Wrought iron	190,000
Cast iron	83 - 170,000
Titanium	110,000
Aluminum Alloy	70 - 79,000
Granite	40 - 70,000
Concrete	17 - 31,000
Softwoods	11 - 14,000



# Making Strong Structures

One of the many factors that structural engineers must consider when undertaking a project, is **cost**. Thickening a cable or beam, (increasing its cross sectional area,) may allow that part of the structure to support a much greater load before it reaches its breaking point, but doing this may also increase both the weight and **cost** of the structure. Engineers, therefore, must find ways of making structures lighter while using less material, or using materials in different ways to make them strong. Their goal is to use the minimum amount of material possible to keep down costs and still meet strict safety standards.

Some materials are strong under **compression** – wood, reinforced concrete, steel, and some plastics, for example; others are strong under **tension** - rope, string, paper, and wood – when cut along the grain. By combining materials it is often possible to get the benefits of both. Many bridges, for example, are constructed from reinforced concrete. Concrete, a cheap material, is strong under compression but weak under tension. Steel is strong under both conditions, but it is expensive to produce. Long steel bars are not rigid, but may bend under their own weight. Reinforced concrete has steel bars running along its length and so is strong under both tension and compression. This makes it a good choice for many types of structures because it is relatively cheap to produce, is rigid, and is strong under tension and compression.

Experimenting with the properties of reinforced concrete is not usually possible in the classroom, but testing the properties of paper, cardboard, wood, drinking straws or even spaghetti, under different conditions, demonstrates how materials can be modified to make them suitable for use in structures.

- Can paper be used to make structures? What are its strengths and weaknesses?



Fig. 1a

Paper Forces

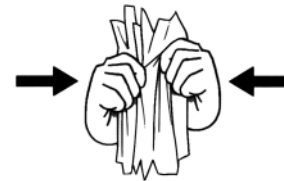

Fig. 1b

This test demonstrates how paper is strong under tension but weak under compression.

- Is it possible to change the structural properties of materials?



Fig. 2: Limp paper

When held between your hands, a sheet of copy paper flops down – it is not very rigid. When folded, however, it has different properties.

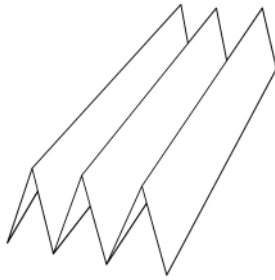

Fig. 3: Making paper rigid

The sheet of paper is now rigid and can support some surprisingly heavy loads. Try testing its load bearing capacity.



Fig. 4a



Fig. 4b



Fig. 4c

Paper columns

Rolling a sheet of 8.5" x 11" (or A4) paper to make a tube produces a structure that is surprisingly strong. Try to compress (squeeze) it along its length (**axially**). You may want to discover what type of load the tube of paper can carry before buckling (failing). Paper composites are actually used to make parts of passenger aircraft because they are strong but very light.

- **What types of load can the tube of paper carry before buckling (failing)?**

Tubes, even paper ones, are strong under compression and tension, but not strong in resisting bending forces (see Fig. 4c).

Paper tubes, used in the right way, however, can make quite strong structures. Similarly, hollow steel tubes are often used in structures to provide strength, while keeping the amount of steel used, and hence costs, to a minimum.

The ability of a tube or column to support a load depends on a number of things including the shape of its cross-sectional area and its length. For example, a short, wide tube will be able to support larger loads than a long, thin one; a square column will support a larger load than a narrow rectangular one of the same cross-sectional area.

By changing its shape, we can make what at first appears an inappropriate material into one that can be used to make strong structures.

Balsa wood and spaghetti do not come to mind as strong bridge building materials, but used in the right way, quite strong bridge structures, able to support many times their own weight, can be made from these materials.

## SHAPES USED IN STRUCTURES

4 shapes are commonly used in structures: **squares, rectangles, triangles and arches.**

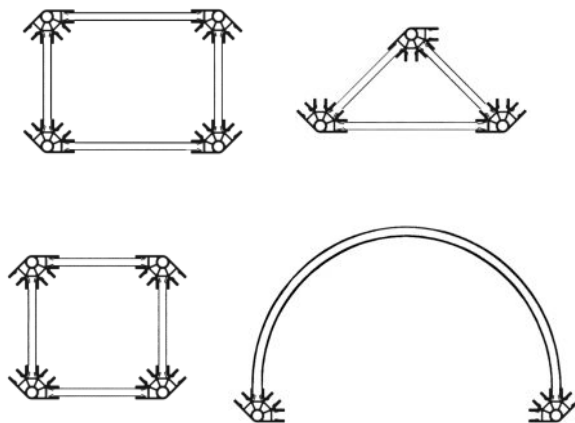

Fig. 5: Shapes commonly used in structures



# Reader 5

- What happens to these shapes when forces are applied to them?

## RECTANGLES

When a rectangle or square is squeezed from corner to corner, their shapes are changed. They now become parallelograms and therefore, on their own they are unstable shapes to use in structures.

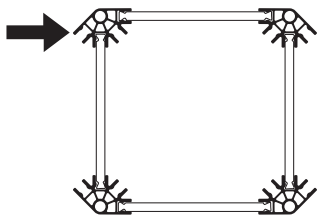

Fig. 6

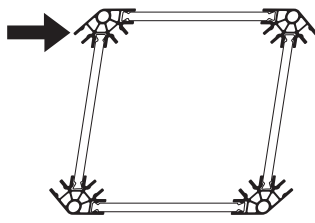

Fig. 7

Fig. 6 & 7: Pushing at a corner - using K'NEX models.

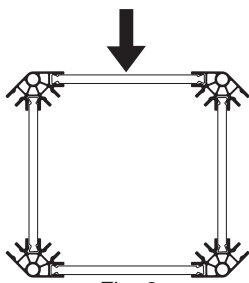

Fig. 8

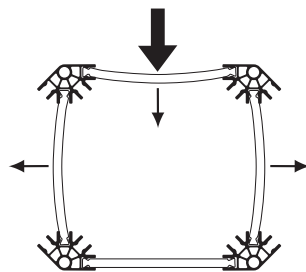

Fig. 9

Fig. 8 & 9: Loading the top - using K'NEX models

The force or load causes both the top and the sides to bend, with the sides bending outwards.

## STRENGTHENING A SQUARE - TRIANGULATION

Materials such as wood, concrete and steel are strong under compression. In the activities described below K'NEX Rods behave as if they are strong materials. By adding a **diagonal brace** to a square so that the forces act axially (along its length), the square can be strengthened and reinforced. It is now a rigid, stable structure.

**A brace is a strengthening or reinforcing component of a structure.**

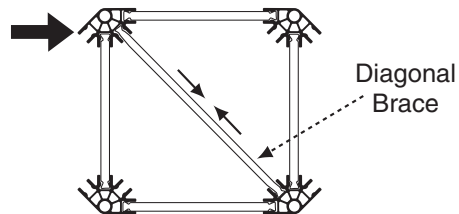

Fig. 10: Strengthening triangles

By creating triangles (triangulation), square can be strengthened and reinforced so that they do not change shape when forces are applied to their corners. Braces that resist compression are called **struts** and those that resist tension are called **ties**.

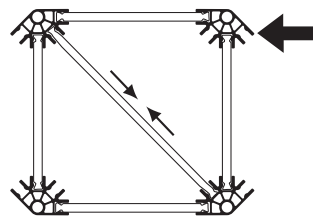

Fig. 11: Tension acting on the tie

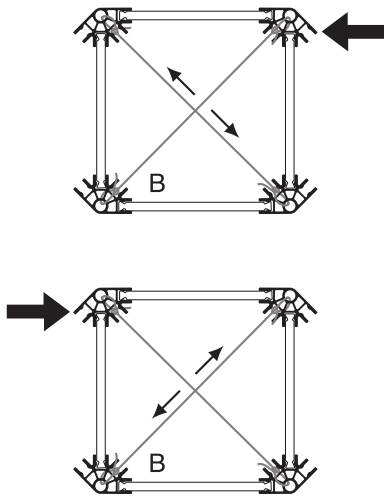

Fig. 12: Using string to create a stable rectangular structure

A single, rigid brace on a square can be replaced by two non-rigid cables or ropes. Tightly tie string to the corners of your square as shown above. If you use your hands to place a force on the shape as shown by the dark arrows on the drawing one of the strings will resist the force thus strengthening the square. If you use your hands to place a force on the shape (in direction of big arrows) the other string will resist the force thus strengthening the square. In a real-world application of this principle, steel cables are used in place of the string in your model. They can strengthen both square and rectangular components of structures.

## TRIANGLES

If a load or force is applied to one of the sides of a triangle, the side may bend inwards. The side is the weakest point in a triangular structure.

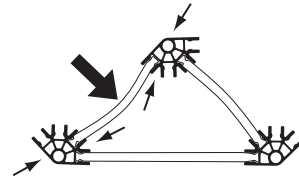
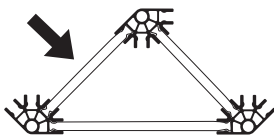

Fig. 13: Forces applied to the sides of triangles

If, however, a load or force is applied at one of the angles, the triangle does not bend because the two sides are squeezed and the base is stretched. The forces acting on the triangle are distributed around the whole structure, not just on one side.

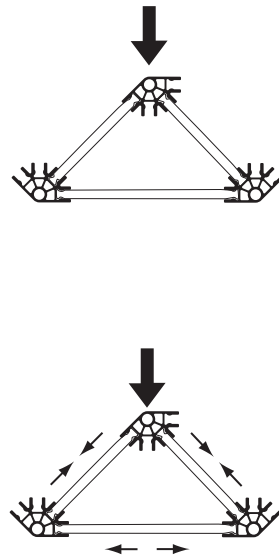

Fig. 14: Force applied at the angle of a triangle

Used in the right way, triangles are the most stable and rigid shapes that can be incorporated into the design of a structure.

When designing structures, engineers try to eliminate any bending forces acting on structural members as this can produce weaknesses; instead they attempt to exploit the strength of materials when under either compression or tension.

## ARCHES

Arches have been used in structures for thousands of years. Many arched bridges and aqueducts built by the Romans are still in use today – a testimony to their strength.



When a load is applied to the top of an arch, the top moves down, while the sides tend to move outwards. In other words, compressive forces applied to the top of the arch produce thrust at the base.

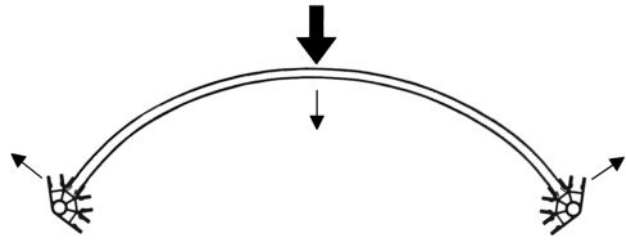
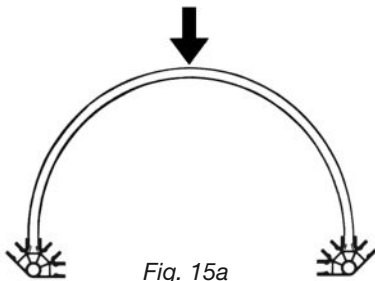
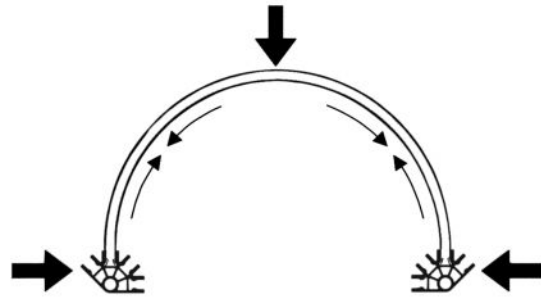

Fig. 15a and Fig. 15b: Forces acting on an arch

If, however, the sides are buttressed by external supports, these will push back with a reactive force and stop the sideways thrust. With the addition of these external supports – called **abutments** – all the forces will be acting to compress/squeeze the whole arch together. This results in a very strong structure.



Arches, however, do have their limitations. If the arch span is too large in relation to its height, the structure is weakened because much larger reaction forces from the abutments are needed to balance the sideways thrust of the arch.

Engineers are concerned with the ratio of the arch span and the height (or rise) of the arch – the **span-to-rise ratio**. In general, the span-to-rise ratio for steel arches is in the region of 30:1, which means for every 1m rise there can be a 30m increase in the span.



Modern arch bridges, such as the Sydney Harbour Bridge, are made from steel frames because steel allows the construction of longer arch bridges than those made from stone. The largest single span arches today are approximately 250 meters wide.



## Different types of bridges

If you have ever looked at bridges while traveling in your local area, or on trips to more distant places, you may have identified many different designs. The Chesapeake Bay Bridge, for example, looks very different from the Golden Gate Bridge, and while the Golden Gate has some similarities to the Dames Point Bridge, it bears no resemblance to the Astoria Bridge. Or does it? In fact most bridges have developed from just two basic designs – the beam and the arch.

### BEAM BRIDGES



- **Construction and materials**

The beam bridge supports its own weight and its load on upright, or vertical, piers. It is typically used to span narrow distances over small streams or rivers, or over highways. While wood and stone were commonly used for this type of bridge construction in the past, modern beam bridges are usually constructed from steel and reinforced concrete.

- **Forces acting on the bridge**

The forces acting on a beam bridge tend to compress the top but stretch (place under tension) the bottom of the beam. The piers supporting the weight of the bridge are under compression.

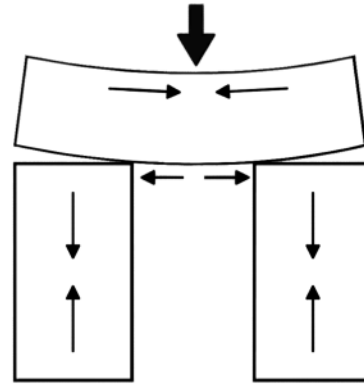
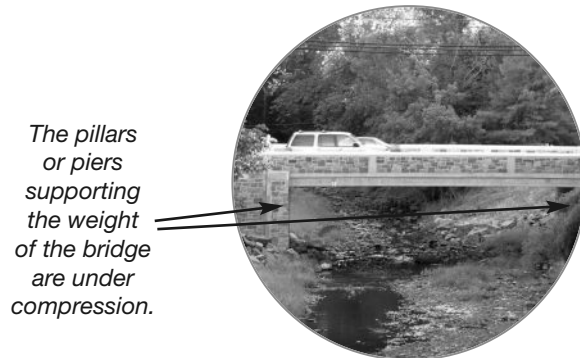

Fig. 1: Forces in a beam bridge



The pillars or piers supporting the weight of the bridge are under compression.

Long beams are much weaker than short beams of the same thickness.

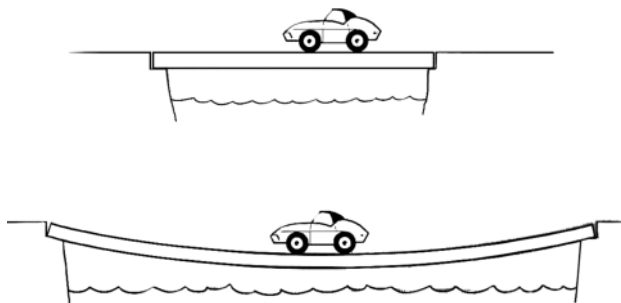
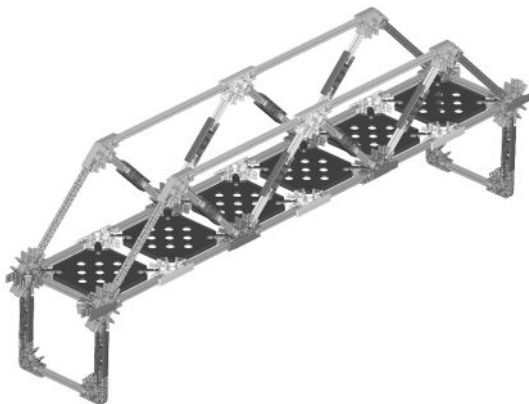

Fig. 2: Long beams are weaker than short ones

Increasing the thickness of the beam can make this type of bridge stronger and more rigid. This, however, not only increases the cost, but can also make the bridge much heavier. A point will eventually be reached when the bridge cannot support its own weight and it will fail. (See Fig.4 in Reader 1.) There are, therefore, only a limited number of sites where a simply supported beam bridge can be used successfully.

## TRUSS BRIDGES



### • Construction and materials

A truss bridge is a type of beam bridge in which the beam is constructed from a lattice of straight sections, usually made from steel, that are joined together to form a series of triangles (triangulation). Constructing a beam using triangles offers three advantages:

- (i) the beam can be thicker
- (ii) the weight of the beam is not significantly increased
- (iii) the technique creates a strong, rigid structure.

Early truss bridges included just a few triangles and were made from wood (see Fig. 3 & Fig. 4).



Fig. 3: King Post truss design

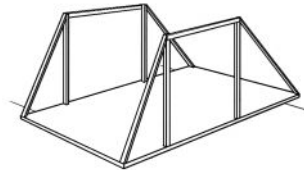
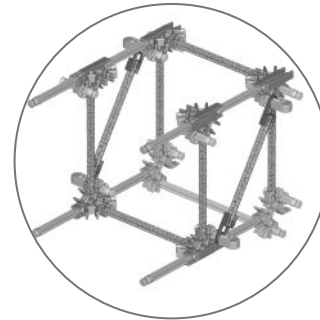

Fig. 4: Queen Post truss design



As better materials, such as wrought iron and steel, became available, trusses became more complex, incorporating larger and larger numbers of triangles in their designs. In some cases the beam is “bow shaped,” thicker in the middle to provide greater strength where a simple beam would bend the most, and thinner at either end, where it bends least.



# Reader 6

Reader 6

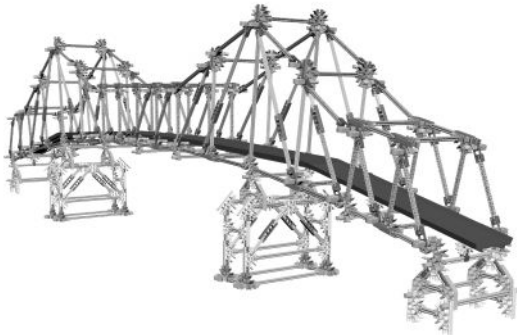

While the addition of trusses can increase the strength of a beam, truss bridges also have limits on their maximum practical length. The longest steel truss girder bridges are around 500m long.

## LONGER BRIDGES

A long, simply supported beam bridge will bend in the middle when loaded. Engineers have attempted to overcome this problem in two ways. They have designed bridges so that the weak point in the structure (where it bends) is either pushed up from below by a pier or pulled up from above by cables or some other method. These two techniques have resulted in a variety of bridge designs, capable of spanning longer distances, but still based on the beam.

A different approach to spanning wider barriers, one that has been in use for more than 2000 years, is to use an arch structure. What follows is a brief overview of the design options available to engineers taking on a new bridge building project.



Fig. 5a: Problem: The bridge bends and is weak

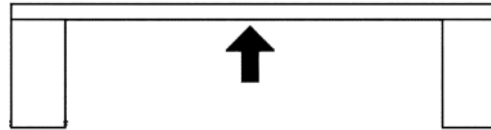

Fig. 5b: Solution 1: Push up from below

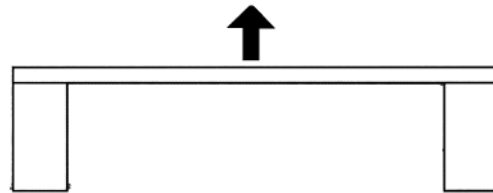

Fig. 5c: Solution 2: Pull up from above

## Available Options

### 1. Using multiple spans and supporting piers CONTINUOUS SPAN BRIDGES



Photo Courtesy of the Chesapeake Bay Bridge-Tunnel

Instead of using a long, single span that is likely to bend in the middle, engineers can build bridges using many small beams that are joined together. The Chesapeake Bay Bridge-Tunnel in the U.S.A. is constructed in this way and is known as a **continuous span** bridge. The bridge, (and tunnel), extends across the shallow Chesapeake Bay, for about 26 kilometers, but the longest single span is only 30 meters.

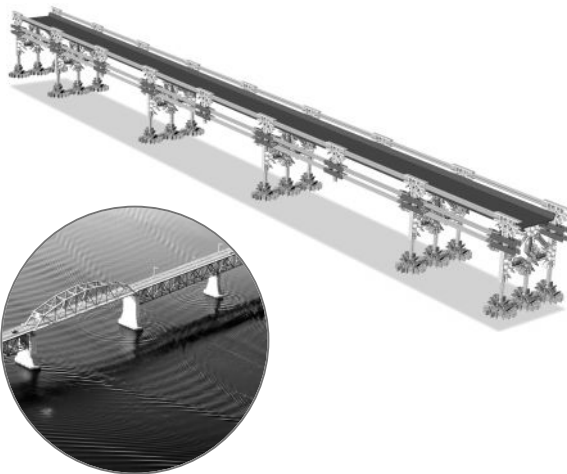

## 2. Using Cantilevers

### CANTILEVERS BRIDGES

A cantilever bridge is another variation of a beam bridge. In this type of bridge there are usually two beams, extending out from opposite sides of a barrier. Each cantilever beam is supported by one pier only. Often an additional beam is suspended on the two beams to form an even longer span.

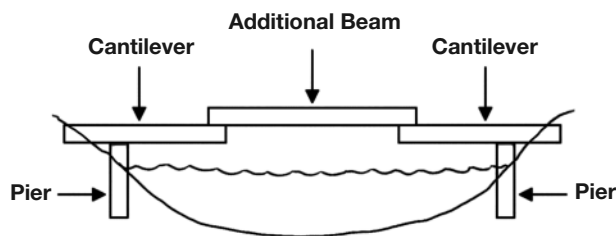

Fig. 6

Each pier is firmly embedded in bedrock and the deck extends out on either side of the supporting pier. Imagine yourself standing with both arms held out horizontally – your arms are acting as cantilevers. The weight of a cantilever bridge system is supported by its piers, which in turn must be supported by the bridge foundations and the bedrock.

In the cantilever system, the weight of the deck (and/or the anchors/counterweights) on the landward side of the pier balances the weight of the deck extending over the gap. A good analogy to help you think about this is a seesaw – if you make one arm of a seesaw longer you must then increase the length of the other arm by the same amount to keep it balanced, or you must add weight to the shorter arm.

Keeping the forces balanced allows the beam to extend far over the gap with a minimal amount of additional support. The beam can be balanced either by:

1. Extending each span outwards, away from the pier to make a T-shaped structure – like a giant seesaw.
2. Adding counterweights, or anchors, at the ends of the cantilevers, where they meet the shore – like a parking lot barrier. The anchors serve as weights at one end of the system, so the part of the beam extending beyond the pier, over the gap, can be made longer.

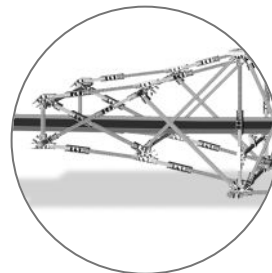

## Cantilevers in Action

To see cantilevers in action you will need 5 books of an equal size (or wood blocks). Stand two books vertically – these represent the supporting piers. Lay a book, horizontally, on each of the piers – these represent the cantilevers. Each pier and cantilever should look like a letter T. Now connect the two cantilevers by balancing another book across the gap or by moving the two cantilevers together so that they meet. It may be necessary to counterbalance the horizontal beams when a load is applied to one end.

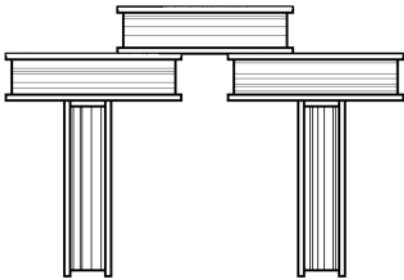

Fig. 7

Adding struts below the cantilever will provide additional support. The struts are joined to the bridge's piers and are subject to compression. If, however, the struts are long and thin they might bend and buckle and so additional support could be needed.

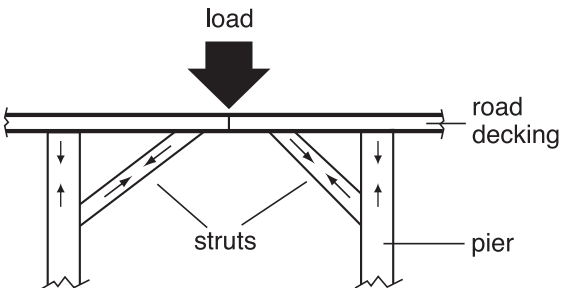

Fig. 8

Even more strength could be added by pulling the beam upwards at the same time. The supports above the beam are subject to tension and help balance the compression forces acting on the lower supporting struts.

This is the basis of the design for the Forth Rail Bridge. (See diagrams/photographs below.)

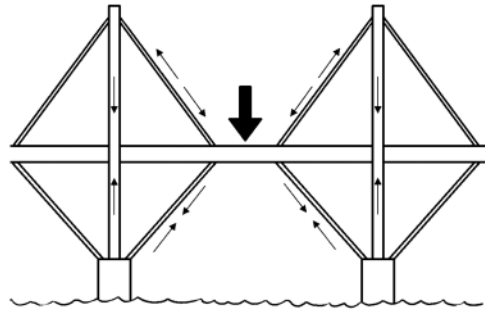

Fig. 9



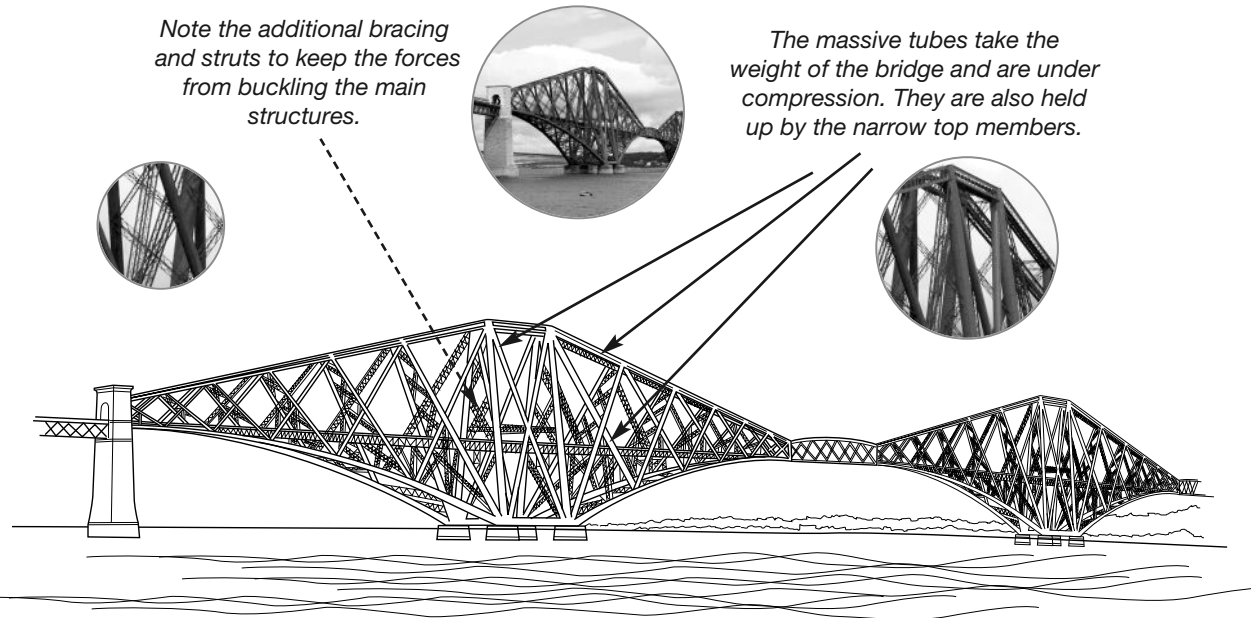

Fig. 10

The Forth Rail Bridge, crossing the wide estuary of the Firth of Forth near Edinburgh, Scotland is one of the world's largest cantilever bridges. It was constructed of steel in 1890 and has a length of approximately 2500 meters. Its central span between the two cantilevers, however, is only 100 meters wide.

In this example the rail decking is supported from below by struts and from above by ties. Additional support is provided by a latticework of triangles above and below.



*Jacques-Cartier Bridge, Montreal, Canada: a cantilever bridge that incorporates a supporting steel truss structure.*

Like the Forth Rail Bridge, many cantilever structures have a triangular shape. These include roofs for train and bus stations, sports stadiums, some carports and even bookshelves.



## 3. Using cables to pull up from above

### A. SUSPENSION BRIDGES

The use of suspension bridges quite possibly dates back to pre-history – vines in forested areas may have been used to construct footbridges across narrow valleys. Today, suspension bridges form some of the longest bridges in the world.



- **Constructions and Materials**

Modern suspension bridges use steel cables strung between two towers, which support the weight of the bridge. The cables pass over the tops of the towers and their ends are anchored in the bedrock. The decking is suspended from vertical cables, called suspenders (or hangers), which hang down from the main cables. The road decking itself may be gently arched, with a truss structure to provide additional strength and rigidity.

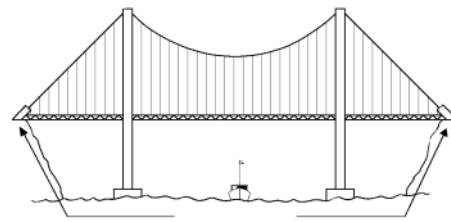
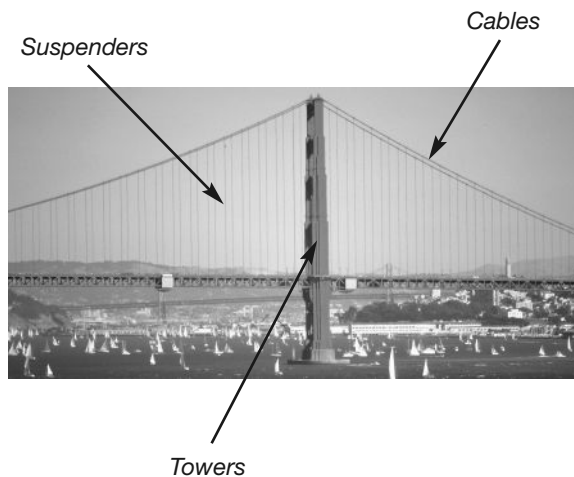

Anchorages

Fig. 11

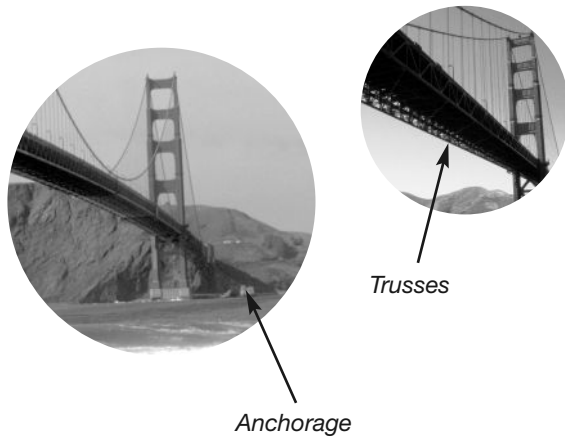



- **Forces acting on the bridge**

The design of suspension bridges, like any other type of bridge, must ensure that the forces acting on the structure are balanced and are working together in harmony. With a suspension bridge, the cables and suspenders are under tension as they are always being stretched, while the towers are under compression because the cables and the weight of the road decking push down on them.

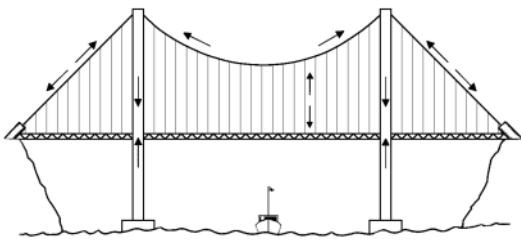

Fig. 12: Forces acting on a suspension bridge



The Humber Bridge: Total length - 2220 meters

The very longest bridges built today are suspension bridges, capable of spanning lengths of 4000 meters. The Akashi Bridge, linking the Japanese islands of Shikoku and Honshu, for example, has a length of 3,911 meters.

## B. CABLE-STAYED BRIDGES

Cable-stayed bridges include design elements from both cantilever and suspension bridges: the road decking of the bridge is the cantilever structure, suspended by cables from a tower. Each tower supports a balanced portion of the deck by way of its cables. While the design idea is not new, this type of bridge became increasingly popular from the mid-20th Century onwards, largely due to developments in construction materials (pre-stressed concrete).

They are also relatively inexpensive to build because, unlike a tower-to-tower suspension bridge, they do not require anchorages. As a result, a cable-stayed design is often selected for locations where, in the past, a medium sized (under 1000 meters) suspension bridge would have been built. It is also worth noting that advances in technology have resulted in the construction of cable-stayed bridges with lengths over 2500 meters.



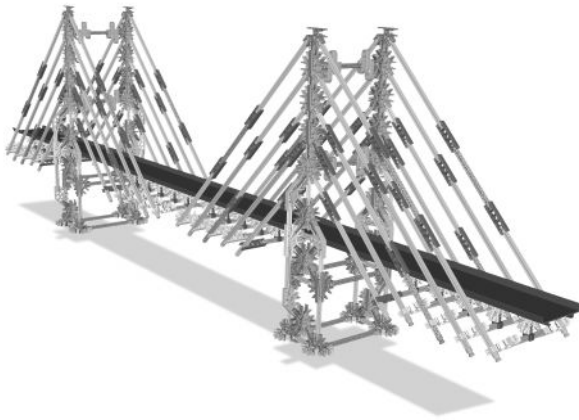

- **Construction and Materials**

Cables, attached to a tall tower, are used to support the bridge road decking. The cables run directly from the tower to the deck. Towers are typically constructed from concrete or steel, while the cables exhibit great variety in their design. (See Fig. 14.)

- **Forces acting on the bridge**

All the cables are under tension and the tower, which is under compression, supports the total weight of the bridge and everything on it.

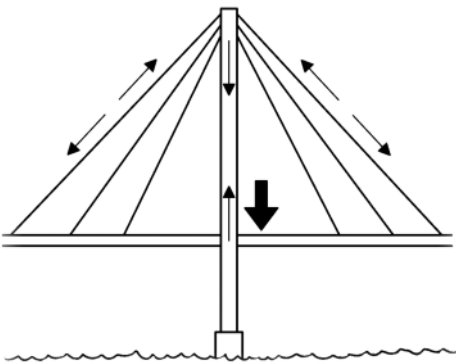

Fig 13: Forces acting on a cable-stayed bridge

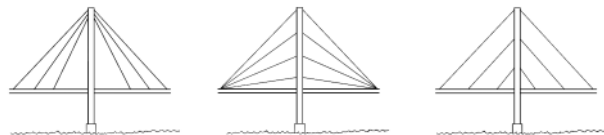

Fig. 14: Cable designs

*NOTE: We encourage you to visit [www.brantacan.co.uk/cable\\_stayed.htm](http://www.brantacan.co.uk/cable_stayed.htm) where you will find a helpful summary comparing the features of cable-stayed bridges with those of suspension bridges.*

## 4. Using arches

### ARCH BRIDGES

The arch was used in structures built by ancient Egyptian and Chinese engineers, as well as in the buildings, bridges and aqueducts constructed by the Romans.

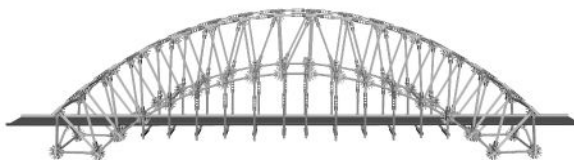

- **Construction and Materials**

The arch draws its strength from the ability of blocks of stone, (or concrete, bricks, wood, or steel), to withstand very large forces of compression. These forces hold the stones together between the abutments of the bridge.

In the arch bridge, the forces of compression are spread (dissipated) from one block to the next, along the curve of the arch towards its ends (abutments) and into the ground. The ground, in turn, pushes back on the ends of the arch, creating a resistance that is transferred from one block to the next until the **keystone**, or central block, is reached. When the arch bridge is made from masonry blocks, their shape is critical. Blocks (called **voussoirs**) must be wedge-shaped, as it is this shape that makes it possible for the arch to hold itself up. The wedge-shape ensures that each block is caught between neighboring blocks, preventing it from falling. If the blocks were rectangular, they could slip out of place, causing the bridge to collapse.

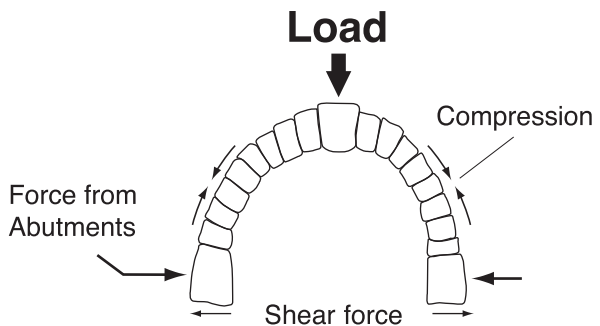

Fig. 15: Forces acting on an arch

All parts of an arch bridge are under compression – from the weight of the bridge deck pushing out along the curve of the arch and from the resistance of the ground pushing back (reactive force) on the abutments. Tension, by comparison, is a minor force in an arch, even on its underside, although the steeper the curve of the arch, the more tension is likely to be present.



## Reader 6

The use of abutments is a critical design feature of the arch bridge. Note how both ends of the Victoria Falls Bridge, which spans the Zambezi River and links Zambia and Zimbabwe, abut against the rock face of the ravine. These abutments prevent the ends of the bridge from thrusting outward.



Many older arched stone bridges were constructed from multiple arches. For example, the original London Bridge, the Ponte Vecchio in Florence, Italy and the Old Bridge in Beziers, France.

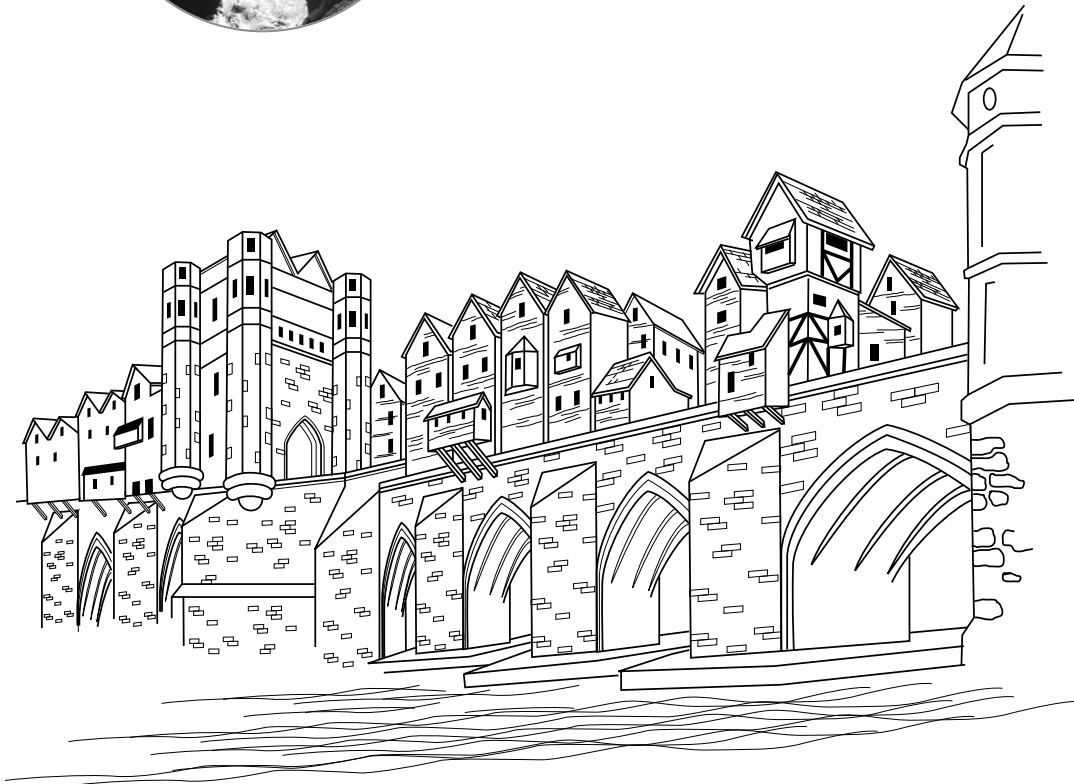

*Fig. 16: Old London Bridge*

With time, bridge materials improved and arch bridges were made with cast iron, steel and, more recently, with concrete. The longest single span arch bridges are around 500 meters in length.



## Moving Bridges BASCULE BRIDGES

The word **BASCULE** is French and means 'seesaw.' A bascule bridge is often used to cross rivers and canals and can be opened to allow the passage of ships. Its central span is divided into two sections called **leaves**. The ends of the leaves must be counterbalanced to reduce the effort needed to raise them. Each leaf is in fact a rotating cantilever.

The movable sections rotate upward to open the bridge and are operated by a system of counterweights, gears and motors. The counterweights themselves are typically made from concrete and are normally located below the roadway. A motor operates the opening mechanism; it turns the gears that move the counterweights down, while the leaves pivot up and open a passage for shipping.

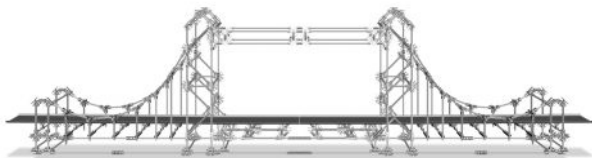

Tower Bridge, crossing the River Thames in London is a bascule bridge. Each bascule is approximately 33 meters (100 feet) long and each has a 422 ton counterweight attached at one end.



*Tower Bridge, London, England.*



*A castle drawbridge*

A drawbridge is a variation of a bascule bridge. Both types of bridge use the principle of the lever to operate.



*A bascule bridge opening for shipping*

## Bridge Disasters

Engineers must be concerned about safety at all times but occasionally bridges fail. When bridges collapse lives are at stake and the economy of a region may be affected. It is therefore crucial for structural engineers to investigate and learn from past mistakes in order to avoid similar disasters happening again.

Investigate further by visiting the following web sites:

[http://eduspace.free.fr/bridging\\_europe/disasters.htm](http://eduspace.free.fr/bridging_europe/disasters.htm)

[http://www.engr.utexas.edu/wep/COOL/AcidRiver/allaboutbridges\\_Disasters.htm](http://www.engr.utexas.edu/wep/COOL/AcidRiver/allaboutbridges_Disasters.htm)



# Skill Builder Teacher's Notes

## *An Overview for the Teacher*



### SECTION I

It is often assumed that all students know how to use construction kits simply because many of those used in schools have their origins as children's toys. Differences in opportunities and interests, however, resulting from gender, race/ ethnicity, socio-economic background, and ability will mean that such knowledge is far from universal in the classroom. With this in mind, teachers may want to provide opportunities for all students to become familiar with the different components that make up a kit, with the techniques used to fit them together, and with ways to identify them when trying to interpret building instructions. It is also important for students to recognize both the advantages and limitations of construction kits when used to model, test, evaluate and modify their ideas as part of the design process.

When designing and making their own models, students need to develop their sense of spatial awareness. The capability to visualize structures and/or working mechanisms is a skill that has to be learned and this can be best achieved by working in a 3-D environment. In addition, designing and creating, whether using a construction kit or not, requires students to have a knowledge and understanding of the properties of the materials with which they will be working, how they join or fit together and how they move in three dimensions.

The K'NEX construction system is easy to use, but it is recommended that students be given some free building time to explore and investigate the components before starting structured activities. The activities outlined in the Skill Builder section are designed to familiarize students with K'NEX components and to develop a K'NEX technical vocabulary that everyone can understand and use when describing their designs and their models. Concurrently, students will have the opportunity to learn the technical and scientific vocabulary needed to discuss and describe the concepts they observe and use in different bridge designs and structural design problems. Throughout the Skill Builder section, opportunities are presented to reinforce students' prior learning and to develop further their knowledge and understanding of how structures are designed and made.

By following the K'NEX Building Instructions when making the K'NEX Real Bridge models, students also learn how to interpret 2-D drawings to make 3-D models and to make their own 2-D drawings and plans from 3-D models.

Skill Builder activities are presented as a collection of **practical investigations**. Working through these activities enable students to develop their knowledge and understanding of basic concepts relating to structures, in general, and to bridges, in particular. In addition, students are encouraged to use different resources, including the Internet, to investigate and evaluate the design and construction of bridges, and to develop team building and problem solving skills.

The activities outlined in the Skill Builder section can be used sequentially or individually in the manner that best fits your own teaching program for this area of the curriculum.

#### **SUMMARY**

##### **Objectives**

Students will learn to:

- Become familiar with K'NEX building techniques and components.
- Explore how K'NEX components join together to make simple 2-D and 3-D shapes.
- Construct 3-D models from 2-D drawings.
- Develop a knowledge and understanding of stable and unstable shapes and simple structures.
- Use technical and scientific vocabulary in context.

##### **Key Skills**

Students will learn to:

- Understand and apply key concepts relating to structures.
- Develop 3-D spatial awareness.
- Work as part of a team.
- Problem solve.
- Use K'NEX resources effectively.

# Skill Builder 1

## Teacher's Notes

### *Building a Bridge Can't Be All That Difficult, Can It?*

#### INTRODUCTION

This is a 'free building' activity in which no prior knowledge of bridge construction is assumed. Students are provided with a limited set of resources and are given a limited 'design and create' task to carry out. Their performance in this activity establishes a baseline measure of their knowledge and understanding of structural engineering concepts and it is against this that individual progress can be monitored as they work through this part of the curriculum.

#### OBJECTIVES

- To establish the baseline knowledge and understanding of construction technology of the students through a limited investigation.
- By discussion, to help students identify some of the key problems that must be solved by structural engineers when designing and building structures.
- To introduce and use in context the technical and scientific vocabulary associated with physical engineering.

The activity can also be used as an introduction to the design process. A limited task to be completed within a set time, with limited resources, is a reflection of real life engineering design. The students will learn not only through trial and error, but also through reflection and discussion about how well their design worked. They will also discover that designing and making structures involves considering many factors in order to successfully confront the challenges of the project.

Teams of 2-3 students are presented with 3 challenges:

- Design and build the longest bridge, without a load, that will not **fail**.
- Design and build the longest bridge capable of carrying a small **load**.
- Design and build the longest bridge that can support a small load without **sagging** or **bending**.

#### MATERIALS

Each group of students will need

- 15 K'NEX Rods (any length)
- 15 K'NEX Connectors (any type)
- K'NEX Real Bridge Building Instructions Booklet (Page 2)
- 50g and 100g weights/slotted masses
- Rulers

#### VOCABULARY

*beam, load, dead load, live load, span, bending, sagging, rigid, fail, failure, strength, design specifications, structure*

#### CHALLENGE I

- Using only the specified materials, students design and make the longest bridge. It does not have to support a load, but it must not fail.
- The bridge does not have to be a free-standing structure, but can simply span the gap between two desks or two chairs.



## SECTION I

# Skill Builder 1

## Teacher's Notes



### SECTION I

- Students can use a **maximum of 15 K'NEX Rods** (of any length) and **15 Connectors** (of any type) in their bridge construction.
- Maximum thinking and building time allowed: 20 minutes.

### CHALLENGES II AND III

- Allow a maximum of 15 minutes for each challenge.
  - II. Using only the specified materials, students design and make the longest bridge that can span a gap and support a 100g load at its mid-point?
  - III. Using only the specified materials, students design and make the longest bridge that can support a 50g load without sagging or bending?

#### Question:

Of the three bridges each group has made, which is the strongest?

### PROCESS

#### WHOLE CLASS

- Allow a few minutes for students to select their construction materials from the K'NEX Real Bridge Building set.
- Before starting their 'design and create' challenge, students may be introduced to the K'NEX building tips shown on Page 2 of the Real Bridge Building Instructions Booklets.

#### WORKING IN GROUPS 2-3

- Students should be encouraged to spend a few minutes discussing how they might tackle the challenge before starting to build.
- They should be asked to record their ideas and observations. They may want to address some of the following areas:

- What ideas were rejected/accepted and the reasons for their decisions?
- How their bridge performed against their expectations/the design specification.
- What changes they made to the bridge structure during construction to make it meet the design specification.

Given that the students only have a small number of components to work with, the most likely bridge constructed will be a **simple beam bridge**.

In attempting to make a long bridge they should find that the beam will soon start to sag under its own weight (**dead load**) and a bridge more than 7 or 8 of the longer K'NEX rods in length may be so weak as to break under its own weight.

Students should also discover:

- In order to carry a load (**live load**) a bridge must be **structurally strong** enough to support both the dead load and the live load.
- Long **span** beam bridges have a lower load bearing ability when compared to short span beam bridges made from the same pieces and to the same design.

K'NEX structures, along with many other structures, are likely to fail where structural components are joined together. It is at the joints or connections that stress forces focus. Any weakness here will result in structural failure. Careful observation of the connections in their K'NEX model will show how they may be forced apart by bending forces.

### ASSESSMENT

- After the construction and testing, students should provide a short report of approximately 100 words on the strengths and weaknesses of each of their 3 bridges.



# Skill Builder 1

## Teacher's Notes

### WHOLE CLASS

- Discuss the merits and issues raised by the success and failure of each group's design.
- What did the students learn about bridge structure and function? How and where did their structures fail?
- Why is it important for the beam to remain **rigid** when subjected to a load?
- What changes might they make to strengthen their design so that the beam will remain rigid over a longer distance, even when a load passes over it?
- How do structural engineers solve the problem of maintaining a stiff bridge span structure over long distances? Refer the students to the photographs in the K'NEX Real Bridge Building instruction booklets or visit [www.brantacan.co.uk](http://www.brantacan.co.uk).
- Discuss how most people take it for granted that a bridge will not sag when they drive or walk across it. Would the students feel safe using a bridge that sagged? Automobiles and trucks would also find it difficult to use such a bridge. Additionally, it is not only the live and dead loads that must be taken into consideration but also **environmental loads** such as wind, snow, ice and currents of water.
- You may also wish to introduce the importance of the choice of materials in bridge design. Explain how the ability of engineers to design and construct longer and longer bridges only advanced with the discovery and use of new technologies and materials. Wood and stone were superseded by cast iron, wrought iron and then steel. Today many bridges are constructed using reinforced concrete and/or a combination of different materials. Understanding the physical properties of materials and how they behave when subjected to different types of forces is essential knowledge for any successful structural engineer.

### Reference Material for Upper Grade Levels

- *Reader # 4: Stress, Strain, Stiffness and Young's Modulus.*

### EXTENSION ACTIVITIES

To extend the activity you may find it useful for students to investigate some famous bridge disasters such as the Tacoma Narrows Bridge in 1940; the Quebec Bridge 1907, 1916 and the Tay Railway Bridge 1897. Film footage and photographs of the Tacoma Narrows Bridge failure is available on a number of web sites.

<http://www.ketchum.org/bridgecollapse.html>

Provides references to a number of bridge collapses, video footage of the Tacoma Narrows Bridge and graphics of the Tay Railway Bridge disaster.



## SECTION I

## Skill Builder 2 Teacher's Notes

# Investigating 2-D Shapes Rectangles and Squares



### SECTION I

#### INTRODUCTION

In this activity students investigate the effects of forces acting on **rectangular frame** structures. The activity also offers a context within which to introduce technical vocabulary relating to structures and the forces acting on them.

#### OBJECTIVES

Students will:

- Investigate the effects of forces on rectangular and square shapes.
- Learn, understand and use technical vocabulary correctly.

#### MATERIALS

- K'NEX Real Bridge Building set(s)
- A piece of solid foam rubber approximately 30 x 6 x 6cms (12 x 2 x 2")
- Marker
- Rubber bands – at least 12.5cms (5") long
- Access to the Internet

#### VOCABULARY

*stable, unstable, strength of structures, strength of materials, frame, structure, member, strut, tie, compression, tension, shear, distort, stress, compressive stress, tensile stress, equilibrium, lateral applied forces.*

#### THE INVESTIGATION

- To make as many different sized rectangles and squares with the available components and to investigate the effects on them of external forces.
- Each team selects blue, red and gray Rods and an assortment of Connectors from which they will construct 3 different sized squares and 1 rectangle. The rectangle should be made using blue and either red or gray Rods.

**SAFETY NOTE:** Please refer to the beginning of the Guide for information on the safe use of rubber bands in the classroom. Protective glasses/goggles should be worn during the activities described below. This is sound safety practice for the science/technology classroom or lab.

#### PROCESS

##### WORKING IN GROUPS 2-3

- Explain how a rectangle is one example of a **frame structure**, made by joining together a number of parts or **members**.
- Discuss how the strength of a structure lies in its ability to resist being distorted or deformed when external forces are applied to it.
- Use simple drawings on the board and/or use the Student Inquiry Worksheets to introduce the investigations and the vocabulary to be used.

# Skill Builder 2

## Teacher's Notes

- Students will use their models to carry out a simple investigation of the **strength of rectangular frame structures**.
- They should be encouraged to record their observations through drawings, using directional arrows to indicate **compression**  $\rightarrow \leftarrow$  and **tension**  $\leftarrow \rightarrow$ , and write notes, using the correct technical vocabulary.

### EXPECTED OUTCOMES

Applying external forces to squares and rectangles will affect their shape, especially of those with longer sides. Students should find that as external forces are applied, the joints on the K'NEX Connectors begin to open. **At this point no further pressure should be added to the structure.**

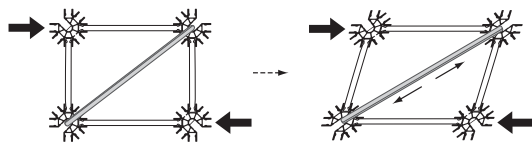

Shearing forces

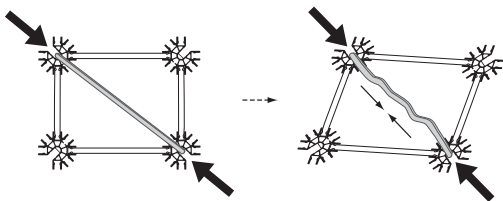

Compression forces

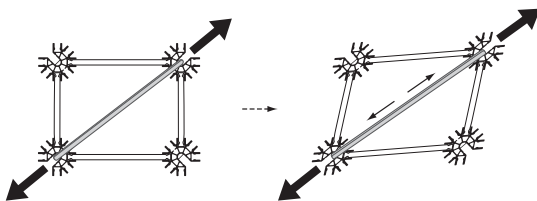

Tension forces

To help visualize what is happening, it is useful to place a rubber band, under a small amount of tension, in line with the applied forces. Additional stretching or relaxation of the band shows lines of compression or tension in the structure.

*Suggestion: Use 4 yellow Rods and 4 blue Connectors. Hook the ends of the rubber band over the prongs of the opposite Connectors. Use a rubber band that is at least 3/4 the length of the diagonal of the quadrilateral. If you use the arrangement suggested above you will need a rubber band that is approximately 12.5cms (5") long.*

### WORKING IN GROUPS 2-3

- Ask: **Does the addition of more squares or rectangles make the structure stronger?**
- Each group should make a chain of squares or rectangles and investigate the effect of external forces on this structure. (Additional K'NEX Rods and Connectors will be needed). For example:

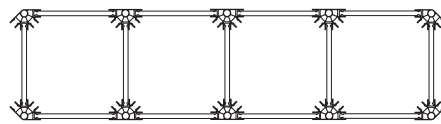

Students will discover that a chain of repeating shapes does not increase the stability of the structure. It will still distort when subject to shear and that even small downward forces at its center will cause it to bend. They should also note that the joints on the bottom are forced open indicating that this part of the structure is under tension.

### WHOLE CLASS

- Review student results.
- Rectangles and squares are easily distorted by external forces and are therefore unstable structures.



# Skill Builder 2

## Teacher's Notes



### SECTION I

- Joints are often weak points in many structures and are points where structural failures may occur.
- K'NEX structures, along with many other structures, are likely to fail where structural components are joined together. It is at the joints or connections that stress forces focus. Any weakness here will result in structural failure. Careful observation of the connections in their K'NEX model will show how they may be forced apart by bending forces.
- Explain that rectangles and larger polygons are **unstable** because external forces acting on them easily distort their shapes. This can be explained in terms of balanced and unbalanced forces as determined by **Newton's First Law of Motion**. This states that an object will remain at rest unless it is acted on by a force that makes it move in the direction of the applied force.
- When a student pushes a structural member in a K'NEX square/rectangle, that member will move from its rest position, resulting in the distortion of the square. The shape, however, will only be distorted if the applied external force is larger than the structure's ability to push back against it. The movement of the structure will be in the direction of the larger force.
- How do structures/inanimate things push back?

Demonstrate by allowing students to stretch rubber bands. As the students pull the ends apart they feel a force working in the opposite direction.

What happens to their K'NEX models when they remove the external force? It returns to its original shape. If, however, the size of the applied force is the same as the structure's resisting forces, the forces acting in the structure remain **balanced**, their net sum equals zero. The structure is **stable** and will not change shape.

**IMPORTANT SAFETY NOTE:** If the structure is squeezed too hard the joints may snap open ejecting one or more connecting Rods from the structure. While this effect demonstrates a dramatic failure of the structure, students should be instructed not to exert too much force because of the potential hazard from the ejected rods. **Wearing protective eyewear is advised.**

### EXTENSION ACTIVITY

- You may wish to introduce the concept of strong and weak structures at this point. The strength of a structure is measured by the size of the external forces needed to make it break or **fail**. For example: rectangles and squares are weak or unstable structures because their shapes can be **distorted** easily when forces are applied.

#### *Reference Material for Upper Grade Levels*

- **Reader #4: Stress, Strain, Stiffness and Young's Modulus**

### THE INVESTIGATION

Students will carry out a simple investigation to find out what happens when compression and tension forces are applied to a structural member – in this case a plastic K'NEX Rod. The forces are applied by gently squeezing a K'NEX rectangle by hand. The students should try with different sized rectangles/squares.

### PROCESS

#### WORKING IN GROUPS OF 2-3

- Ask: **From the students' experiences in Skill Builder 1 can they predict what might happen?**
- Students push the sides of their K'NEX rectangle inwards (**lateral applied forces**) and observe the effect on the shape.

# Skill Builder 2

## Teacher's Notes



### SECTION I

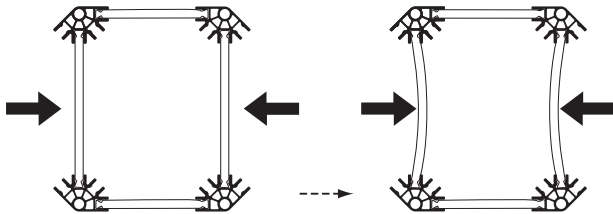

Forces are applied at right angles to the long axis of the side members.

- Next, ask students to place the K'NEX model vertically on the desktop and push down on one of its edges.

In other words, the external force is applied along the axis (**axially**) of a K'NEX rod.

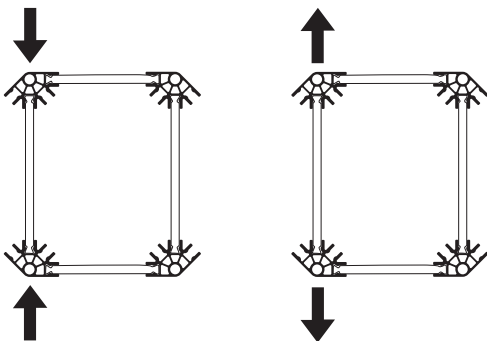

### WHOLE CLASS

- Review student results.
- Ask: **Did the shapes behave as you expected? Describe and explain your observations.**
- Students should observe that long structural members bend more easily than shorter ones.

When external forces are applied at right angles to the long axis of structural members, they bend in a similar way to a beam bridge. The top and bottom members may also be affected.

An earlier activity referred to the need for structural engineers to have an understanding of the physical properties of materials. This knowledge enables them to predict how those materials may behave when used in structures.

This may also be a relevant time to introduce the ideas relating to **strength of materials**. The **strength of a material** is a measure of how much force must be applied to it to make it break or fail.

You may wish to explain that the way in which a structural member behaves is dependent on how the external forces are applied. Ask the students to consider the following situations:

1. **Force is applied at right angles to the long axis** but the internal forces operating in the beam are not strong enough to resist.

**Expected outcome:** The structural member bends. Bending causes compression on one side of a structural member and tension on the other.

- Demonstrate to the class compression and tension in a beam using a piece of foam rubber marked along one side with parallel lines equidistant from each other, as shown below.

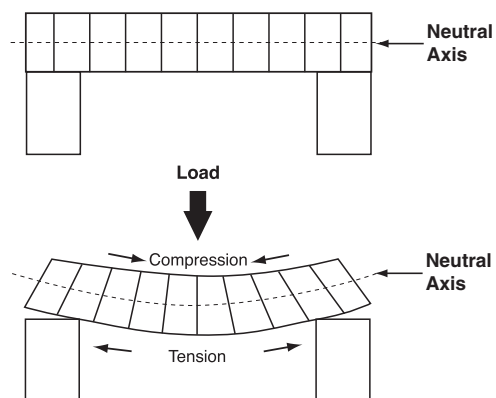

# Skill Builder 2

## Teacher's Notes



### SECTION I

As the beam bends, the lines on the top surface of the beam move closer together showing that the top of the beam is being squeezed, or is under compression, while those on the lower surface are stretched further apart, showing that the bottom is under tension. At the **neutral axis** of the beam it is neither in compression nor tension.

#### 2. Force is applied axially.

**Expected outcome:** Applying force to the edge of a K'NEX square does not make it move because two things are happening: 2.1. A student's downward pushing force is balanced by an upward force (**reaction**) from the table. The harder the student pushes down, the more the desk pushes back. The K'NEX model does not move; it remains at **rest**.

The net difference between the downward and upward forces is zero. Put another way, the forces acting on the K'NEX model are in **equilibrium**. Under these conditions, the K'NEX rectangle is stable.

2.2. The K'NEX structural members in the model are squeezed between two external forces, one from the student and the other from the desk. So why is it not squashed? It is, by a very small amount. Structural members are at their strongest when external forces act axially. If these forces do not act axially then the member will be subjected to both compressive and tensile forces that may cause it to bend, resulting in possible failure of the structure.

#### Stress in materials

Every material is made up of atoms and/or molecules that are packed together. The atoms/molecules set up internal forces that resist compression and tension. These **internal forces are called stresses**. **Compressive stress** prevents a material from being squeezed and **tensile stress** prevents it from being stretched or lengthened. How well a material resists external forces is a measure of its **strength**.

#### WHOLE CLASS

Discuss whether rectangles and squares are good shapes to use in structures.

Ask: **How can weak rectangular frame structures be made into strong structures?**

#### EXTENSION OF CONCEPTS (OPTIONAL)

In a follow-up to this lesson you may wish to expand on the concepts of **stress, strain and elasticity** in materials.

For example:

**Stress** as a measure of how much the atoms/molecules in materials resist being pushed together or pulled apart by external forces of compression and tension. It is a measure of how much force is being applied per unit of area of the material.

$$\text{Stress} = \text{Force}/\text{Area}$$

**Strain** as a measure of the how far the molecules of a material are being squeezed together or pulled apart by the external forces of compression or tension. To measure strain, the **change in length** of the material produced by external forces is compared with its original length.

$$\text{Strain} = \text{Change in length}/\text{Original length}$$

All materials will show a change in length when put under strain. This change in length may be quite large, as with a rubber band or extremely small, as in a steel block. When the strain is removed, the material will return to its original length (Reference: **Hooke's Law**).

**Elasticity** as the amount of strain a material will take before it becomes permanently distorted. Elasticity provides a measure of the **stiffness** of a material.

# Skill Builder 3

## Teacher's Notes

### Investigating 2-D Shapes - Triangles

#### INTRODUCTION

In this activity students investigate the effects of forces acting on **triangular frame** structures. The activity also offers a context within which to introduce technical vocabulary relating to structures and the forces acting on them.

#### OBJECTIVES

Students will:

- Investigate the effects of external forces on triangular shapes.
- Investigate how triangles are used to make strong, light structures.

#### MATERIALS

- K'NEX Real Bridge Building set(s)
- Rubber bands (assorted sizes)

#### VOCABULARY

*stable, unstable, strength of structures, strength of materials, frame, structure, member, strut, tie, compression, tension, shear, distort, stress, compressive stress, tensile stress, equilibrium, lateral applied forces*

#### THE INVESTIGATION

- To make as many different sized triangles as possible with the available components and to investigate the effects on them of external forces.
- Each team selects 3 K'NEX Rods of each kind and 3 Connectors of each main type.

**SAFETY NOTE:** Please refer to the beginning of this Guide for information on the safe use of rubber bands in the classroom. Protective eyewear should be worn during the activities described below. This is sound safety practice for the science/technology classroom or lab.

#### PROCESS

##### WORKING IN GROUPS OF 2-3

- In this activity the students will carry out a simple investigation into the strength of triangular frame structures. Use simple drawings on the board and/or the Student Inquiry Worksheets to introduce the investigations and the vocabulary to be used.
- Explain that a triangle is another example of a **frame structure**, made by joining together a number of parts or **members**.
- Ask each group to construct a range of different sized triangles and to investigate what happens when they apply force to the corners and sides.
- Different sized right-angled triangles can be made using the components available. The students should be encouraged to investigate the effects of forces on triangular shaped structures by applying a force at (i) the apex and (ii) the sides.

##### 1. Vertical Applied Force

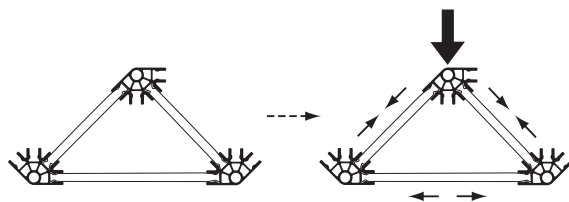

#### SECTION I

# Skill Builder 3

## Teacher's Notes

SECTION I

With a vertically applied force, the triangle's shape remains the same, demonstrating that triangles are strong, **rigid** structures that do not distort easily under this type of load.

### 2. Lateral Applied Force

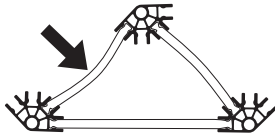

A laterally applied force, however, may cause the sides of the triangular structure to bend inwards. Short Rods are better at resisting such bending forces than long Rods. See Important Safety Note: Skill Builder 2.

- Replacing the base K'NEX Rod with a rubber band demonstrates how forces act in a triangular frame structure. We suggest using a triangle constructed from 2 yellow Rods, 1 red Rod and 3 blue Connectors. A 12.5cm (5") rubber band can replace the red Rod by hooking its ends over the large gaps in the blue Connectors.
- When a force (load) is applied – in this case pressing down with a finger at the apex of the triangle – the apex acts like a hinge and the two sides spread apart. The rubber band is stretched and demonstrates that this part of the structure is under tension. The students should feel a force pushing back on their finger. This is the **reaction** force and is produced by the tension forces that are created in the rubber band as its molecules resist being pulled apart. The force stretching the rubber band is the tensile stress.

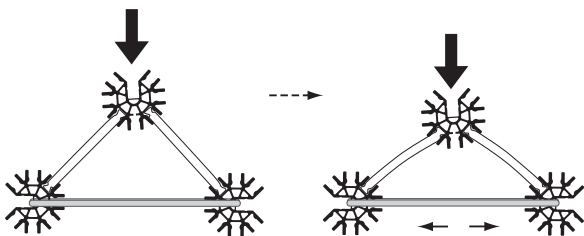

- Replace the rubber band with a red K'NEX Rod and push down again. The sides of the triangle do not spread apart and the student will feel a much stronger reaction force acting against his/her finger. In this case the internal tension forces produced by the K'NEX Rod molecules as they resist being forced apart, equals the tensile stresses produced by load. In this example:

**The total downward external force = The total internal reaction force in the opposite direction**

The sum of the external and internal forces is zero and so the triangle is in equilibrium and is stable.

In reality the tensile strength of a K'NEX Rod is so large that the joints of the model will spring open causing a dramatic failure of the structure.

- A rubber band replacing one side can also demonstrate a side under compression.

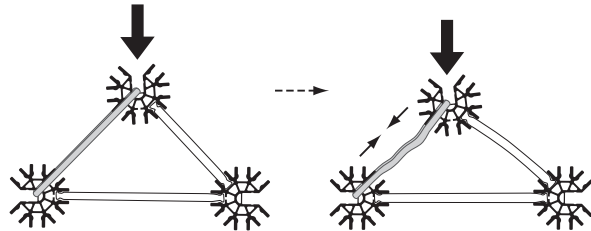

*Note: When replacing the K'NEX Rod, the rubber band should be under a small amount of tension.*

- Ask the students to describe the effects of compression on the sides of a triangle using the correct vocabulary. For example: compression; compressive stress; equilibrium; stable; reaction; internal and external forces.
- Extend the activity by asking each pair to make a short chain of triangles. (Additional K'NEX Rods and Connectors will be needed). What happens when external forces are applied to this structure?



# Skill Builder 3

## Teacher's Notes

For example:

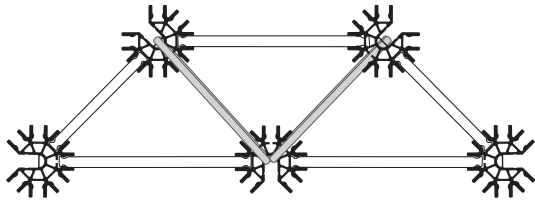

- Students should discover that a **framework** or **lattice** of triangles (also called a **truss**,) produces a very strong structure and that even quite large forces cannot easily distort its shape.

*Rubber bands replacing the members (shown above,) can be used to help students visualize some of the forces acting on this structure. The rubber bands should be under slight tension and can be held in position by hooking them round the prongs of the blue Connectors.*

- If one student places one end of their truss on the edge of a desk and holds the other end in their hand, their partner can exert a force (load) at the middle of the lower long edge. As the load is applied, the rubber bands will stretch and pressure can be felt on the other partner's hand.
- Ask your students to draw and record those parts of the structure (members) that are under compression and tension when a load is applied to the central section.

For example:

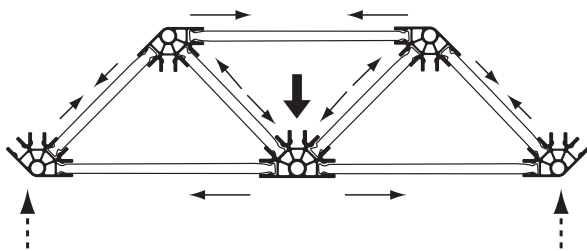

*The broken arrows represent the reaction of the desk/hand.*

- Now ask your students to find the longest linear structure they can make using triangles that will not sag under its own weight or a small load. *It may be easier and faster if groups simply combine their models together to make longer bridge sections.*
- How does this structure compare to the simple beam bridge structure they made in the Skill Builder #1 Challenge?

### EXPECTED OUTCOMES

Students may be surprised to find that they can build a single span about 1m in length that remains rigid even when loaded. The beam, however, is likely to twist easily because of the effects of **torsion** and may need support. Simply rotating their structure through 90-degrees reproduces a long simple beam bridge enabling the students to compare the two types of structure.

- Can they explain the differences in the performance of the two structures?
- The students should be encouraged to record their observations through drawings, using directional arrows to indicate **compression**  $\longrightarrow \longleftarrow$  and **tension**  $\longleftarrow \longrightarrow$ , and write notes, using the correct technical vocabulary.

### WHOLE CLASS

- Review with the students the way in which the long K'NEX bridges they constructed in Skill Builder #1 sagged in the middle. You may want to demonstrate using a selection of gray K'NEX Rods. Encourage the students to think about why the structures sagged.
- Gravity acts to pull down on the beam and makes it bend or sag. (This is in effect the



SECTION I

# Skill Builder 3

## Teacher's Notes

### SECTION I

weight of the beam, or the dead load.) To resist this bending or sagging effect, compression forces develop in the top and tensile forces develop in the bottom sections of the beam. A beam will continue to sag until the forces within it balance the forces due to gravity – **action and reaction**. (*Science reference: Balancing Forces/Newton's Third Law of Motion*). If the internal forces in the beam are greater than the force of gravity, the beam retains its stiffness and remains rigid. If, however, gravitational forces are greater than the internal forces in the beam, it will break.

- Explain how a beam can be made stiffer and more rigid by increasing its thickness or depth.
- Demonstrate using equal lengths of different sized square section wood/balsa wood or dowelling. Find and record on the board the maximum load each piece can support; ask students to plot load against section area and interpret their results.

- Ask: **Does making a beam thicker have any disadvantages when building a bridge?** Look for answers that mention (i) adding weight and (ii) adding cost to the structure.
- Explain how a beam can be increased in depth, without significantly increasing its weight, by using **struts** and **ties** to produce a latticework of triangles called a truss. Trusses use the **principle of triangulation** to achieve rigidity in a structure.

A **truss structure** allows the forces that operate within it to be distributed across its framework and enables engineers to make structures rigid without making them heavier. By extending the truss sideways it is possible to make structures that are not only long and rigid, but also light in weight.

- If appropriate you may wish to introduce the concept of the **span-depth ratio** as applied to beams and how it allows engineers to estimate a suitable thickness for the beam. (Please refer to **Reader #3: Bridges and Forces 2** for more information on this topic.)

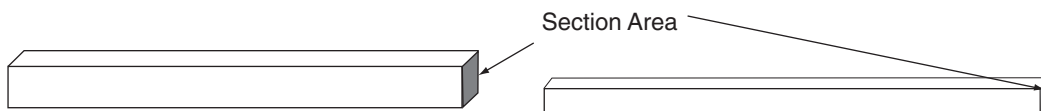

**Data Table**

	Section Area "1"	Section Area "2"	Section Area "3"	Section Area "4"
Maximum load supported				

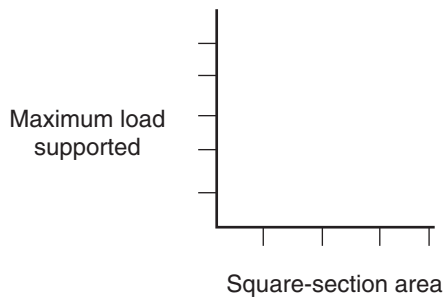

# Skill Builder 3

## Teacher's Notes

### BACKGROUND RESEARCH AND INVESTIGATION USING INFORMATION

#### TECHNOLOGY SOURCES:

Provide time for the students to explore the following web sites:

- “Building Big” at <http://www.pbs.org/wgbh/buildingbig/lab/index.html>  
This is an excellent site containing “Labs” for students to investigate different types of forces, the effects of forces on shapes and materials, and loads on structures. The web site is highly visual and covers many key concepts in a simple and effective way.
- [www.howstuffworks.com/bridge](http://www.howstuffworks.com/bridge)  
A good general website on bridges, with a helpful section on truss construction.
- Ask the students to identify the types **materials** used in the construction of different types of bridges and other large structures. What is the function of the materials they identify and what forces must the materials withstand in their named structures? How do their physical properties make them suitable materials for their intended function?
- Students could be asked to write a short report of 200 – 300 words each on: “How materials/structures behave when subjected to external forces.”

### EXTENSION ACTIVITY

#### How trusses are used in large structures

- Refer your students to the K’NEX Real Bridge Building models and building instructions and Internet web sites such as [www.brantacan.co.uk](http://www.brantacan.co.uk) and [www.howstuffworks.com/bridge](http://www.howstuffworks.com/bridge) to investigate the advantages of using trusses in large structures.

- <http://bridgecontest.usma.edu/tutorial.htm>  
An excellent web site: The West Point Bridge designer software allows students to design virtual bridges. (Note: you will need to download the software first.) Students could then realize their virtual designs using their K’NEX Real Bridge Building sets.
- Separate groups could construct bridge spans using different truss construction patterns and compare their load bearing capabilities. Which pattern gives the strongest structure over the longest span? Did their virtual design behave as expected?
- Ask the students to select at least one example of each application and produce a short, illustrated report of no more than 250 words on how truss construction has been used in the design of their chosen structure.



## SECTION I

# Skill Builder 4

## Teacher's Notes

### Strengthening 2-D Shapes



#### SECTION I

#### INTRODUCTION

This activity is a progression from Skill Builder #2: Investigating 2-D Shapes – Rectangles and Squares and Skill Builder #3: 2-D Shapes – Triangles, in which students use the principle of triangulation to strengthen a weak frame structure. The activity also offers a context within which to introduce technical vocabulary relating to structures and the forces acting on them.

#### OBJECTIVES

Students will:

- Investigate how rectangular structures can be reinforced by triangulation.
- Explore how triangulation can involve the use of compression members (struts) and tension members (ties).

#### MATERIALS

- K'NEX Real Bridge Building set(s)
- Rubber bands (assorted sizes)
- String (approximately 30 cm or 12 in)
- Paper or light card
- Scissors
- Single-hole punch

#### VOCABULARY

*beam, triangulation, brace, diagonal brace, strut, tie, compression, tension, members, stable, unstable, stabilize, strong, rigid, stress, queen post truss, king post truss, diaphragm*

#### THE INVESTIGATION

- To investigate how rectangular frame structures can be strengthened to resist compression, tension and shear forces at their corners.

#### PROCESS

##### WORKING IN GROUPS OF 2-3

- Students select components from their K'NEX Bridge Building set to make 3 different sized squares and 1 rectangle.
- Ask each group to build their K'NEX structures.
- Review what happens when forces act on a square/rectangular structure – Skill Builder #2 and a triangular structure – Skill Builder #3.
- Review their suggestions from Skill Builder #2 as to how the square frame structure can be strengthened to prevent it being distorted by external forces. They should be reminded of the role played by a diagonal brace (in this case a K'NEX Rod) and should insert one into their frame structure and then apply external force. (See below: A1, A2 and A3.)

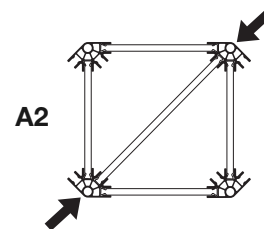
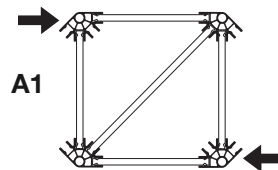

# Skill Builder 4 Teacher's Notes



## SECTION I

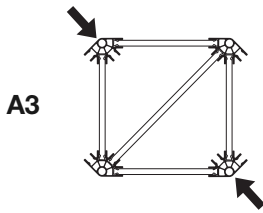

### EXPECTED OUTCOMES

- Students should discover that when force is applied in any of the situations shown above, the structure retains its shape and is structurally stable.
- This **diagonal brace/member** is called a **strut** when under compression and a **tie** when under tension.
- Replacing the base K'NEX Rod with a rubber band demonstrates how forces act in a triangular structure. (See Skill Builder #3 for additional details.)
- Students should be encouraged to record their observations through drawings, using directional arrows to indicate **compression**  $\rightarrow \leftarrow$  and **tension**  $\leftarrow \rightarrow$  and written notes that incorporate the correct technical vocabulary.
- To remind students of the way in which rectangles behave when unstable, ask them to remove the diagonal member and repeat the activity.

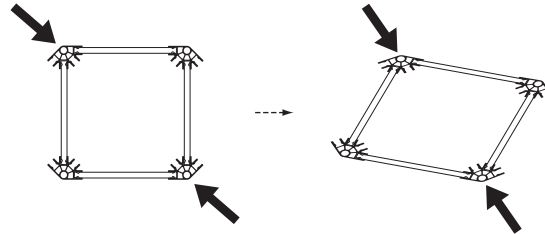
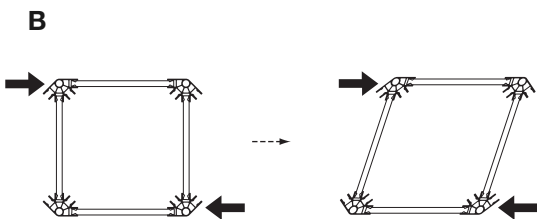

### WHOLE CLASS

- Ask:
  - What shapes were present in A, but not in B?
  - How does the inclusion of triangles make an unstable structure, such as a rectangle, stable?
  - What forces are acting on the diagonal member in A1, A2, and A3?
- Discuss how rectangular shapes can be made structurally **stable/stronger** by **triangulation**. Triangulation helps to create **rigid** structures.
- You may want to discuss and have the students investigate the designs of the King Post and Queen Post Trusses. They can be easily made using K'NEX components from the Real Bridge Building set.

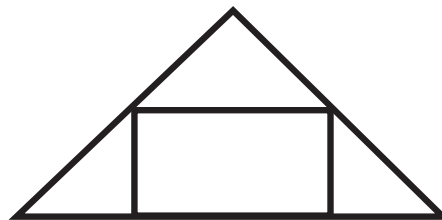

Fig. 1: Queen Post Truss



Fig. 2: King Post Truss

# Skill Builder 4

## Teacher's Notes

- Ask the students to record these shapes in their journals and to explain which one is the more stable structure and why. They should then build and test the structures by applying some force at the corners of the triangles.
- Suggest they investigate a third design.

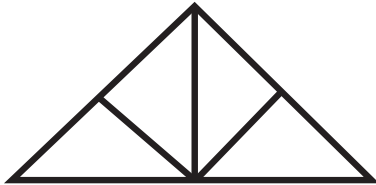

Fig. 3

**SAFETY NOTE:** Care should be taken not to apply so much pressure that the Rods are pushed out of their Connectors.

- Building and testing these structures will show that Fig.1 exhibits some instability. The central part is an un-braced rectangle. Fig. 2, on the other hand, is composed entirely of triangles and is more stable.
- Explain that triangulation must be used correctly to create stable structures. Fig. 1 can be made stable (stabilized) by the addition of a diagonal bracing strut.

**How to construct the shapes:**

(You may want to have a sample of each figure pre-made for reference purposes.) Students will need the following K'NEX pieces from their Real Bridge Building set:

- 7 yellow Rods
- 12 blue Rods
- 7 yellow Connectors
- 4 light gray Connectors
- 2 gray Connectors

Figure 1.

- (i) The base is made from 2 blue Rods and 1 yellow Rod (in the middle) joined by 2 yellow Connectors. At each end add a light gray Connector.

- (ii) Construct each side using 1 yellow Rod and 1 blue Rod joined by 1 yellow Connector. Complete the triangle by adding a gray Connector at the apex.
- (iii) Make the central rectangle by adding 2 blue Rods and 1 yellow Rod.

Figure 2.

- (iv) Build the base using 2 yellow Rods joined by 1 yellow Connector. At each end add a light gray Connector.
- (v) Construct each side using 2 blue Rods joined by 1 yellow Connector. Complete the triangle by adding a dark gray Connector at the apex.
- (vi) Use a yellow Rod for the vertical column.

Figure 3.

- (vii) Using Figure 2, add 2 blue Rods.

### WORKING IN GROUPS OF 2-3

- Ask each group to replace the K'NEX diagonal member of their rectangle with a length of string, test as before and observe what happens to the string when forces are applied to the structure.
- Ask: What forces are acting in the structure and string?

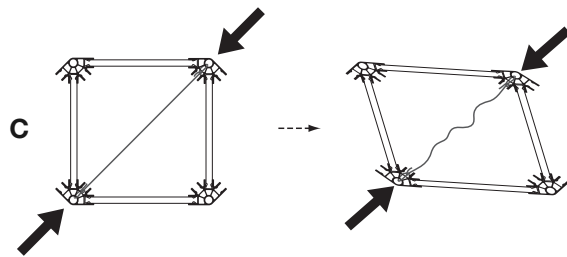

Students should note:

**C:** The structure will change shape because string is strong under tension but not under compression.

# Skill Builder 4

## Teacher's Notes

D

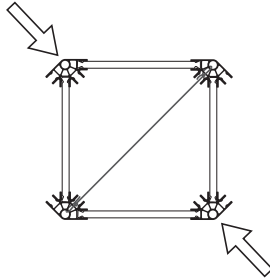

**D:** The structure does not change shape because the forces are acting along the length of the string.

You may want to explain that materials such as string, rope and steel cabling are strongest under tension – they have a high **tensile strength**.

Having a high tensile strength means a material can withstand very large stretching loads before it breaks. This is the reason why steel cables are used in suspension and cable-stayed bridges.

E

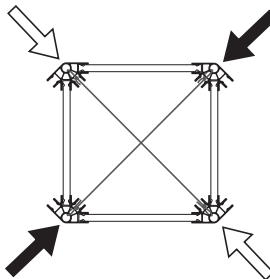

**E:** The structure will retain its shape because in whichever direction forces are applied, one of the two string members will be under tension.

F

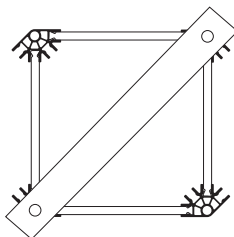

**F:** Place the square structure on a flat surface and insert white Rods vertically into the holes in diagonally opposite corner Connectors. Punch holes at each end of a strip of paper or thin card and fit them over 2 white Rods.

G

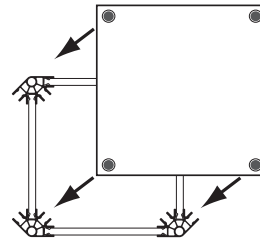

**G:** A similar exercise could be carried out with a sheet of paper cut to the same size as the K'NEX flexible square. In this case the paper is acting as a tension member.

In this example, once the paper sheet is in place it acts in the same way as the diagonal members in A.

### WHOLE CLASS

Discuss how these methods of reinforcing structures are used in real structures.

### EXTENSION ACTIVITY

#### Applying the concepts

This investigation requires teams of 4-6 students to examine the forces acting on different parts of a K'NEX Real Bridge structure while it is supporting a load.

Because one K'NEX Real Bridge Building set supports the simultaneous construction of any **two bridges**, at any one time 8-12 students can be involved in the construction of, for



SECTION I

# Skill Builder 4

## Teacher's Notes

example, the Dames Point Cable-stayed Bridge from Building Instructions Book 1 and the Firth of Forth Bridge Rail Bridge from Book 2. You can print additional copies of the Building Instructions from the CD-ROM that accompanies the set.

As part of their investigation students could be asked to:

- Identify which parts of the structure are under tension and compression?
- Which members are struts and ties?
- What parts might be removed without affecting the load bearing ability of the structure?
- Which parts are essential to the load bearing ability of the structure?

In addition, students could investigate approved Internet web sites such as [www.brantacan.co.uk](http://www.brantacan.co.uk) and [www.howstuffworks.com/bridge](http://www.howstuffworks.com/bridge) to explore further the function of structural components in bridges.

Students should be encouraged to make use of their Information Technology skills to incorporate photographs of structures downloaded from approved Internet web sites into a written report on their findings. They could also be encouraged to use a digital camera to record their bridge loading tests. Reports should be compiled from at least two web sites and should be restricted to no more than 500 words.



### SECTION I



# Skill Builder 5

## Teacher's Notes

### Making 3-D Frame Structures - Cubes

#### INTRODUCTION

The 3 activities outlined here continue the progression from Skill Builders #3 and #4 in which students investigated 2-D shapes and the use of triangulation to strengthen rectangular frame structures. In this series of tasks and investigations they will explore 3-D frame structures and investigate the effects of forces acting on them.

Through discussions, maintaining journal notes and report writing, the activities offer a context within which to introduce technical vocabulary relating to structures and the forces acting on them.

There are also opportunities for students to develop their Information Technology skills by using Internet search engines to obtain, evaluate and collate information for inclusion in a report.

#### OBJECTIVES

In Skill Builder **5A** students will:

- Investigate how 3-D frame structures can be reinforced/strengthened using:
  - (a) triangulation
  - (b) tension members
- Undertake a series of short investigations (total time 20-30 minutes) working in small groups of 2-3.

In Skill Builder **5B** students will:

- Investigate how long, rigid beams can be constructed using triangulation.
- Understand that there is a relationship between rigidity, span and depth of a beam – the span/depth ratio.

- Appreciate that there are limitations to the distances a simple beam bridge design can span.
- Practice their planning skills while working as a team.

In Skill Builder **5C** students will:

- Investigate how large structures, such as bridges, apply the concepts explored in Skill Builders 5A and 5B into their design so as to resist structural and environmental forces.
- As part of a group of 4-6, undertake a longer investigation (total time of 1-1.5 hours) of the K'NEX Astoria Bridge model.

#### MATERIALS

- K'NEX Real Bridge Building set(s)
- Building Instructions Booklet
- Rubber bands (assorted sizes)
- String and scissors
- Books or weights (10g-1000g)
- Card
- Top loading/top pan balances – Skill Builder 5B

#### VOCABULARY

*strength, stability, beam, brace, diagonal, member, strut, tie, compression, tension, shear, torsion, triangulation*



## SECTION I

# Skill Builder 5 Teacher's Notes

## Skill Builder 5A

### THE INVESTIGATION

1. To construct a cube from K'NEX materials.
2. To investigate: (a) the load bearing ability of a cube structure and (b) the effects of tension, compression, shear and torsion on a 3-D frame structure.

### PROCESS

#### WORKING IN GROUPS OF 2-3

- Ask the students to select EITHER 12 blue Rods, 8 blue Connectors and 8 dark gray Connectors OR 12 red Rods and 16 dark gray Connectors to make a K'NEX cube as shown below.

*NOTE : One K'NEX Real Bridge Building set contains enough parts to make 5 red cubes and 3 blue cubes simultaneously.*

- You may find it useful to draw this shape on the board for students to interpret.

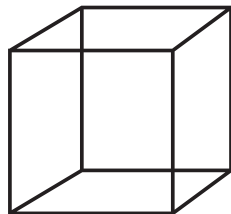

- This activity requires students to interpret the drawing of a simple 2-D line drawing and convert it into a 3-D K'NEX model. Draw attention to the technique for joining the blue and the dark gray Connectors to form corner joints. Refer to Page 2 of the Building Instructions booklet if necessary.

### WHOLE CLASS

Review the students' findings and observations from Skill Builder #2: Investigating 2-D shapes:

- How did different forces affect rectangular and square 2-D frame structures?
- Ask them to predict what they think will happen to a 3-D square frame structure when these forces are applied.
- Do they expect it to be stronger or behave in the same way as a 2-D square?
- Ask them to explain their answers.

### 1. USING TRIANGULATION

#### WORKING IN GROUPS OF 2-3

- Ask each group to test their predictions and investigate the load bearing ability of their cubes by adding books or weights.
- What is the largest load the cube can support without failing?
- Groups should compare the results from the different sized cubes and note the results in their journals/workbooks.
- Ask the students to apply forces to the sides of the cube as in Skill Builder #2 activities. For example:

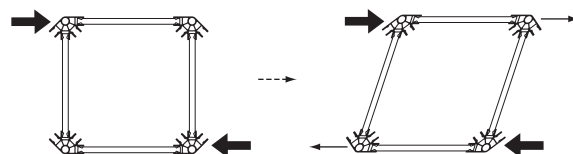

Shear forces

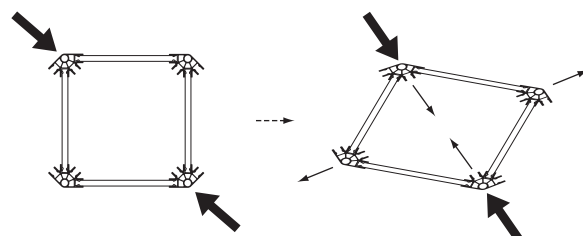

Compression forces

# Skill Builder 5

## Teacher's Notes

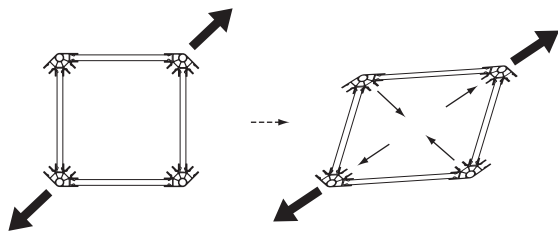

Tension forces

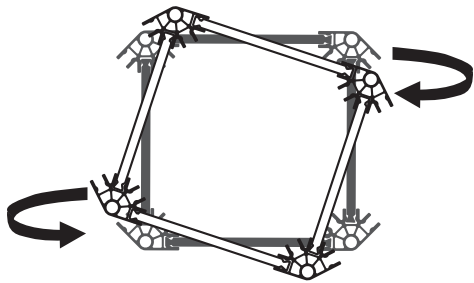

Torsion forces

- Ask each group to record whether or not their cube behaved as they had expected it to and their explanations for their observations. They should use the correct technical vocabulary in their notes and include drawings, using directional arrows to indicate **compression**  $\rightarrow \leftarrow$  and **tension**  $\leftarrow \rightarrow$

### EXPECTED OUTCOMES

Students should discover that a cube frame structure is able to support large loads when the structure is vertically loaded. The weight of the load acts through the vertical sides – along the long axis of the K'NEX rods (or **axially**). As demonstrated in Skill Builder #2, K'NEX Rods are strong when under compression and so the K'NEX cube is able to support quite large loads.

Other forces, however, cause the frame to distort. The weak points are at the fixed joints, which can snap open and break. The selection

of joint type to be used in large structures is very important and must take into account the effects of the different forces that act on it.

**IMPORTANT SAFETY NOTE:** *If the structure is twisted too much, the joints may snap open ejecting one or more connecting Rods from the structure. While this effect demonstrates a dramatic failure of the structure, students should be instructed not to exert too much force because of the potential hazard from the ejected Rods. Protective eyewear should be worn.*

### WHOLE CLASS

Write questions for discussion on the board and allow the class time to discuss their observations within their group.

For example:

- Did the structure behave as predicted? If not, why not?
- Why did you think the structure would behave in the way you predicted?
- How might you make your cubes into stronger structures?

### WORKING IN GROUPS 2-3

- Ask the students to modify their models by adding EITHER a gray Rod (for the red cube) or the yellow Rod (for the blue cube). They should be encouraged to test their structure after adding a Rod to one or more faces of the cube and then record their findings in their journal.

It is not possible for K'NEX Rods to be added to all of the faces of the cube – there is a limit to the number of places that the Connectors can interlock at one time.



SECTION I

# Skill Builder 5

## Teacher's Notes

### SECTION I

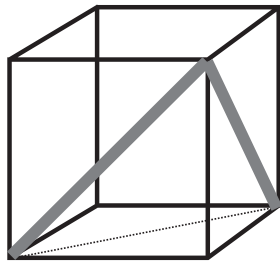

The solid lines show where 2 K'NEX diagonal members may be added to the structure. No connection points are available to insert a diagonal member in the plane shown by the broken line.

The faces with the added diagonal braces have been strengthened by triangulation. Other faces can still be easily distorted. Frame structures, therefore, make use of triangulation for increased strength and to prevent distortion.

### WHOLE CLASS

- Review how frame structures can be reinforced and strengthened by triangulation. Discuss how the addition of K'NEX Rods as diagonal members increased the rigidity of the K'NEX cube structure.
- Refer students to the K'NEX Real Bridge Building Instructions and/or built models of bridges with through-frame structures such as the Forth Rail Bridge, the Astoria Bridge, the roadway of the Golden Gate Bridge and the arch span of the Sydney Harbour Bridge; ask them to notice how triangulation is used to produce strong, rigid structures that span long distances.
- Provide factual background information by comparing the vital statistics of these bridges with the longest single span in Chesapeake Bay Bridge (K'NEX Real Bridge Building Instructions).

## 2: USING TENSION MEMBERS

### WORKING IN GROUPS OF 2-3

- Explain how large structures are subjected to **environmental forces**, such as wind, which can produce **torsion** effects in them.
- Ask students to consider the effects of high winds on structures such as the Astoria, the Golden Gate, The Dames Point and the Sydney Harbour bridges.
- Ask them to consider the effect of wind on structures with gaps between their members?

You can easily demonstrate the effect of wind by using an electric fan to blow over/move a small K'NEX structure or a cardboard box. Some of the bridge models with large surface areas, such as the Dames Point Bridge, may be seen to move under such conditions. You may also want to refer to Chapter 9 in Mario Salvadori's *The Art of Construction*, which outlines some simple experiments that can be undertaken in the classroom to demonstrate the effects of wind on structures.

Skill Builder #4 activities introduced students to the use of tension members to strengthen and reinforce frame structures.

- Ask each group to use string as tension members to make their structure more stable. Refer the students to Skill Builder #4 examples C, D and E if necessary.

### Example: Using tension members.

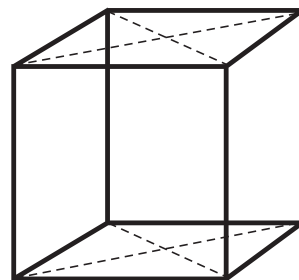

# Skill Builder 5

## Teacher's Notes

### Skill Builder 5B

#### Extending the Activity - Making long beam bridges

#### THE INVESTIGATION

1. To work in teams to construct a 70cm to 80cm bridge span, using a chain of cubes or rectangles.
2. The beam bridges made by any two teams will be of different depths or thickness.

#### THE PROCESS

#### WORKING IN PROJECT TEAMS OF 4-6

Time for construction: Approximately 15 minutes.

- Each project team should first be encouraged to plan how they will construct their beam bridge. They should consider the human resources they have available and how to use them effectively. Students could be introduced to the idea of developing a simple flow chart to identify the tasks and the order in which they must be completed.
- Questions to ask:
  1. How many K'NEX components will they need? They should use their previous experience of making cubes to estimate quantities.
  2. How will they plan and organize the construction of their beam bridge?  
What parts can be pre-assembled and used as sub-assembly units? For example, joining together yellow Connectors to make the bridge joints? Pre-assembly of cubes? Or if the team is large enough, can they form two teams of sub-contractors each making half a bridge?
  3. What is the specific job of each team member, including final assembly?
- Depending on available time, this activity could be separated into two parts. In the first part the beams are not strengthened and in the second part **triangulation** is used

to strengthen the structures to create, for example, a simple **Warren truss** construction.

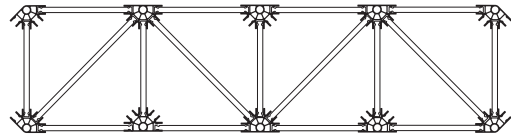

- Team A can only use the white Rod as their depth measure.
- Team B should use the yellow Rod as their depth measure. Team B's beam should be twice the depth of team A's beam.

Team A

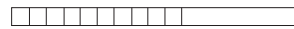

Team B



- Once each beam bridge is completed, it is loaded at its mid-point. The load bearing ability of each bridge can then be compared. The simplest test is to find the load at which one or both bridges start to sag or break.
- Before starting the test each team should be asked to predict the results of the test and the reasons for their prediction. For example, Team A's un-reinforced bridge may support up to 700gm before failure occurs, whereas the reinforced structure may support loads of around 1Kg.
- It may be useful for students to measure the load on the bridge by placing each end on a top loading/top pan balance. Each top pan balance acts as a bridge pier. The loading on each pier can be traced as the load moves from one side of the bridge to the other. This activity will demonstrate to students that the loading on each pier is greatest when directly over each one and at a minimum when in the middle of the bridge span. The maximum loading on the beam will be at its mid-point.



SECTION I

# Skill Builder 5

## Teacher's Notes

### SECTION I

**IMPORTANT SAFETY NOTE:** *On failure the joints may snap open ejecting one or more connecting Rods from the structure. While this effect demonstrates a dramatic failure of the structure, students should be instructed not to exert too much force because of the potential hazard from the ejected Rods. Protective eyewear should be worn at all times.*

### WHOLE CLASS

- The students should be given time to evaluate their own results and those of other teams. Members from each team should be asked to give a short presentation on their investigation and include explanations of their observations.
- This activity may be used to introduce or reinforce the concept of the **span/depth ratio** as used by structural engineers to estimate the depth of a bridge span for a given **working load**.
- From previous activities – Skill Builder #1 – students will be aware that short beams have a greater load bearing capability than long beams of the same depth. This activity extends the application of the concept to truss bridge constructions.

### Skill Builder 5C

Applying the Concept -  
Investigating a Real World Structure

The following activity may be carried out at this point or may be incorporated into one of two larger activities such as:

- **Section II: Case Study of a Bridge Design** and/or
- **Section III: Bridge Construction - An Exercise in Teamwork, Planning and Implementation**

### INTRODUCTION

- Working in groups of 4-6, students will construct a model of the Astoria Bridge. The Astoria Bridge is an example of a truss-cantilever construction.
- Students will be expected to apply skills learned from previous Skill Builder activities.
- Each team will construct, test and observe what happens to the structure when it is loaded at different points along its length.

### MATERIALS

- K'NEX Real Bridge Building set(s)
- Book 2 Building Instructions for the Astoria Bridge (duplicate copies of the instructions can be printed from files on the accompanying CD-ROM)

*Note: Two models of the Astoria Bridge can be made simultaneously from 1 K'NEX Real Bridge Building set.*

### ADDITIONAL RESOURCES

- Internet access for students to carry out research on their selected bridge.

### THE PROCESS

#### WORKING IN TEAMS OF 4-6

- Teams apply the planning and sub-assembly experience they gained in Skill Builder 5B to the construction of the large K'NEX bridge model.
- Once completed they should use the model to investigate, identify and answer the following:
  1. What were the structural engineering concepts used in the bridge design and how were they applied?
  2. How does the K'NEX bridge model behave when loaded in different positions?

# Skill Builder 5

## Teacher's Notes

3. What happens to the bridge structure when loaded?
  4. Does any part of the bridge structure move? How is movement minimized in the real bridge?
  5. How rigid is the bridge structure? Does it twist easily?
  6. How would you modify the K'NEX bridge design to prevent the structure twisting?
  7. Would you use the K'NEX model design to make a full-scale construction? Explain your reasons.
  8. How does the construction of your K'NEX bridge model compare with that of the real bridge? Use photographs obtained from the Internet and from the Building Instructions.
- Each member of the team should write his/her own report on the bridge design. The report should include a description of the practical investigations and how the behavior of the model differs from that of the real bridge.
  - As part of their record keeping, students could be asked to make scale drawings of their K'NEX Real Bridge model from direct measurements made on the actual model. If time permits, the drawings could include a plan as well as side and front elevations.
  - Students might carry out an Internet investigation on the Astoria Bridge using some of the links provided below. These offer some additional statistics and photographs with which to analyze its construction. Possible topics to investigate:
    1. What challenges of location faced the designer of the bridge and how were they overcome?
    2. What types of forces act on the bridge and how does the design takes them into account?
    3. Why was this particular type of bridge design chosen for this location?

4. Why is the main bridge span slightly arched and not straight? What does the arch add to the structural strength of the bridge?
5. What alternative designs were considered for this bridge site and why they were rejected?
6. In your opinion, is the bridge a successful structure? Why or why not?

Some useful Internet web sites for the Astoria Bridge:

This is a useful web site for the Astoria Bridge.

<http://www.oldoregon.com/visitor-info/entry/astoria-megler-bridge/>

You can obtain additional resources by entering Astoria Bridge – Oregon in a search engine.



### SECTION I

# Skill Builder 6

## Teacher's Notes

### Spanning Gaps - Beams or Arches?



#### SECTION I

#### INTRODUCTION

The concepts and activities outlined here continue the progression from those in Skill Builder #5 and introduce students to the effects of external forces on two bridge designs. In Skill Builder #6 students compare and contrast a simple beam bridge with an arch bridge. As in previous Skill Builder activities, technical vocabulary can be introduced and students have the opportunity to develop their Information Technology skills.

#### OBJECTIVES

Students will understand that:

- The practical length of a beam bridge is limited, but an arch structure is stronger and can be used to span greater distances.
- Simple beam bridges are subjected to bending forces due to tension and compression.
- The predominant force acting on an arch structure is compression.
- The physical characteristics of the site and the intended use, affects the design of a bridge.

#### MATERIALS

- K'NEX Real Bridge Building set(s)
- Building Instructions Booklet
- Rulers
- Slotted or other masses (10g-1000g)
- Sheets of white paper
- Additional copies of Building Instructions for the Chesapeake Bay Bridge and the Sydney Harbour Bridge models.
- Top pan balances (optional for Part 2)

#### VOCABULARY

*load, strength, stability, beam, arch, brace, diagonal, member, strut, tie, compression, tension, shear, torsion, triangulation, span, pier, guardrail, abutments, arch*

#### THE INVESTIGATION

This is in two parts:

##### 1. Beams and arches:

Students, working in small groups of 2-3, investigate the load bearing ability of two different bridge designs: (a) a simple beam and (b) an arch. Students will carry out a series of brief investigations, (20-30 minutes total time,) using a 500g load at the mid-point of each model bridge and measuring the amount of sag in the beam or arch. The simple beam bridge will be a modified version of one span of the K'NEX Chesapeake Bay Bridge. Introducing the arch concept will involve using a section of black decking from the set and experiencing the forces involved in the structure.

##### 2. Applying the concepts:

The second part, involving larger teams of 4 to 6 students, investigates how structural engineers have used the simple beam and arch concepts to make real bridges. Students will construct and test K'NEX models of the Chesapeake Bay Bridge and the Sydney Harbour Bridge. This investigation also provides opportunities for students to carry out research using an approved Internet search engine.

Total time: 1.5 - 2 hours



# Skill Builder 6

## Teacher's Notes

### PROCESS

#### 1. Beams and Arches

##### (a) A simple beam bridge

- Ask the students to recall their first attempts at constructing a bridge to span a gap. These attempts were probably not very successful as they sagged in the middle, often before a live load was placed on the structure. Review the ways that such structures can be strengthened: using triangulation to create truss structures, for example.
- Explain that in this Skill Builder activity they will first investigate an alternative way of strengthening a long simple beam bridge. Ask them to look at the photo of the Chesapeake Bay Bridge-Tunnel shown on P. 4 of Book 1 Building Instructions. Ask what they notice about the characteristic features of the bridge. How long is this bridge? Would an unsupported structure be able to span this distance?
- Review how engineers have used piers to support the structure – in effect they have built a very large number of simple beam bridges and connected them to create a continuous span.

##### WORKING IN GROUPS OF 4-6

- Half the team will build 2 sections of the Chesapeake Bay Bridge while the other half will build the equivalent length, but without the extra set of piers.
- Students will then place their model beam bridges so that the piers are resting on sheets of paper. They should draw the footprint of the piers on the paper.
- Ask them to add loads, incrementally, to their bridges and notice what happens to the decking and to the position of the piers.

- They should compare the maximum load, amount of sag in the beam and amount of splaying of the piers (if any).
- The students should be encouraged to record their observations through the use of labeled drawings and directional arrows, where appropriate. Notes should be included using the correct technical vocabulary.

### WHOLE CLASS

Discuss the effect of increasing the length, without additional support, on the load bearing ability of a simple beam bridge. Raise the issue of the limitations that a simple beam bridge presents when spanning wider barriers.

##### (b) An arch

##### WORKING IN GROUPS OF 2-3

- For this activity each group will need 1 piece of black decking from the K'NEX Real Bridge Building set and access to weights. Explain that they will compare the load bearing capacity of a simple beam and an arch. They will also experience the forces acting on the arch as they manipulate the length of decking.
- Ask them to gently bend the piece of decking into an arch shape. They should place their hands on the desktop as they hold the shape in position and then relax their hold slightly. Ask:
  - What do they feel?
  - What happens to the arch once the pressure from their hands is released?They should feel the two ends of the arch pushing outwards against their hands. To maintain the arch shape they have to push inwards. Students should take turns trying this activity.
- To compare the load bearing capacity of a simple beam with an arch, ask the students to carefully add a 500g weight to the mid-point



## SECTION I

# Skill Builder 6

## Teacher's Notes

of the arched roadway. One student can hold the ends of the arch in place, while a second student adds the load. Ask them:

- To record any evidence of the arch sagging or showing signs of failure.
- What happens to the arms of the arch as the load is increased?
- What must they do to enable the arch to keep its shape?
- What will happen to the arch if they removed their hands?
- Can the arch support a 1Kg load?
- The students should then undertake a similar investigation using the roadway as a beam and compare their results. It can be supported at either end on books or students can use the piers they made in the first part of the activity. They should be asked to load the beam at its mid-point with a 500g weight and record their observations. What is the maximum load the beam can support?

Once this part of their investigation is completed, groups should be given time to record their results and explain their findings.

### WHOLE CLASS

- Discuss the results of the two different bridge investigations.
- This may be a good point to review or introduce the different types of forces acting in and on beam and arch bridges, and the advantages and disadvantages of each design. Alternatively, direct the students to the **Readers #2, 3 and 4.**
- Facts to highlight:
  - Beam bridges are subjected to the forces of tension and compression.**
  - The ability of a beam bridge to resist bending forces depends on the stiffness of the material from which it is made.**
  - The predominant force in an arch is compression.**

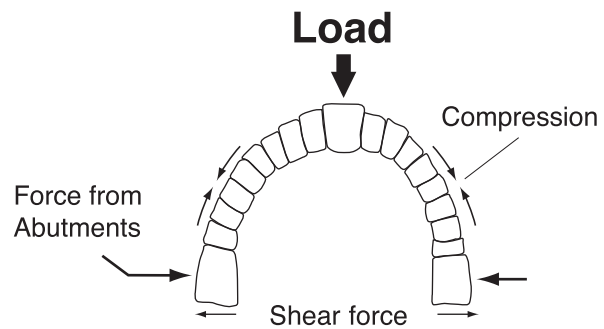
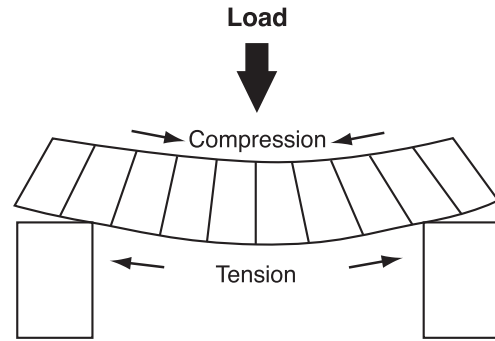

- When designing a bridge or structure, engineers try to eliminate a combination of compression and tension acting together in any structural member as this can lead to it bending. The result of a member bending could be the whole structure fails.
- Materials are strong or weak when acted on by tensile stresses or compressive stresses. By designing a structure so that members are only under compression (struts) or tension (ties), bending effects can be greatly reduced.
- Arch bridges are stronger than beam bridges because the whole structure is under compression. External load forces acting on the arch are dissipated along the curved arms towards its ends and from there into the supporting sides. The reaction of the supporting sides is to push back against the

# Skill Builder 6

## Teacher's Notes

arch creating a resistance that is transferred along its length. All parts of the arch bridge are therefore under compression – from the weight of the bridge deck pushing out along the curve of the arch and from the resistance of the sides pushing back. Tension, by comparison is a very minor force in an arch, even on its underside.

- Early arch bridges were made from stone – a material that is strong under compression. Many Roman arch structures are still standing today and were made without mortar – a testimony to the inherent structural strength of the arch. The only things holding the blocks together are the compression forces acting in the structure and the ability of stone to resist compression. Arch bridges, however, need strong supporting structures – **abutments** – to keep the sides in place and so prevent the arch from collapsing.
- Remind the students of what occurred when they removed their hands from the sides of the arch in their initial investigation (P. 63). Their hands had been acting as abutments. Questions to ask:
  - Where and at what types of locations/sites are beam and arch bridges used?
  - Why do the designs suit their particular situations?
- Refer the students to the examples in the K'NEX Real Bridge Building set – the Chesapeake Bay Bridge-Tunnel and the Sydney Harbour Bridge.

The following activity may be undertaken at this point or may be incorporated into one of two larger activities such as:

### **Section II: Case Study of A Bridge Design**

and/or

### **Section III: Bridge Construction – An Exercise in Teamwork, Planning and Implementation**

## **PART 2: APPLYING THE CONCEPT - INVESTIGATING REAL WORLD STRUCTURES**

### **INTRODUCTION**

- Teams of up to 6 students construct a K'NEX Bridge model of either the Chesapeake Bay Bridge or the Sydney Harbour Bridge. They will be expected to apply skills learned from previous Skill Builder activities.
- Students should be made aware that although the total length of the Chesapeake Bay Bridge-Tunnel is approximately 24,140m (15 miles), the longest single bridge span is only 31m (102 ft). By comparison the single span of the Sydney Harbour Bridge is 504m long (1663 ft).
- Two bridge models can be made simultaneously from a K'NEX Real Bridge Building set. Once teams have completed investigating their own bridge, they could change places with another team and investigate the other bridge design.

### **OBJECTIVES**

For students to learn:

- How location, site and intended use affects the design of a bridge.
- How arches are used in bridge designs.
- The forces that act on beam and arch structures.

### **ADDITIONAL RESOURCES**

- Internet access for students to carry out research on their selected bridge.



## **SECTION I**

# Skill Builder 6

## Teacher's Notes



### SECTION I

#### THE INVESTIGATION

- Each student team will construct, test and observe what happens to the structure when it is loaded at different points along its length and identify the forces that act on it.
- They will also research:
  - The structural engineering concepts used in the design and how they were applied.
  - How the design has been influenced by the physical characteristics of the site.

#### THE PROCESS

##### WORKING IN TEAMS OF 4-6

- Teams should spend time considering the most efficient way to construct the bridge and to locate the background information needed for their investigation. They should also discuss how they might measure the load on the bridge and how to record movement in the structure of the bridge when it is loaded.
- When investigating how their K'NEX bridge model behaves when loaded in different positions, it may be useful for students to measure the load on the bridge by placing each pier on a top pan balance. The loading on each pier can be traced as the load moves from one side of the bridge to the other. This activity will demonstrate to students that the loading on each pier is greatest when directly over each one and least when in the middle of the bridge span. The maximum loading on the beam will be at its mid-point.
- Students should be encouraged to determine the maximum load each bridge can hold on a single span. They should note where and how any failure in the structure occurs.
- They should consider what forces are acting on their model when it is under load and how the bridge is affected.

- Does any part of the bridge structure move? What causes this movement in the structure? How is any similar movement prevented in the real bridge?

*K'NEX models are not anchored in any way and so movement is likely to occur in the bridge piers or, in the case of the arch, where the abutments would normally be. The strength of any arch structure is found in the reaction of the abutments to the outward horizontal forces produced by the arch. Refer students to the web sites listed below to find out how construction of the real bridges reduced structural movement.*

- As part of their record keeping, students could be asked to make scale drawings of their K'NEX Real Bridge from direct measurements made on the actual model. If time permits, the drawings could include a plan together with side and front elevations.
- The following questions could be asked of the teams:
  - Would you use the K'NEX model design to make a full-scale construction? Explain your reasons.
  - Compare the construction of your K'NEX bridge model with the real bridge. Use photographs obtained from approved Internet web sites.
- Team members might carry out an Internet investigation on the two named bridges using some of the links below. These websites provide additional facts, statistics and photographs with which to analyze the bridge construction. Possible areas to research include:
  - Design challenges caused by the physical conditions of the site and how they were solved.
  - The types of forces acting on the bridge and how the design accounts for them.
  - The challenges facing the construction team and how they were solved.

# Skill Builder 6

## Teacher's Notes

- Why this particular type of bridge design was chosen for this location.
- The alternative designs that were considered and why they were rejected.
- If, in their opinion, the bridge is a successful structure. They should be prepared to justify their answers.

Information on the Chesapeake Bay Bridge-Tunnel can be found at:

<http://www.cbbt.com/history.html>

*This site outlines the history of the Chesapeake Bay Bridge-Tunnel and shows photographs of its construction.*

[http://www.pbs.org/wgbh/buildingbig/wonder/structure/chesapeake\\_bay\\_brdg.html](http://www.pbs.org/wgbh/buildingbig/wonder/structure/chesapeake_bay_brdg.html)

*Useful background information and statistics.*

<http://www.roadstothefuture.com/CBBT.html>

*Helpful information, links to other sites and photographs of the bridge.*

Information of the Sydney Harbour Bridge can be found by visiting the following sites:

<http://www.gids.nl/sydney/info.html>

<http://www.austehc.unimelb.edu.au/tia/426.html>

*Both sites give some interesting information about the construction of the bridge.*

<http://www.bridgepros.com/projects/SydneyHarbour/SydneyHarbour.htm> *This site also provides links to similar arch bridges in other parts of the world.*

These sites were obtained from search engines using key words such as, "Chesapeake Bay Bridge Tunnel."

### WHOLE CLASS

Review the students' findings on:

- How the two model bridges behaved when loaded.
- How each real bridge design was affected by the loads they must support, the distances they have to span and the nature of the bridges' locations.

### ASSESSMENT

- Each member of the team should write a report on the two bridge designs to include the group's practical investigations and how the behavior of each model differs from their real world counterparts.



## SECTION I

# Skill Builder 7

## Teacher's Notes

### Investigating Cantilevers

#### INTRODUCTION

The investigations carried out so far have involved simple beams. Beams are structural members that are subject to bending forces, so that a simple beam supported at both ends tends to bend in the middle.

A **cantilever** is a beam that is supported at one end only. An example that most students can visualize at work is that of a diving board. A board with no load remains straight, but as the diver moves to the free end of a springboard it will bend downward.

The cantilever principle is used in bridge construction as well as in a wide range of other structures, including sports stadium roofs, balconies, carports, aircraft wings, shelves, hinged doors and castle drawbridges. One of the main limitations in making arched bridges is that both sides of the arch act as cantilevers until the span is completed. You may want students to research how cantilevers influenced the construction of the Sydney Harbour Bridge. Cantilevers can also be seen in nature – tree branches or human arms and legs, for example.

Two types of basic cantilevers are used in bridge designs:

1: **Hinged cantilever:** Tower Bridge. The beam is attached to a support by a hinge joint, which allows the beam to rotate around the hinge.

2: **Fixed cantilever:** Firth of Forth Rail Bridge, Astoria Bridge and cable-stayed bridges such as The Dames Point Bridge. The beam is fixed to its support in such a way that it is unable to rotate. A load placed on the free end of the beam tries to make the beam rotate in the direction of the applied force, but because the fixed end (or **root**) cannot rotate, the beam **bends** downwards instead.

The forces exerted on the root are dependant on the size of the load (measured in Newtons) and the distance the load is applied from the **root** (measured in meters). This **turning force** is called the **bending moment** and can be calculated as follows:

$$\begin{array}{l} \text{The bending} \\ \text{moment} \\ \text{(Newton meters)} \end{array} = \begin{array}{l} \text{Force} \\ \text{(Newtons)} \end{array} \times \begin{array}{l} \text{Distance} \\ \text{(meters)} \end{array}$$

As in previous Skill Builder activities, there are opportunities to introduce technical vocabulary and for students to develop their Information Technology skills using Internet search engines, to obtain, evaluate and collate information for inclusion in a report.

#### OBJECTIVES

For students to learn:

- Cantilever beam bridges are subjected to bending forces due to tension and compression.
- In cantilevers, tensile forces act on the upper surface and compressive forces on the lower surface.
- How cantilevers are used in the design of bridges.



# Skill Builder 7

## Teacher's Notes

### MATERIALS

- K'NEX Real Bridge Building set(s)
- Building Instructions Booklet - you will need additional copies printed from the accompanying CD-ROM
- Slotted masses (100g)
- Spring scales
- String
- Rulers
- Top pan balances (optional)

### VOCABULARY

*cantilever, fixed and hinged cantilevers, root, bending moment, load, strength, stability, beam, brace, diagonal, member, strut, tie, compression, tension*

### THE INVESTIGATION

This is in two parts:

#### 1. Investigating a cantilever

The cantilever will be made by modifying the bridge raising mechanism from the K'NEX Tower Bridge model in Book 1, Page 41: Steps 24 – 28. One modification in Step 24 is to replace the white Rods with gray Rods. This modification will help to multiply the forces acting on the structure. Two mechanisms can be made from each bridge model so that 4 groups of students (2-3) can work from 1 Real Bridge Building set simultaneously.

Time: 30-40 minutes.

#### 2. Investigating how structural engineers have used cantilevers to make real bridges

This will involve teams of 4-6 students constructing and testing K'NEX bridge models that use the cantilever concept in their design. This investigation also provides opportunities for students to carry out research using an approved Internet search engine such as Google.

Total time: 1.5 – 2 hours.

### PART 1:

### INVESTIGATING A CANTILEVER

### THE PROCESS

### WHOLE CLASS

- Introduce the class to the concept of a cantilever in action by asking them to hold the end of a length of black decking from the K'NEX Real Bridge Building set (or a ruler) between their thumb and forefingers. Holding it firmly with some pressure will make sure that the 'beam' remains level, but as soon as they release the pressure it will start to bend downwards.

- Adding a weight at the free end will help them understand how even more force must be applied to keep the beam level.

- Suggest they place the beam on an upright book so that most of it is unsupported and then find a way to make it balance. They could then add a weight at the free end and then try to balance the beam again.

- Explain that this is the principle of the cantilever – the beam can extend unsupported for a considerable distance so long as at the opposite end there is a means to counterbalance it.

- Explain that they will build a model of a hinged cantilever and test its load bearing ability by observing the **deflection** or bend in the beam caused by placing a 100g load at its free end. They will then measure the force required to raise the beam back to a horizontal position by pulling back on the blue lever mechanism of the model.

Students can EITHER observe “cause and effect” and “feel” the forces needed OR make measurements of the deflection at the end of the beam and the forces, using a spring scale.

- Explain that they will investigate how longer lengths of the cantilever beam behave.



## SECTION I

# Skill Builder 7

## Teacher's Notes



### SECTION I

Increasing the length of the cantilever can be accomplished by inserting additional blue Rods and yellow Connectors into the beam at the hinged end.

- You may want to discuss some of the technical vocabulary at this point, such as **free end**, **root**, **bending moment/turning force** and introduce the mathematical equation used to derive the bending moment (see above).
- The starting point for loading the cantilever beam should be as close to the hinge (root) as possible. You may want to make a drawing on the board similar to the one shown below.  
Observations to be made are:
  - Length of cantilever beam (L)
  - Deflection at the free end of the beam (D)
  - Force required to return the main part of the beam to a horizontal position (F)
  - The effect of the cantilever beam on the vertical support. (S)

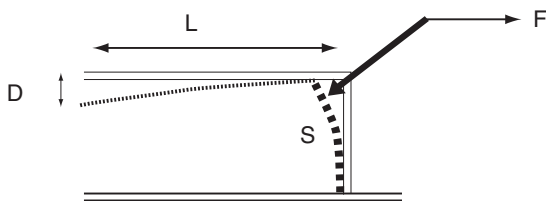

### WORKING IN GROUPS OF 2-3

- Allow students a few moments to familiarize themselves with the building instructions for the bridge raising mechanism of the Tower Bridge model, the changes to be made and what they have to do.
- Once built, provide time for them to investigate the model before starting their investigations. They can discuss and comment on how they think the cantilever will behave.

For example:

- What do they think might happen to the cantilever beam as its length increases?
- What will be the effect on the vertical support?
- What is the longest length of cantilever beam (not the vertical support) that can support a 100g load without bending?
- How will they measure the amount of deflection of the cantilever beam and how will they record and present their results to make them easier to interpret?
- What position of the load maximizes the stresses on the cantilever beam?
- Did their bridge behave as they expected?
- Groups should be given time to record their results and explanations of their findings, using the correct technical vocabulary, before proceeding to the next part of the activity. Drawings of models should also be made – these should include descriptions of the forces acting on the main parts of the structure.

### WHOLE CLASS

- Allow time for the class to discuss their findings and provide explanations of their observations.
- Ask how a long cantilever beam can be supported to make a stronger structure. What techniques have they used before to strengthen weak structures and how can they be applied here?

### EXPECTED OUTCOMES

- Students might be expected to find that as the length of the cantilever beam increases, the bending moment also increases. The maximum stresses occur in a cantilever beam when a live load is placed at its free end and they are minimal when the load is close to the hinge or **root**.



# Skill Builder 7

## Teacher's Notes



### SECTION I

Compression and tension in a cantilever beam can be demonstrated using a length of sponge graduated vertically into equal spaces. As the sponge cantilever bends, the segments on the top become wider indicating tension and those on the bottom decrease in size indicating compression. For example:

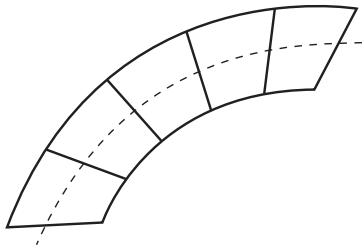

- The weight of the beam itself (the dead load) also has a significant impact on cantilever bridge design. The K'NEX model should demonstrate that the vertical support is also subjected to bending forces.

### DEMONSTRATION

- Discuss and demonstrate how a cantilever beam can be supported either by pushing up from below and/or pulling up from above.
- Each group should then try for themselves.

### WORKING IN GROUPS OF 2-3

For example:

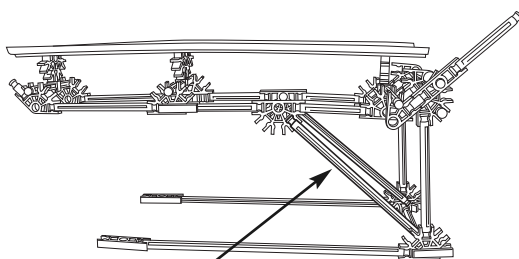

Add red Rod here

Use the extended beam length (made by adding blue Rods and white Connectors) and incorporate a red Rod as a **strut**. The upper part of the Rod can be connected to a yellow Connector, while the lower end can simply rest in the angle.

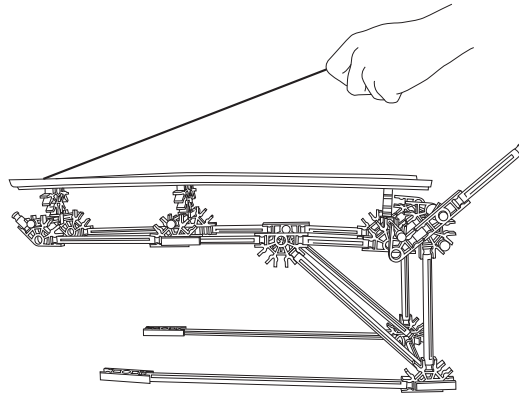

Using string as a **tension member** or **tie**.

### WHOLE CLASS

- Two discussion points can be raised.
  1. The need for a tall tower to give enough height for a tension member to be used.
  2. A long cantilever puts bending forces on the vertical support. How can this be avoided?
- You may wish to review the need for balanced forces within structures and how this might be achieved.

For example:

By joining two structures so the forces are equal and opposite:

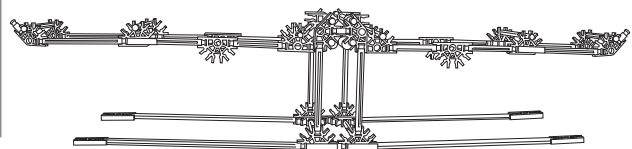

# Skill Builder 7

## Teacher's Notes

This arrangement balances the bending forces on the vertical support. Two models can be simply joined together using Connectors.

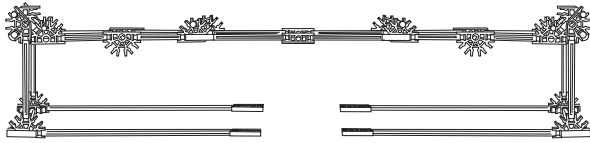

Here the two arms push against each other and are similar to the two halves of an arch.

### WORKING IN GROUPS OF 4-6

- Ask 2 groups of students to combine and use both models to investigate the situations outlined above.
- At the completion of this part of their investigation, groups should be given time to record their results and explanations of their findings. Drawings of models should include descriptions of the forces acting on the main parts of the structure.

The following activity may be undertaken at this point, or may be incorporated into one of two larger activities such as:

**Section II: Case Study of a Bridge Design**  
and/or

**Section III: Bridge Construction –  
An Exercise in Teamwork, Planning and  
Implementation**

## PART 2: APPLYING THE CONCEPT - INVESTIGATING REAL WORLD STRUCTURES

### INTRODUCTION

- Teams of up to 6 students construct a K'NEX Bridge model of either the Firth of Forth Rail Bridge or the Dames Point Bridge. They will be expected to apply skills learned from previous Skill Builder activities.

*NOTE: Although the Dames Point Bridge is classified as a cable-stayed bridge, its design contains both cantilever and suspension bridge elements.*

- Two K'NEX Real Bridges can be made simultaneously from a K'NEX Real Bridge Building set. Once a team has completed investigating their own bridge, they could exchange places and investigate the other bridge design.

### OBJECTIVES

For students to learn:

- How location, site and intended use affects the design of a bridge.
- How cantilevers are used in bridge design.

### ADDITIONAL RESOURCES

Access to the Internet to carry out research on each group's selected bridge.

### THE INVESTIGATION

- Each student team will construct, test and observe what happens to the structure when it is loaded at different points along its length and identify the forces that act on it.

# Skill Builder 7

## Teacher's Notes

- They will also research:
  - The structural engineering concepts used in the design and how they were applied.
  - How the design has been influenced by the physical characteristics of the site.

### THE PROCESS

#### WORKING IN GROUPS OF 4-6

- Combine 2 groups to act as a single team to construct a K'NEX bridge model and then to investigate and identify, for example:
    - How their K'NEX Bridge model behaves when loaded in different positions.
    - Suggest that before teams join the halves of the bridge together, they should test what happens when a small load is placed on one side.
    - What forces are acting on their model when it is under load and how do they affect it? Do parts of the model move? How are these potentially disastrous problems solved in the real bridge structure?
  - In their investigation of the Dames Point Bridge, student teams might replace some of the longer cables with string or long elastic bands to help visualize the tension that occurs when the structure is loaded.
  - In the completed bridge, the outer cables could be disconnected to see what happens to the structure when a large load is placed in the middle of the main span. The bridge will in fact collapse in on itself because the forces are no longer balanced.
  - As part of their record keeping, students could be asked to make scale drawings of their K'NEX Real Bridge from direct measurements made on the actual model. If time permits, the drawings could include a plan as well as side and front elevations.
- In their investigation of the Firth of Forth Rail Bridge students should be asked to identify the main structural members that are under compression and tension. What happens if members are removed from A or B?

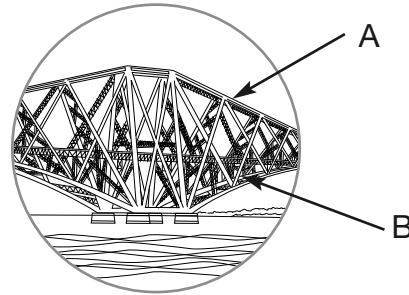

### SECTION I

# Skill Builder 7

## Teacher's Notes



### SECTION I

- You may want students to provide answers to the following:
  - What is the maximum load each bridge can hold on a single span? Note where and how any failure in the structure occurs.
  - Would you use the K'NEX model design to make a full-scale construction? Explain your reasons.
  - Compare the construction of your K'NEX bridge model with the real bridge. Use photographs obtained from approved Internet web sites.
- Photographs of a cantilever bridge collapse, the Koror-Babeldaob Bridge may be seen on: <http://www.ketchum.org/bridgecollapse.html>.
- Students might carry out an Internet investigation on the two named bridges using some of the links below. These provide additional facts, statistics and photographs with which to analyze its construction. Some topics to research:
  - Design challenges caused by the physical conditions of the site and how they were solved.
  - The types of forces acting on the bridge and how the design takes them into account.
  - Why this particular type of bridge design was chosen for this location.
  - Both bridges are like giant seesaws. How does the bridge design take into account loads moving across them?
  - The challenges facing the bridge construction team and how they were solved.
  - Why is the main bridge span of the Dames Point Bridge slightly arched and not straight? What does the arch add to the structural strength of the bridge?

- The alternative designs that were considered and why they were rejected;
- If, in their opinion, the bridge is a successful structure. They should be prepared to justify their opinions.

The following general Internet web sites are useful for student research and photographs.

[www.howstuffworks.com](http://www.howstuffworks.com)

[www.brantacan.co.uk](http://www.brantacan.co.uk)

<http://encyclopedia.thefreedictionary.com/Cable-stayed%20bridge>

Firth of Forth Rail Bridge web sites:

[http://www.pbs.org/wgbh/buildingbig/wonder/structure/firth\\_of\\_forth.html](http://www.pbs.org/wgbh/buildingbig/wonder/structure/firth_of_forth.html)

<http://www.pre-engineering.com/resources/forth/forthbridge.htm>

Dames Point Bridge web sites:

<http://www.bridgepros.com/projects/DamesPoint/DamesPoint.htm>

### WHOLE CLASS

Review the students' findings on:

- How the two bridges behaved when loaded.
- The way in which each bridge design was affected by the loads they must support, the distances they have to span and the nature of their locations.

### ASSESSMENT

- Each student should write a personal report on the bridge designs that includes the group's practical investigations and how the behavior of each model differs from their real world counterparts.

# Skill Builder 8

## Teacher's Notes

### Investigating Suspension Bridges

#### INTRODUCTION

In this Skill Builder students are asked to investigate the technology of suspension bridges. This will be the culmination of their exploration into the ways in which engineers have overcome the problem of spanning wider and wider barriers.

The activities also present opportunities for students to continue developing their technical vocabulary, identifying and solving simple problems, keeping journal notes and writing reports. They will also be expected to expand their Information Technology skills through the use of word processing and/or desk top publishing, digital cameras to help record information otherwise difficult to save, the Internet for research, and presentation software for report writing.

#### OBJECTIVES

For students to learn:

- Suspension bridges are subject to compression and tension forces.
- Towers must be subjected to axial compression, cables and hangers to tension.
- An imbalance of tension and compression in a structural member causes bending.
- Simple problem solving skills.

#### MATERIALS

- K'NEX Real Bridge Building set(s)
- Building Instructions
- Scissors

- Additional string for hangers (*NOTE: String is available in the K'NEX Real Bridge Building set but should not be cut.*)
- Small masses (200g – 500g)
- Spring scale (optional)

#### VOCABULARY

*Simply supported beam bridge, span, gap, cable, hanger, tower, compression, tension, bending, dead load, live load, compressive stress, tensile stress, front elevation, side elevation*

#### THE INVESTIGATION

This is in two parts:

##### 1. Investigating a simple suspension bridge model:

In this investigation students work in teams of 4-6, to make and investigate a simple suspension bridge model.

They will review what happens to a long, simply supported beam bridge and how the suspension bridge design helps solve some of the problems associated with making long beams rigid. This will involve them comparing the solution developed by the engineers responsible for the design of the Chesapeake Bay Bridge-Tunnel with that developed for a suspension bridge such as the Golden Gate Bridge.

Time: 45 minutes

##### 2. Investigating how structural engineers have solved some of the problems identified in Part 1 through the examination of a real world suspension bridge:

Continuing to work as part of a larger group, students investigate how structural



SECTION I

# Skill Builder 8

## Teacher's Notes



### SECTION I

engineers have solved some of the problems identified in the first part of their Skill Builder activity. They will continue to construct and then test their K'NEX Real Bridge model of the Golden Gate suspension bridge. This activity also provides opportunities for students to carry out research using an approved Internet search engine.

Time: 1.5 hours

### PART 1: INVESTIGATING A SIMPLE SUSPENSION BRIDGE THE PROCESS

#### WHOLE CLASS

- Review the different types of technologies that have been used to span wider and wider barriers – piers, trusses, arches, cantilevers. Explain that the students will investigate the suspension bridge, which is essentially a beam bridge with a large amount of additional support. This support allows suspension bridges to span barriers of more than 3000 meters, compared to the simple beam bridge with its maximum span of 100 meters.
- Explain that they will begin by creating a simple model of a suspension bridge. They will follow the Building Instructions for the towers of the Golden Gate Bridge (Book 2, Pages 35-40: Steps 1-14) with a minor modification. They will also be required to construct a simple beam for the bridge. Any length of Rod may be used to achieve the length of 120cm, but it is recommended that the width of the beam is one blue Rod. Yellow Connectors can be used for joining the beam components.
- **Tower Modification:** In Step 7 a green Rod should be inserted on either side of the uppermost yellow Connector. Then another yellow Connector is added on either side so that there are 3 yellow Connectors in a row, joined by green Rods. The beam can then be

attached to the Tower by passing the ends of Rods forming the beam through the holes in the yellow Connectors. Some black Clips can be added to keep the Rods in place.

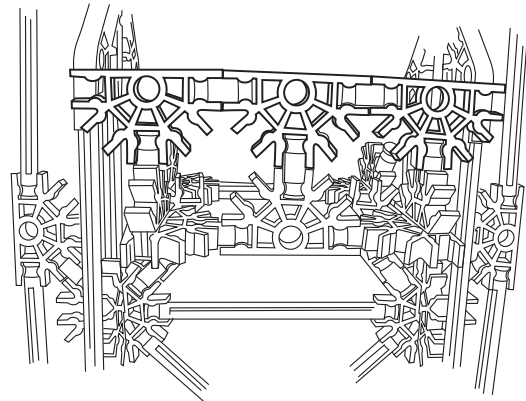

#### WORKING IN GROUPS 4-6

- Allow the students a few minutes to familiarize themselves with their task and to plan how they will make their model.

Suggested sub-assemblies for a group of 5 students:

Steps 1-5 x 2;

Steps 6-7 (with modification) x 2

Steps 8-11 x 2

Steps 12-14 x 2

Beam x 1

- Constructing the bridge – groups should ask themselves the following:
  - Who will make the towers?
  - Who will make the beam?
  - Does everyone in the group understand what they are expected to do?
  - How many K'NEX components will be needed to make a beam 120cm long?
- The 120cm beam is intended to simulate the long single spans used in suspension bridge design.

# Skill Builder 8

## Teacher's Notes

- Students work in their teams to investigate the forces that must be accounted for when designing suspension bridges. First, they will attach their beam to the towers, making use of the modification to the towers noted above, and then notice what happens when a load is added to this long, simply supported beam.
- Ask them to consider how they might overcome the problems they observe. Would a cable-stayed solution work for a very long beam bridge?
- Students may have had experience of cable-stayed bridge design. This simple activity is also intended to demonstrate that over such a long span, the cable-stayed solution is not a practical option and there are limitations on the use of that design for very long single spans.
- Ask:
  - Is simply attaching a cable to the tops of the towers and suspending the beam from it the solution?
  - What do the students think will happen?
  - Try it and see what occurs.
  - What alternative designs can the students suggest?
- Once this stage of construction is complete, groups should be given time to discuss the problems they encountered with their structure and then record their observations, with explanations. A digital camera may be useful to help students record information that is otherwise difficult to retain.

### EXPECTED OUTCOMES

- The students will find that the beam will continue to bend as before but with the added effect of the towers being pulled inwards.

- The towers are effectively behaving like **vertical cantilevers** and are being subjected to considerable bending forces, as is the beam.
- You may wish to discuss how structural engineers try to avoid the weakening effects of bending (when a structural member may be subjected to excessive tension and compression forces).
- Engineers try to design structures in which the **compressive and tensile stresses** that act on a structure are focused along lines of strength. For example, in beams and columns – **axial compressive force** and in cables – **tensile compressive forces**.
- Suspending the bridge:  
In this part of the activity, the student teams create a simple suspension bridge. They should use the string from the K'NEX Real Bridge Building set as the **main cable** and other pieces of non-K'NEX string can be cut to length as the **hangers**.
- Even when supported by a single hanger at its mid-point, the beam halves may still show a small deflection, with or without a small load.
- Additional hangers will be needed to fully support the beam along its length. Adding more hangers to the bridge makes the beam increasingly **rigid**.
- By pulling on both ends of the main cable, students can experience the forces needed to support the **dead load** of the bridge and any **live load** it is carrying.
- In addition, they should also note the need for the main cables to be strongly anchored. In their model, they perform the role of the anchorages, but how is this accomplished on a real world suspension bridge?
- Ask what might happen to the Golden Gate Bridge if one of the main cables broke?



## SECTION I

# Skill Builder 8

## Teacher's Notes



### SECTION I

- Students should also note the towers do not bend. They should be able to identify the **compressive** and **tensile** stresses acting on the cables and towers and explain how the materials from which they are made behave when subjected to these stresses.
- At the completion of this part of their investigation, groups should be given time to complete the recording of their results and their explanations before proceeding to the next part of the activity. A digital camera may be useful to help students record information.

#### WHOLE CLASS

- Discuss the results of their investigations and what they have learned about suspension bridges. You may want to raise some of the following points:
  - Where and in what types of locations are suspension bridges used?
  - Why does this bridge design suit these particular locations?
  - What are the advantages and disadvantages of suspension bridges? (For example: the effects of environmental loads.)
  - Compare the advantages and disadvantages of cantilever and suspension bridge designs.

The following activity may be undertaken at this point or may be incorporated into one of two larger activities such as:

**Section II: Case Study of a Bridge Design**  
and/or

**Section III: Bridge Construction –  
An Exercise in Teamwork, Planning and  
Implementation**

## PART 2: APPLYING THE CONCEPT - INVESTIGATING REAL WORLD STRUCTURES

### INTRODUCTION

- In this activity the teams complete and then investigate their model of the Golden Gate Bridge, applying skills learned from previous Skill Builder activities.
- Two K'NEX Real Bridge models can be made simultaneously from the one set. If only one K'NEX Real Bridge Building set is available, two groups of 4-6 students each may be involved in this activity, while other students might carry out a research project on the Golden Gate and other suspension bridge designs. On completion of each activity the two groups can change roles, with the Internet group making use of the completed bridge model.

### OBJECTIVES

For students to learn:

- How the location/site and the intended use of the bridge influences its design.
- The key features of a suspension bridge design and how the bridge design takes into account the forces that act on it.

### MATERIALS

- K'NEX Real Bridge Building set(s)
- Copies of the Building Instructions: Book 2 (available on the accompanying CD-ROM)
- Slotted masses (10g-1000g)
- Access to the Internet to carry out selective research on suspension bridges



# Skill Builder 8

## Teacher's Notes

### THE INVESTIGATION

- Students will construct, test and observe what happens to their structure when it is loaded at different points along its length.

### THE PROCESS

#### WORKING IN GROUPS OF 4-6

- Each group should continue building the model of the Golden Gate Bridge from Step 15. They should remove the parts they used to modify the towers in the earlier investigation.
- Suggested investigations for students to undertake once the bridge construction is completed:
  1. What are the structural concepts used in this bridge design and how are they applied?
  2. How did the location of the bridge influence its design?
  3. How does their K'NEX bridge model behave when loaded in different positions? (Remove the components added in Steps 21 on Page 43 and Step 30 on Page 46 of the Building Instructions when testing the bridge).
  4. What happens to the towers when the bridge is loaded at its central point once the supporting structures are removed (Steps 21 and 30)?
  5. What forces are acting on the bridge when it is under load and how do they affect it?
  6. Do parts of the model move? How are these potentially disastrous problems solved in the real bridge structure?
  7. What is the maximum load the bridge can support on its main span? Note where and how any failure occurs.
  8. If their suspension bridge is anchored more effectively will its load bearing ability be affected?

9. Would the students use their K'NEX bridge model design to make a full-scale construction? Ask them to explain their reasons.

- It may be useful for students to measure the load on the bridge by placing each tower on a top pan balance and to trace the loading on each tower as the load moves from one side of the bridge to the other. This investigation will help demonstrate to the students how the loading on a bridge is not equally distributed - it is greatest on each tower when directly over each one, and at a minimum when in the middle of the span. The maximum loading on the beam, however, will occur at its mid-point.

*Notes about the K'NEX model bridge:*

- *The towers in the K'NEX Golden Gate Bridge model are in fact held together - Steps 21 and 30 in the Building Instructions. This does not happen in real suspension bridges. The role of these parts is to stabilize the model's structure when under load. Students could be asked to comment on how the towers are stabilized in reality. What stops their bases from moving?*
- *When loaded at the mid-point of the central span, the two towers will bend as in the original investigation. What would they have to do to counteract this effect in their model? How is this solved in the real bridge design? Refer students to:*  
**<http://www.brantacan.co.uk/bridgedefs.htm#Susp>** for a diagram of a suspension bridge anchorage design.
- As part of their record keeping, students could be asked to make scale drawings of their K'NEX Real Bridge using measurements taken directly from their model.
- Each member of the team should write a report on the Golden Gate Bridge design. It should include their practical investigations and how the behavior of their bridge model compares with that of the real bridge.



## SECTION I

# Skill Builder 8

## Teacher's Notes



### SECTION I

#### INTERNET RESEARCH

Students should be asked to carry out research on at least **two different named** suspension bridges. They could be provided with the links cited below to obtain additional facts, statistics and photographs for inclusion in their reports.

Some possible areas of research:

- The design challenges caused by the physical conditions of the site and how they were solved.
- The environmental forces that act on suspension bridges and how these were taken into consideration in the construction of the selected bridge.
- What happened when one design went wrong? (The Tacoma Narrows Bridge disaster.)
- The challenges faced by the bridge construction crew when making the bridge. How did they arrange for the cables to go from tower to tower?
- Why are the main spans in real suspension bridges arched and why do they include truss construction?
- What alternative designs were considered for the location and why were they rejected?
- In their opinion, are their selected bridges successful structures? Why or why not?

The following general Internet web sites are useful for student research and photographs.

[www.howstuffworks.co](http://www.howstuffworks.co)

[www.brantacan.co.uk](http://www.brantacan.co.uk)

<http://www.pbs.org/wgbh/nova/bridge/meetsusp.html>

Some additional information on suspension bridges:

<http://www.pbs.org/wgbh/amex/goldengate/>

*This site chronicles the construction of the Golden Gate Bridge, San Francisco, USA. It is the accompanying web site to a public television program on the same topic and includes a*

*teacher's guide, a transcript of the TV program, animations, facts about the people and events involved in the bridge and a section incorporating 'bridge math.'*

<http://www.clifton-suspension-bridge.org.uk/>  
*Information on the historic Clifton Suspension Bridge, Bristol, UK.*

<http://www.design-technology.org/suspensionbridges.htm>  
*A good source of general information, with links to other web pages on bridges and aspects of design and technology.*

<http://www.inventionfactory.com/history/RHABridg/sbtd/>  
*Suspension bridge technical data. A very good site full of detailed background information, terminology and drawings to explain suspension bridge design.*

<http://www.bardaglea.org.uk/bridges/bridge-types/bridge-types-suspension.html>  
*A general bridge site. Highly visual with little text. Examples are from the UK.*

# Skill Builder 1

## Student Inquiry Sheet

### *Building a Bridge Can't Be All That Difficult, Can It?*

#### CONSIDER THIS

A bridge is a structure used to cross some form of barrier, making it easier to get from one place to another without having to make long detours.

- What are the key features you think a bridge should have? Make a short list in your workbook or journal.
- What should a bridge not do when you travel across it? Keep these features in mind when you make your own bridges.

In this activity your team is challenged to make 3 simple beam bridges from K'NEX materials and then investigate how they behave when **forces** are applied to them. *Think of a beam as a heavy board supported at either end and used to span a gap.*

#### MATERIALS

- 15 K'NEX Rods of any length from the Real Bridge Building set
- 15 K'NEX Connectors of any color from the Real Bridge Building set
- 50g and 100g weights or slotted masses
- Ruler

**Safety Note:** Please wear safety glasses as you undertake these investigations.

#### CHALLENGE I

- I. What is the longest bridge you can make with the materials provided, that does not break (fail)?

- This bridge does not have to support a load.
- The bridge does not have to be a freestanding structure but can simply span the gap between two desks or two chairs.
- Your team may use a maximum of 15 Rods and 15 Connectors for the bridge.
- You have 20 minutes for thinking, building and recording.
- Measurements required:
  1. The maximum gap your bridge spans.
  2. The maximum gap your bridge spans without sagging or bending.

#### WHAT TO DO?

1. Once your team has selected the Rods and Connectors, spend a few minutes discussing how you are going to tackle the task before starting to build. Some planning before taking action usually helps. You should keep a record of what ideas were rejected, or accepted, and why.
2. If you are unfamiliar with how K'NEX components fit together, ask your teacher if you may have a look at Page 2 of the Real Bridge Building Instructions Booklets.
3. Once you have completed your bridge, take the required measurements.

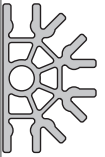

#### SECTION I

# Skill Builder 1

## Student Inquiry Sheet



### SECTION I

#### YOUR OBSERVATIONS

Use drawings and written notes to record your ideas and observations in your notebooks or journals. You may want to include responses to the following questions:

- How does your bridge perform against the expectations you listed at the beginning of this activity?
- Where does the bridge bend the most?
- Why would you not use your long bridge design to cross a barrier?
- How might you strengthen (reinforce) your bridge so it can carry a 100g load at its mid-point?

#### CHALLENGES II AND III

##### II. What is the longest bridge you can build that can span a gap and carry a 100g load at its mid-point?

Your team may use a maximum of 15 Rods and 15 Connectors for the bridge.

##### III. What is the longest bridge you can make that will support a 50g load without sagging or bending?

Your team may use a maximum of 15 Rods and 15 Connectors for the bridge.

- Maximum time allowed: 15 minutes for each challenge.
- Measurement required for Challenge II: The maximum gap your bridge spans.
- Measurement required for Challenge III: The maximum gap your bridge spans without sagging or bending.

#### YOUR OBSERVATIONS

Use drawings and written notes to record your ideas and observations in your

notebooks or journals.

Think about what you have learned about beam bridges:

- Do long beams behave the same way as short beams?
- How and where did your structures fail?
- Why is it important for your beam bridge to remain **rigid** when carrying a load?
- What changes might you might make to strengthen your design so that the beam will remain rigid over a longer distance, even when a load passes over it?
- How do structural engineers solve the problem of keeping the bridge span structure rigid over long distances?

#### REPORTING BACK

Using written text and drawings, produce a short report of no more than 100 words on the **strengths** and **weaknesses** of each of the bridges you made, using the correct technical vocabulary when describing your observations.

- What ideas were rejected or accepted and why?
- How did your bridge perform against your expectations/the design specification?
- What changes did you make to the bridge structure during construction so that it could meet the new design specifications?

#### VOCABULARY

*beam, load, dead load, live load, span, bending, sagging, rigid, fail, failure, strength, design specifications, structure*

### Investigating 2-D Shapes - Rectangles and Squares

#### CONSIDER THIS

Many buildings and structures include rectangular or square shapes in their construction but are they the strongest shapes available for this purpose?

- Think about and make a short list of the advantages and disadvantages of using rectangles in structures.

In this activity your team will investigate how rectangles and squares behave when forces are applied to them. The diagrams below show the most common forces that affect structures:

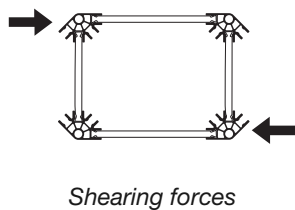
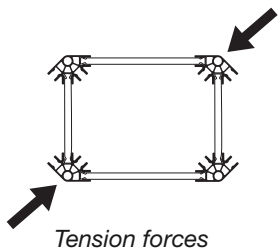
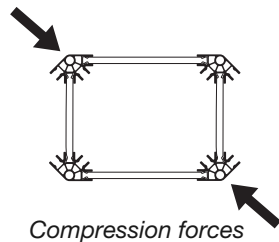

**Compression** forces are squeezing forces.

**Tension** forces are stretching forces.

**Shear** forces work in opposite directions and in different planes to each other.

A less common force is **Torsion**, which acts to twist a material.

#### MATERIALS

- A selection of blue, red, yellow and gray K'NEX Rods
- A selection of K'NEX Connectors
- A rubber band at least 12.5cms (5") long

#### PART 1: What happens when forces are applied to the corners of squares and rectangles?

#### WHAT TO DO?

1. Using blue, red, yellow and gray Rods together with your choice of Connectors, make **3** different sized squares and **1** rectangle. The rectangle should be made using blue and either red or gray Rods.
2. Investigate what happens to the shapes of the squares and rectangles when you apply compression, tension and shear

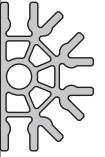

# Skill Builder 2

## Student Inquiry Sheet



### SECTION I

forces to their **corners**, then answer the questions outlined below.

- To help visualize what is taking place construct another square using 4 yellow Rods and 4 blue Connectors. Hook the ends of a rubber band over the prongs of the diagonally opposite Connectors. Use a rubber band that is at least 3/4 the length of the diagonal of the quadrilateral. If you use the arrangement suggested above you will need a rubber band that is approximately 12.5cm (5") long. If you have attached the stretched rubber band (under tension) along the line in which you are applying the force, you should be able to see how the band stretches further, or relaxes, as the structure undergoes compression or tension.

**IMPORTANT SAFETY NOTE:** *If the structure is squeezed or pulled too hard the joints may snap open ejecting one or more connecting Rods from the structure. It is important that you **do not** exert too much force on your K'NEX shapes. Just do enough to see the effect and feel any resistance offered by the shape you are investigating. You should wear safety glasses when carrying out this activity.*

### YOUR OBSERVATIONS

- What happens to the shapes when you apply compression, tension and shear forces to their **corners**?
- Are the shapes deformed (changed)? What new shapes are produced?
- Do all 4 shapes behave in the same way?

- What happens to the joints when the forces are applied?
- What happens to the shapes when the forces are removed?
- Are rectangles and squares stable shapes?

### KEEPING A RECORD

- Record and explain your observations through notes and drawings in your work book or journal.
- Use the correct technical vocabulary to describe and explain your observations.
- Make use of directional arrows to show

**compression:** → ←

**tension:** ← →

and **shear:** →  
←

### PART 2: Will adding more rectangles make a structure more stable?

**DEFINITION:** A **stable** shape is one that is able to resist its shape (**form**) being changed (**deformed**).

Spend a few minutes to think about your response to the question. Record your ideas, together with your reasons, in your workbook or journal. Now test your ideas.

### WHAT TO DO

- Make a chain of equal sized rectangles and triangles and investigate as before. For example:

# Skill Builder 2

## Student Inquiry Sheet

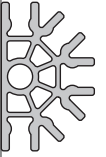

### SECTION I

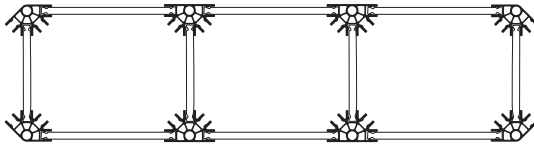

2. Try your own patterns of squares or rectangles and test them. For example:

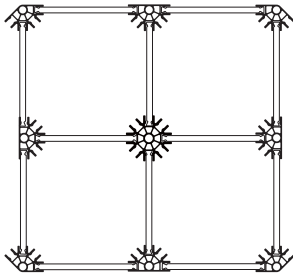

### YOUR OBSERVATIONS

- Did the new shapes behave as you expected them to or did something else happen?
- Do rectangles and squares make **stable** shapes?
- Do rectangles and squares make **strong** structures?

### KEEPING A RECORD

- Record and explain your observations through notes and drawings in your work book or journal.
- Use the correct technical vocabulary to describe and explain your observations.
- Make use of directional arrows to show **compression**:  $\rightarrow \leftarrow$   
**tension**:  $\leftarrow \rightarrow$   
and **shear**:  $\begin{matrix} \rightarrow \\ \leftarrow \end{matrix}$

### PART 3: What happens when the forces are applied to the structural members that make up the sides?

*DEFINITION: A structural member is a part of the structure that may be subjected to external forces such as compression, tension and shear.*

### WHAT TO DO FIRST

1. Make two different sized squares, one from the blue K'NEX Rods and one from the gray Rods.
2. Investigate what happens to the squares when you apply lateral forces to the sides – you will need to gently squeeze the square.
3. Use your knowledge of the effects of loads on beams (**Skill Builder #1**) to predict how the two shapes will respond?
4. Spend a few minutes to think about your response to the question. Record your ideas, together with your reasons, in your workbook or journal. Now test your ideas.

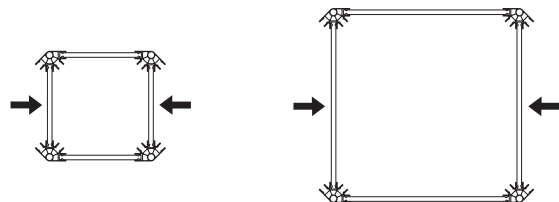

# Skill Builder 2

## Student Inquiry Sheet



### SECTION I

#### YOUR OBSERVATIONS

- Record and explain your observations through notes and drawings in your work book or journal.
- Did the shapes behave as you expected them to or did something else happen?
- Which size of square is the stronger structure?

#### WHAT TO DO NEXT

Investigate what happens when forces are applied along the length (**axially**) of a structural member.

- Use the two different sized squares you used before.
- Stand one of your K'NEX squares on the desktop and push down vertically on one side as shown in A.

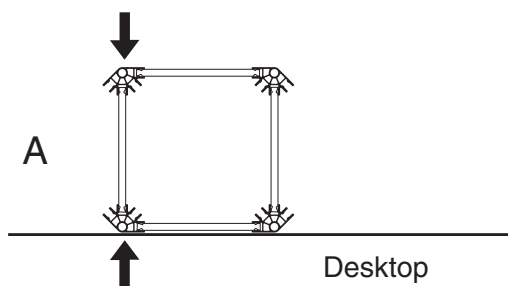

You are now applying an external force axially along a K'NEX structural member. What type of external force is being applied here?

- Use your fingers to pull along the long axis (**axially**) of one side of a square, as shown in B. What type of external force is being applied now?

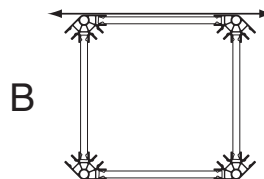

#### YOUR OBSERVATIONS

- Did the shapes behave as you expected them to or did something else happen?
- How do the structural members behave in A?
- How do the structural members behave in B?
- If you were using squares or rectangles to design and make structures, would you use large or small-sided shapes? Explain the reasons for your decision.

#### KEEPING A RECORD

- Record and explain your observations through notes and drawings in your work book or journal.
- Use the correct technical vocabulary to describe and explain your observations.
- Make use of directional arrows to show

**compression** → ←

**tension** ← →

#### VOCABULARY

*frame structures, force, compression, tension, shear, axial, axially, lateral, structure, member, structural member, stable, unstable, deform, stability, joint, strong, weak*



# Skill Builder 3

## Student Inquiry Sheet

### Investigating 2-D Shapes - Triangles

#### CONSIDER THIS

Many structures use triangles in their construction, but what makes the triangle such a useful shape?

In this activity your team will make some triangles from K'NEX and then investigate their structural properties.

What happens, for example, when forces are applied to their corners and sides?

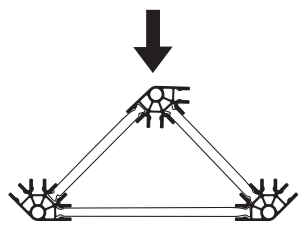

A. Vertical applied force

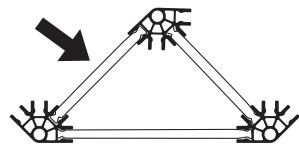

B. Lateral applied force

Fig. 1: External forces acting on triangles

#### MATERIALS

- A selection of K'NEX Rods and Connectors
- Rubber bands

**Important safety note:** If the structure is squeezed or pulled too hard the joints may snap open ejecting one, or more, connecting Rods from the structure. It is important that that you **do not** exert too much force on your K'NEX shapes. Just exert enough to see the effect and feel any resistance offered by the shape you are investigating. When using rubber bands take care they are not overstretched and only used in the way described by your teacher. You should wear safety glasses when carrying out this activity.

#### PART 1: What happens when external forces are applied to the corners and sides of triangles?

#### WHAT TO DO FIRST

1. Using different sized Rods and Connectors from your K'NEX Real Bridge Building set, make three or four different sized triangles.
2. Investigate what happens to the shapes when you apply the external force in the directions shown in Fig.1.

#### OBSERVATIONS

- What happens to the shapes when you apply vertical and lateral forces to your triangles?

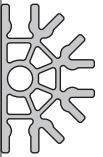

# Skill Builder 3

## Student Inquiry Sheet

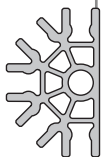

### SECTION I

- Are the shapes deformed (changed)? What new shapes, if any, are produced?
- What happens to the joints when the forces are applied?
- What happens to the shapes when the forces are removed?
- What happens to the structural members?
- Does the length of a side affect how a triangle resists external forces?
- Do all sized triangles behave in the same way?
- Are triangles strong shapes?

### WHAT TO DO NEXT

1. Replace the base of your triangle (A) with a rubber band and apply a vertical force as shown in Fig. 2.
2. Replace a side (B) of your triangle with a rubber band and apply a vertical force as shown in Fig. 2.

*Note: If you use the blue Connectors for the corners of your triangles you can hook the rubber band around the spare prongs of the Connectors. The rubber band should be slightly stretched before you apply the vertical force.*

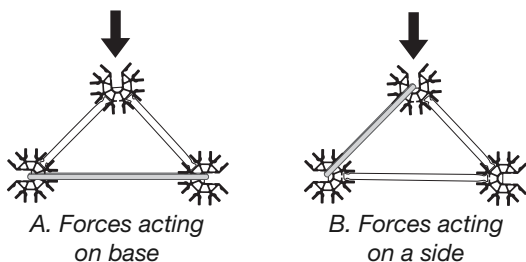

Fig. 2: External forces acting on triangles

### YOUR OBSERVATIONS

- Does the rubber band become stretched or shortened when the vertical force is applied?
- What types of forces are acting on (A) the base and (B) the sides of a triangle when a vertical force is applied?
- In A, note what happens when you press down on the apex of the triangle. Feel the force pushing back against your finger.

### Some background information

*This “backward” force is the resistance of the rubber band to being stretched and is called the **reaction** force. All materials, K’NEX plastic, steel, wood, concrete... behave in a similar way when external forces are applied to them.*

*External forces are called **stresses**. The most important stresses that act on structures and structural members are those that tend to squeeze (**compressive stress**) or stretch (**tensile stress**) them.*

### KEEPING A RECORD

- Record your observations through notes and drawings in your workbook or journal.
- Use the correct technical vocabulary to describe and explain your observations.
- Make use of directional arrows to show
  - compression:** → ←
  - tension:** ← →
  - and **shear:** → ←

# Skill Builder 3

## Student Inquiry Sheet

### PART 2: Will adding more triangles make a frame structure stronger?

Spend a few minutes to think about your response to the question. Record your response to the question. Record your responses, together with your reasons, in your workbook or journal.

### WHAT TO DO

1. Make a chain of equal sized triangles (See Fig. 3) and investigate as before.

*NOTE: A framework of triangles, as used in Fig. 3, is called a truss construction.*

The top edge is called the upper **chord**

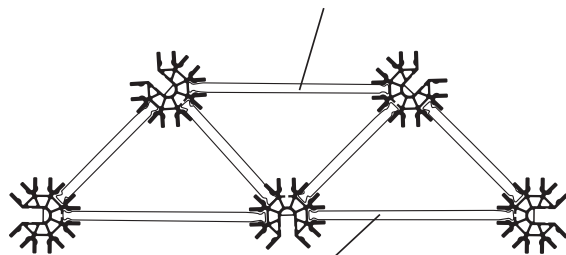

The lower edge is called the lower **chord**

Fig. 3: Chain of triangles

2. Now test your ideas:
  - Place one end of your truss construction on the edge of the desk while your partner holds the other end. Either press down gently, but firmly, on the upper chord or pull down on the lower chord.
  - Record your observations through notes and drawings in your workbook or journal.
3. Next, try this. Just as you did in Part 1, replace K'NEX structural members with

rubber bands, as shown in Fig. 4.

4. Press down at the point indicated by the arrow and observe what happens to the rubber bands.

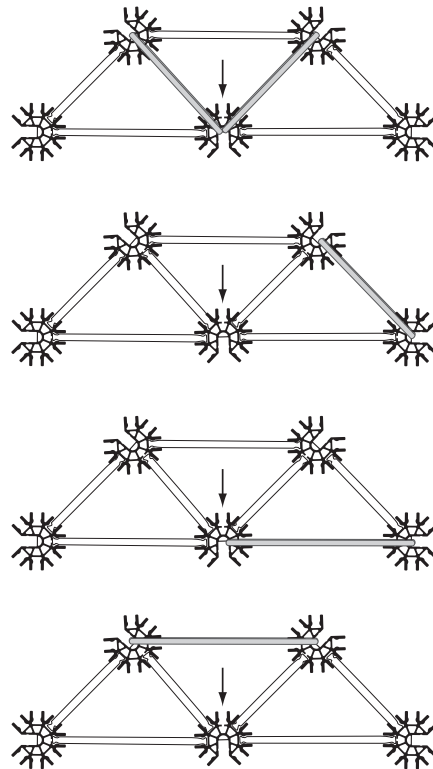
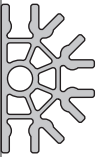

Fig. 4: Replacing the K'NEX structural members

*Construction hint: Use blue Connectors to join the Rods, then you can hook the ends of the rubber band around the spare prongs of the Connector.*

### YOUR OBSERVATIONS

- What forces are acting on the members that you are investigating?
- Record your observations and explanations through notes and drawings in your workbook or journal.



# Skill Builder 3

## Student Inquiry Sheet

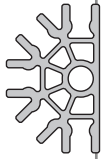

### SECTION I

- Use the correct technical vocabulary to describe and explain your observations.
- Make use of directional arrows to show **compression**:  $\longrightarrow \longleftarrow$   
**tension**:  $\longleftarrow \longrightarrow$   
and **shear**:  $\longrightarrow \longleftarrow$

### DESIGN CHALLENGE

What is the longest linear truss construction you can make that will not bend or sag under its own weight or under a small load?

1. Before you start to build, spend a few minutes to think about your response to the challenge. Consider the results you obtained from the Skill Builder #1 bridge building activity and your investigations in this activity.
2. Record your estimate, together with your reasons, in your workbook or journal.
3. Now build your truss construction and test as before.
4. Did your truss construction behave as expected? If not, why not?
5. How did the performance of this type of truss bridge structure compare with the simple beam construction you used in Skill Builder 1? (Turn your truss onto its side to make a simple beam bridge construction and compare.)
6. Record your observations and explanations through notes and drawings in your workbook or journal.

### PART 3: Investigating triangle patterns

#### WHAT TO DO

Design and test the performance of your own patterns of triangles. For example:

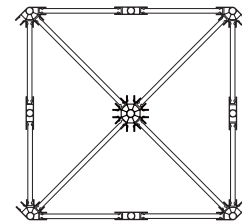
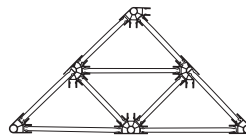

#### YOUR OBSERVATIONS

- Did your triangle shapes behave as you expected them to or did something else happen?
- Make a list of the types of structures in which you have seen these shapes used; what was their function?
- Why do you think triangles were used in their design?
- Record and explain your observations through notes and drawings in your workbook or journal.

#### VOCABULARY

*triangle, vertical applied force, lateral applied force, joint, deform, structural member, reaction, stress, compressive stress, tensile stress, compression, tension, shear, upper chord, lower chord, truss*

# Skill Builder 4 Student Inquiry Sheet

## Strengthening 2-D Shapes

### CONSIDER THIS

Many large structures, such as pylons and cranes, use a combination of rectangular and triangular shapes in their designs. From previous Skill Builder activities you learned that rectangular shapes are not as structurally strong as triangular structures.

In this activity your team will investigate how triangles can be used to strengthen rectangular frame structures.

### MATERIALS

- A selection of K'NEX Rods and Connectors
- Rubber bands
- String (approximately 30cm/12in)
- Paper or light card
- Scissors
- Single-hole punch

**Important safety note:** If the structure is squeezed or pulled too hard the joints may snap open ejecting one, or more, connecting Rods from the structure. It is important that you **do not** exert too much force on your K'NEX shapes. Just do enough to see the effect and feel any resistance offered by the shape you are investigating. When using rubber bands take care they are not overstretched and use them only in the way described by your teacher. You should wear safety glasses when carrying out this activity.

### PART 1: How can square and rectangular frame structures be strengthened to resist compression, tension and shear forces to their corners?

#### WHAT TO DO FIRST

1. Look at Fig. 1 to remind yourselves of the main types of external forces that can act on rectangular frame structures.

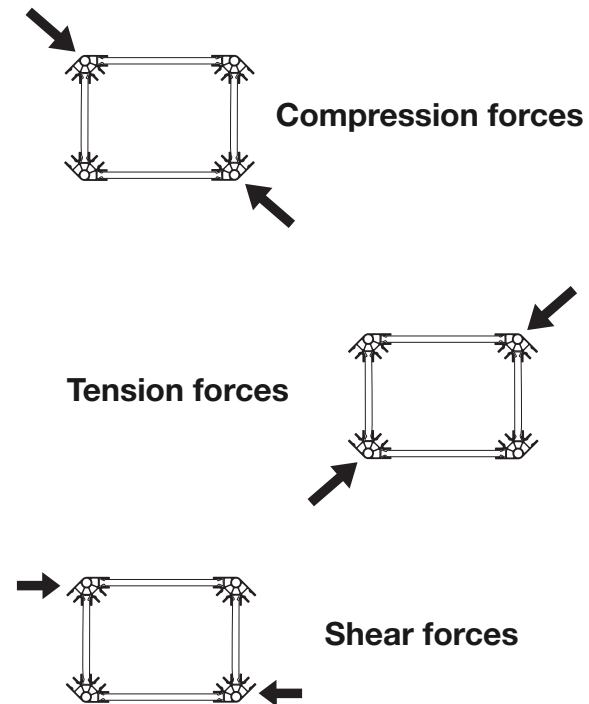
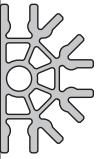

Fig. 1: External forces that act on rectangular frame structures



### SECTION I

# Skill Builder 4

## Student Inquiry Sheet

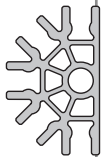

### SECTION I

2. Make 3 different sized squares and 1 rectangle. You should use blue, red and gray Rods from your K'NEX Real Bridge Building set, together with Connectors. The rectangle should be made using blue and red or red and gray rods.
3. Before you start your investigation, spend a few minutes to think how the frame structures you have made can be strengthened. Record your ideas, together with your reasons, in your workbook or journal.
4. Now apply and then test your ideas. Additional K'NEX components will be needed to strengthen your shapes.

### YOUR OBSERVATIONS

- What happens to your strengthened square and rectangular frame structures when you apply compression, tension and shear forces to their corners?
- Were you able to reinforce all of the shapes using K'NEX? Which shape presented problems?
- Do all the structures behave in the same way?
- What happens to the joints when the forces are applied?
- What happens to the structures when the forces are removed?
- What new shapes are now present in your structures?

- Which parts of your strengthened frame structure are under compression and tension when tested?
- Explain how each shape has been made into a strong frame structure? (Remember you can also see the forces at work on a structural member if you substitute a rubber band for the K'NEX Rod.)

### Keeping a Record

- Record and explain your observations through notes and drawings in your work book or journal.
- Use the correct technical vocabulary to describe and explain your observations.
- Make use of directional arrows to show  
**compression:**  $\longrightarrow \longleftarrow$   
and **tension:**  $\longleftarrow \longrightarrow$

### PART 2: Does the use of triangles always produce strong, rigid structures?

#### WHAT TO DO

1. Before you start your investigation, spend a few minutes to consider this question. Record your answer, with an explanation, in your workbook or journal.
2. In Part 1 you discovered that using triangles in structures (**triangulation**) helps make them **rigid** and **strong**. Here are two frame structures to investigate. Structure 1 contains three triangles while Structure 2 has two triangles – but is one more rigid and stronger than the other?

# Skill Builder 4

## Student Inquiry Sheet

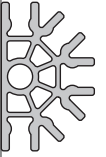

### SECTION I

How will they behave when vertical and lateral external forces are applied to them?

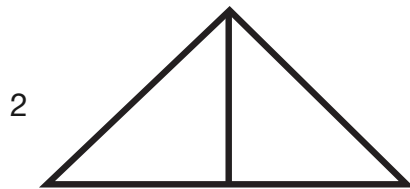
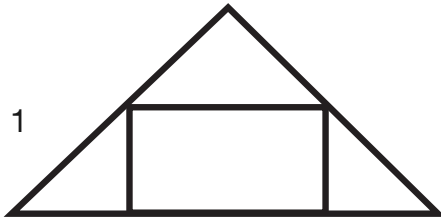

*Information: Structure 1 is an example of a Queen Post Truss and Structure 2, a King Post Truss.*

3. Record these shapes in your workbooks or journals. Explain which one you think is the stronger and more rigid structure and why.

4. Now build and test the two structures to check if you are correct. You will need the following K'NEX pieces from your Real Bridge Building set:

- 7 yellow Rods
- 10 blue Rods
- 7 yellow Connectors
- 4 light gray Connectors
- 2 gray Connectors

### Figure 1. Queen Post Truss

- The base is made from 2 blue Rods and 1 yellow Rod joined by 2 yellow Connectors. At each end add a light gray Connector.
- Each side can be made from 1 yellow and 1 blue Rod joined by a yellow Connector. Complete the triangle by adding a gray Connector at the apex.
- The central rectangle can be made using blue and yellow Rods.

### Figure 2. King Post Truss

- Build the base using 2 yellow Rods joined by 1 yellow Connector and at each end add a light gray Connector.
- Construct each side from 2 blue Rods joined by 1 yellow Connector. Complete the triangle by adding a gray Connector at the apex.
- The vertical column is a yellow Rod.

5. How would you modify both structures to make them stronger?

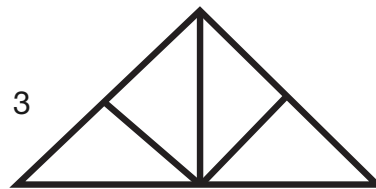

6. Here is a third frame structure to investigate. This is the strongest and most rigid of the three examples you have been given. True or false?

# Skill Builder 4

## Student Inquiry Sheet

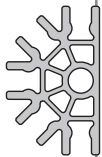

### SECTION I

7. Now build and test the structure to check if you are right. You will need some additional K'NEX pieces.

### YOUR OBSERVATIONS

- Does the use of triangles always produce strong rigid structures?
- Compare your findings with your original answer.

### KEEPING A RECORD

- Record and explain your observations through notes and drawings in your work book or journal.
- Use the correct technical vocabulary to describe and explain your observations.
- Make use of directional arrows to show **compression**:  $\longrightarrow \longleftarrow$  and **tension**:  $\longleftarrow \longrightarrow$

### PART 3: Materials such as steel cables, rope and string are only strong when under tension. How can materials such as these be used to strengthen frame and other structures?

In this activity you will investigate how a material (string), that is strong only under tension, can be used to strengthen weak frame structures.

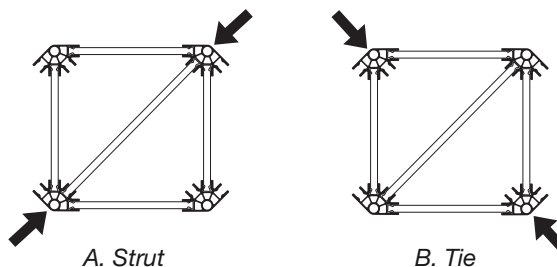

A weak rectangular structure can be strengthened using a diagonal brace. A diagonal brace is called a *strut* when used to resist compression and a *tie* when resisting tension.

### WHAT TO DO

1. Build a K'NEX square or rectangle as before and test its ability to resist external forces as shown in the drawings above.
2. Now replace the K'NEX diagonal member using string and test again. Note: There is no need to tie knots at each corner. Simply wrap the string around the Connector prongs a few times.
3. Before you start to test the structure, record the shapes labeled C, D, and E (shown below,) in your workbooks or journals and predict how you think the shape of the frame structure may or may not be deformed (changed).
4. Now test your predictions.

### YOUR OBSERVATIONS

- Observe and record what happens to the square and string as you apply external forces as shown in C, D and E below.



# Skill Builder 4

## Student Inquiry Sheet

- What forces are acting on the structure and string?

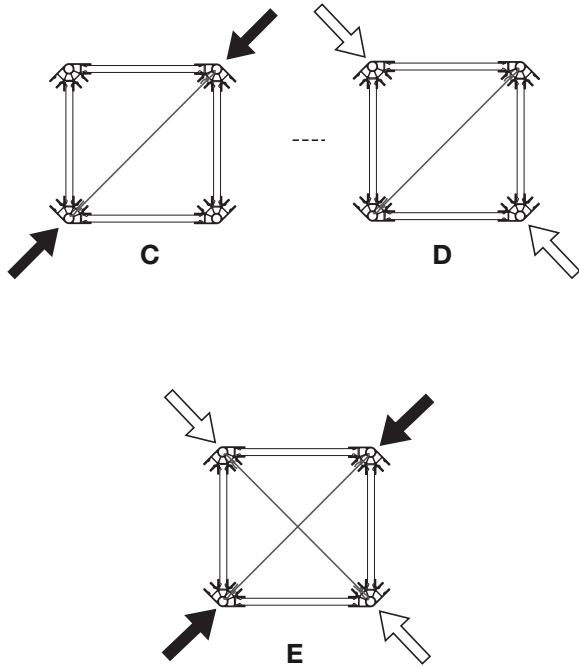

### WHAT TO DO NEXT

1. Place the square structure on a flat surface and insert a small gray Rod vertically into the hole in each of the corner Connectors.
2. Punch holes at each end of a strip of paper or thin card and fit the holes in the paper over two of the white Rods, as shown below.
3. Now repeat the activity in which you apply external force to the structure.

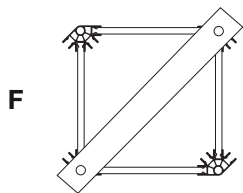

### YOUR OBSERVATIONS

- Observe what happens to the paper strip when forces are applied to the structure.
- A similar exercise could be carried out with a sheet of paper cut to the same size as the K'NEX flexible square. In this case the paper is acting as a tension member.

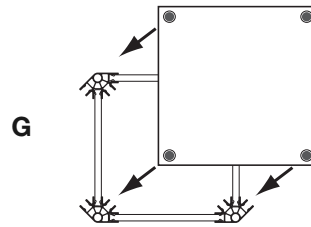

Once the paper sheet is in place it acts in the same way as the diagonal members in A and B. This method of strengthening a frame structure is called a **diaphragm** and is often used to make rigid walls or floor panels in frame buildings.

### KEEPING A RECORD

- Record and explain your observations through notes and drawings in your work book or journal.
- Use the correct technical vocabulary.
- Make use of directional arrows to show

**compression:** → ←  
and **tension:** ← →

### VOCABULARY

*triangulation, diagonal brace, strut, tie, compression, tension, members, stable, unstable, stabilize, strong, rigid, stress, queen post truss, king post truss, diagonal, diaphragm*

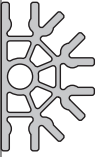

## SECTION I

# Skill Builder 5

## Student Inquiry Sheet

### Making 3-D Frame Structures - Cubes



#### SECTION I

#### 5A: INVESTIGATING A CUBE STRUCTURE

##### CONSIDER THIS

In earlier activities you investigated the effect of external forces on 2-D shapes and structures and explored how triangulation can be used to strengthen frame structures. In this activity you will use this knowledge to make and strengthen 3-D frame structures.

##### Materials

- A selection of K'NEX Rods and Connectors
- Building Instructions Booklet: Page 2
- Weights (books or 500-1000g masses)

**Safety Note:** Please wear safety glasses as you undertake these investigations.

#### PART 1: Investigating the effects of external forces on a cube

##### WHAT TO DO FIRST

- Fig. 1 is an isometric drawing of the cube you will make using your K'NEX Real Bridge Building set materials.

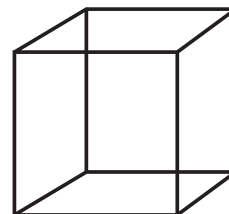

Fig. 1: Isometric drawing of a cube

To construct your cube you can use EITHER:

- Blue Rods and a combination of blue and gray Connectors (see Page 2 of the Building Instructions for how to join these Connectors). This will build a small cube.

OR:

- Red Rods and all gray Connectors. This will build a larger cube.

1. Estimate how many Rods and Connectors you will need to make your cube.
2. Build either the blue cube or the red cube.
3. Now investigate how your cube behaves when supporting a large load. The **load** (books or masses) will be placed on the top of your cube. This means that the load forces will act **vertically** on your structure.
  - What other investigations did you carry out that involved vertically applied forces acting on rectangular frame structures?

# Skill Builder 5

## Student Inquiry Sheet

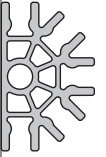

### SECTION I

### YOUR OBSERVATIONS

- What is the largest load your cube can support before there are signs that the structure is failing? (Do not load it so much that it actually fails.)
- How and where did the failure occur?
- What type of force acts on the vertical structural members of your cube?
- Rectangles are weak structures but what do you notice about the size of load that a cube can support?
- Compare your results with a group that built a different sized structure. Is one stronger than the other, based on your loading of the cubes?

### KEEPING A RECORD

- Record your observations and explanations using notes and drawings with directional arrows to indicate the types of forces acting on the structural members. You should use the correct technical vocabulary in all written and descriptive text.

### WHAT TO DO NEXT

**How does your cube behave when subjected to different types of forces?**

- There are four main types of force that can affect structures: shear; compression; tension and torsion. See Fig. 2: Forces acting on cube faces.

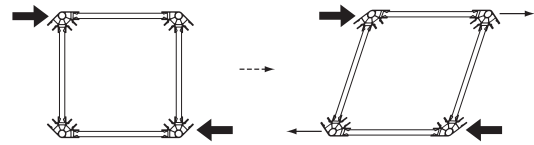

Shearing forces

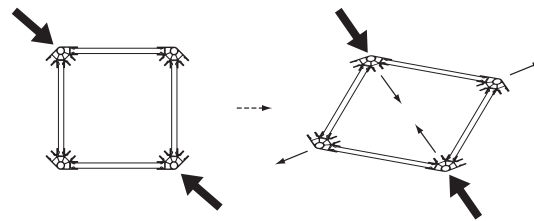

Compression forces

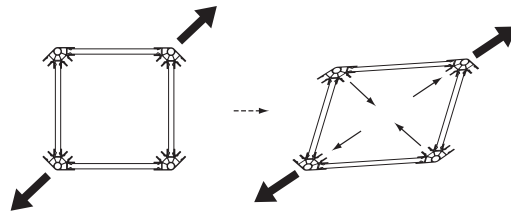

Tension forces

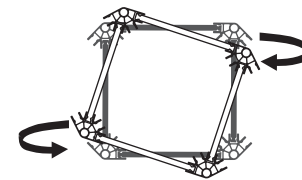

Torsion forces

Fig. 2: Forces acting on cube faces

4. Before starting your investigation, spend a few minutes to think about the question. Record your ideas, together with your reasons, in your workbook or journal.
5. Now test your ideas.

# Skill Builder 5

## Student Inquiry Sheet

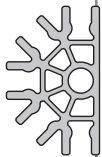

### SECTION I

**Important safety note:** If the structure is twisted too much then the joints may snap open ejecting one or more connecting Rods from the structure. While this effect demonstrates a dramatic failure of the structure, you should not exert too much force on the structure because of the potential hazard from the ejected Rods. Make sure you are wearing safety glasses.

### YOUR OBSERVATIONS

- Did your cube behave as you predicted? If not, why not?
- Why do you think your cube behaved in the way it did when subjected to the different forces?
- How might you strengthen your cube structure?

### PART 2: Strengthening 3-D cube structures

In earlier investigations you discovered:

- Weak 2-D rectangular structures could be strengthened using triangulation.
- Triangulation can involve the use of diagonal braces that can act to resist compression (struts) and/or tension (ties).
- A K'NEX cube is an example of a frame structure.

### WHAT TO DO

1. In this investigation you will use triangulation (adding struts and ties) to reinforce and strengthen your K'NEX cube.

- **K'NEX Rods** can be used as struts
- **String** can be used as tension members

*Note: Do not cut the string that comes with your K'NEX Real Bridge Building set, as it is needed for other activities. If other lengths of string are not available you can simply wrap the K'NEX string around the open Connector joints.*

2. Modify your cube using EITHER the gray Rods (for the red cube) OR the yellow Rods (for the blue cube) and string.
3. Test your cube by applying the same external forces as you used on the un-reinforced structure.

### YOUR OBSERVATIONS

- Must triangulation be applied to all faces of your cube to strengthen it?
- How does triangulation affect the rigidity of your K'NEX cube?

### TALK ABOUT

- How do the designs of electricity pylons, crane jibs and tall radio masts take into account the forces that act on them?

### KEEPING A RECORD

- Record your observations and explanations using notes and drawings with directional arrows to indicate the types of forces acting on the structural members.

# Skill Builder 5

## Student Inquiry Sheet

### 5B: EXTENDING THE ACTIVITY - MAKING LONG BEAM BRIDGES

#### CONSIDER THIS

In this activity you will work in a team of 4-6 to construct 2 beam bridges, each with a span of 70-80cm. You will build your beams from a chain of cubes or rectangles, but one beam will be thicker than the other.

- Beam A will be made using the white Rod as the depth measure.
- Beam B will be made using the yellow Rod as the depth measure.
- Do not use any triangulation in the first part of the investigation, just build a connected chain of cubes or rectangles.

Beam A



Beam B

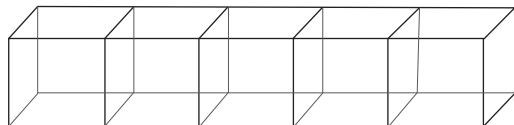

**Safety Note:** Please use safety glasses when undertaking these investigations.

#### WHAT TO DO FIRST

1. Plan how you will construct your beam bridge. You might want to consider the following:
  - a. How can you use your resources most effectively?
  - b. Do you need to draw a flow chart of the tasks that have to be completed?
  - c. How many K'NEX components are needed? (You can use your previous experience of constructing cubes to help you estimate.)
  - d. Can any parts be pre-assembled?
  - e. Does everyone have a specific job to do?
2. Collect your parts and construct the two beams. Remember: do not use triangulation yet.
3. When completed, balance the beams on sets of piers (books can be used, but make sure both sets are the same height) and load each beam at its mid-point. Add weight until the beams begin to sag. Make a note of this weight.
4. OPTION: You could use two top loading/top pan balances as the piers. Observe what happens as you move the load along the beam.

#### YOUR OBSERVATIONS

- Did Beam A and Beam B behave differently when loaded? If so, in what way?
- Where does the load have to be located on the beam for the piers to experience the least amount of force?

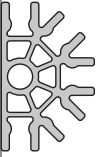

# Skill Builder 5

## Student Inquiry Sheet

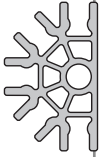

### SECTION I

#### WHAT TO DO NEXT

5. Triangulate your beams: Add struts and ties and then repeat the same investigation.
6. Compare the results of the un-reinforced beams with the reinforced beams.
7. Compare the results of the reinforced Beam A with reinforced Beam B.
8. Does triangulation improve the load bearing performance of a beam?

#### KEEPING A RECORD

- Record the results of your investigations. You may want present these in the form of a simple table or graph.
- Include diagrams wherever you think they may be helpful.

#### 5C: APPLYING THE CONCEPT - INVESTIGATING HOW ENGINEERS HAVE USED TRIANGULATION TO MAKE REAL BRIDGES

##### CONSIDER THIS

In Skill Builder #5A you investigated how 3-D frame cube structures can be reinforced using triangulation.

When designing structures it is important to know which parts of your structure will be under compression and tension. You may recall that long beams can bend when they are subjected to compression and tension at the same time. Structural members,

however, are strongest when compression or tension forces act axially (along their length).

For this activity you will be working as part of a team of 4-6 to build and then investigate the design of the Astoria Bridge in Oregon.

At the end of your investigation you should produce your own report on the bridge design. This will include the results of your group investigations.

You could also use the Internet to search for additional, relevant information and if available, a digital camera to record features of your model design and the results of any tests carried out.

#### MATERIALS

- K'NEX Real Bridge Building set
- Building Instructions: Book 2 for the Astoria Bridge.
- Slotted masses (10g-1000g)
- Ruler

#### WHAT TO DO

1. Before your group starts construction, take a few minutes to look through the building instructions for your bridge. Then ask yourselves the following:
  - Does every team member understand the building instructions?
  - How do you, as a team, plan to construct it?
  - What roles are needed to complete the task?

# Skill Builder 5

## Student Inquiry Sheet

- How will you organize the supply of materials?
- Does everybody need to be involved in construction? Can those not involved in construction carry out an Internet search for information that can be used by the rest of the team to compile their reports?
- Make the best use of the team's available time and resources.

2. Now construct your K'NEX Real Bridge model in the time allocated by your teacher.

3. Investigate the model bridge's load bearing ability, the forces acting on it, how they affect the bridge and where you might expect failure to occur.

### YOUR OBSERVATIONS

Your investigations should provide responses to the following:

- What is the maximum load the bridge can support at the mid-point of its span? Note where and how any failure in the structure occurs.
- How does your K'NEX bridge model behave when loaded in different positions?
- What forces are acting on your model when it is under load and how do they affect it? Do parts of the model move? How are these potentially disastrous problems solved in the real bridge structure?
- Would you use the K'NEX model design as the basis for a full-scale construction?
- How does the K'NEX bridge design behave when subjected to **torsion**,

as might occur in the real bridge in high winds? How does the real bridge design take into account the effects of torsion due to high winds?

- What are the structural engineering concepts used in the bridge design and how were they applied?
- Why is the road decking of the Astoria Bridge slightly arched?
- Compare the design of your K'NEX bridge model with the real bridge. Use photographs obtained from the K'NEX Building Instructions booklet or from approved Internet web sites.

### EXTENDING THE INVESTIGATION

Carry out an Internet investigation on the Astoria Bridge using some of the Internet links below. These sites provide you with some additional facts, statistics and photographs with which to analyze the design and construction of your bridge. Some areas you may want to research:

- The design challenges caused by the physical conditions of the site and how they were solved.
- The types of forces acting on the bridge and how the design takes them into account.
- Why this particular type of bridge design was chosen for this location.
- The challenges facing the bridge construction team and how they were overcome.
- The alternative designs that were considered and why they were rejected.
- In your opinion, is the bridge a successful structure? What are your reasons for your opinion?

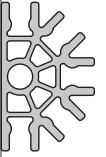

## SECTION I

# Skill Builder 5

## Student Inquiry Sheet

This is a useful web site for the Astoria Bridge.

<http://www.oldoregon.com/visitor-info/entry/astoria-megler-bridge/>

You can obtain additional resources by entering Astoria Bridge – Oregon in a search engine.

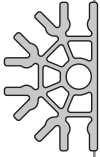

### SECTION I



# Skill Builder 6

## Student Inquiry Sheet

### Spanning Gaps - Beams or Arches?

#### CONSIDER THIS

The history of bridge building documents the ways in which engineers have tackled the problem of crossing wider and wider barriers. To cross wide gaps, strong and rigid structures are needed.

In earlier activities you investigated the use of **triangulation** to strengthen 3-D frame structures. Here you will investigate an alternative way of strengthening a **simple beam bridge** so that it can extend across wider gaps. You will then compare its characteristics with those of an **arch** – a design that has been used in structures for thousands of years.

You will compare the **load bearing ability** of each type of bridge by measuring the amount of sag or bend (**deflection** is the term normally used) caused by placing a 500g load at the mid-point of the bridge **span**.

You will make your **simple beam bridge** by modifying (slightly) the building instructions for the K'NEX Real Bridge model of the Chesapeake Bay Bridge-Tunnel (Book 1). Your investigations into the arch will use a length of black bridge decking from the same set.

On completion of your investigations, you will write a short report of no more than 200 words on the two bridge designs, so keep notes and drawings of your findings and observations as you go along.

**Safety Note:** Please wear safety glasses as you undertake these investigations.

#### MATERIALS

- K'NEX Real Bridge Building set
- Building Instructions for the Chesapeake Bay Bridge (Book 1)
- Rulers and pencils
- Slotted or other masses (10g- 1000g)
- Sheets of white paper

#### PART 1: BEAMS

### To investigate the load bearing ability of supported and unsupported beam bridges

#### WHAT TO DO

- Work in a team of 4-6. Familiarize yourselves with the building instructions before you start to build.
- **Half the team** will build 2 sections of the Chesapeake Bay Bridge. Suggestion: Build **3 pairs of supporting piers** (Step 1 on Page 5) and **8 lengths of deck** (Step 2, 4 and 6). Join the sections together (Step 3, 5 and 7) to form your bridge. Add the black decking.
- The **other half of the team** will build the equivalent length of bridge but with piers only at each end. There will be no central supports in this bridge. Add black decking.

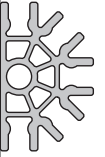

#### SECTION I

# Skill Builder 6

## Student Inquiry Sheet

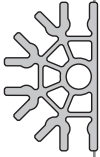

### SECTION I

- Each bridge should be placed so that its piers are standing on a sheet of paper. Draw around the base of the piers so you have a record of their original position.
- Now add loads to your bridges and observe what happens. Begin with 10g and continue up to 1000g, if possible.
- Think about:
  - How you will measure the amount of bending (**deflection**) in your beam.
  - How you will record your results.
  - How you will present your results to make them easy to interpret.

### YOUR OBSERVATIONS

For each bridge:

- What happens to the bridge decking and to the position of the piers as you load your bridge?
  - Identify any movement of the piers by marking their new position on the paper and note the load that the bridge is carrying.
  - Are the piers moving outwards (splaying) or inwards?
  - What load is the bridge carrying when you first see evidence that the beam is bending?
  - What is the maximum load the bridge can carry? How great is the deflection of the beam when carrying this weight?
- Safety Note: DO NOT LOAD YOUR BRIDGE TO FAILURE.**
- Compare your findings for each bridge. Which bridge was able to carry a load more successfully? How do you explain this observation?

### KEEPING A RECORD

- Record your observations using notes, labeled drawings and directional arrows.
- You could display your measurements in the form of a data table in which you plot load against the measured amount of splaying and/or weight against the measured amount of beam deflection (bending).

### PART 2: ARCHES

#### To investigate the load bearing ability of an arch bridge

### WHAT TO DO FIRST

- Work in a team of 2-3. You will need a length of black bridge decking from the K'NEX Real Bridges set.
- Gently bend the piece of decking into an arch shape.
- Lower your hands to the desktop, still holding the arch in shape. What do you feel?
- Relax your hold on the arch slightly. What happens?
- How do you maintain the arch shape?
- Take turns doing this.

You should feel both ends of the arch pushing against your hands. To keep the arch shape, you have to push **in** against the arms of the arch as they push **out** against your hands.

# Skill Builder 6

## Student Inquiry Sheet

### WHAT TO DO NEXT

- One team member should hold the arch in place while another carefully loads the mid-point of the arch with a 500g mass. Observe what happens to the arch. Repeat with larger masses.

### YOUR OBSERVATIONS

- When loaded with a 500g mass does the arch show evidence of bending or sagging?
- What happens to the arms of the arch as the load is increased?
- What must you do to enable the arch to keep its shape?
- What will happen to the arch if you remove your hands?
- Can the supported arch carry a 1000g mass?
- How wide a gap does the arch span when carrying this weight?
- What type of forces are involved in supporting arch bridges?
- What makes the arch a strong structure?

### COMPARING THE BEAM AND ARCH

- Now undertake a similar investigation using the length of decking as a beam. Carefully straighten it and then rest the ends either on books or on the piers you built for the first investigation.
- Load the beam at its mid-point with a 500g mass and observe what occurs.
- How wide a gap can the beam span when carrying this load?
- What is the maximum load that this beam can support? How wide is the gap it spans?

- How does this compare with the load it could carry when it was converted into an arch?
- What types of forces are involved in supporting a beam bridge?

### KEEPING A RECORD

- Record and explain your results and observations through notes and drawings in your workbook or journal.
- Use the correct technical vocabulary to describe and explain your observations.
- If available, use a digital camera to record your investigation activities.

### TO COMPLETE YOUR REPORT

1. Compare the load bearing abilities of beam and arch bridges.  
You may want to include the following:
  - The maximum gap each bridge can span while carrying similar loads.
  - The forces that act on each bridge when under load.
2. Where, and in what types of locations, are beam and arch bridges used?
  - Why do their bridge designs suit particular locations?
  - Look at the facts and figures relating to the Chesapeake Bay Bridge-Tunnel and the Sydney Harbour Bridge in the K'NEX Real Bridge Building Instructions booklets.

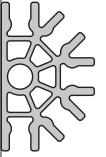

## SECTION I

# Skill Builder 7

## Student Inquiry Sheet

### Investigating Cantilevers

#### CONSIDER THIS

The investigations you have carried out so far involved simple beams. Beams are structural members that are subject to bending forces. You have seen how a simple beam supported at both ends tends to bend in the middle.

A **cantilever** is a beam that is supported at one end only. A diving board is an example of a cantilever. Think about how a spring board for diving works: with no one on it, the diving board is horizontal but as a diver moves to the free end it bends.

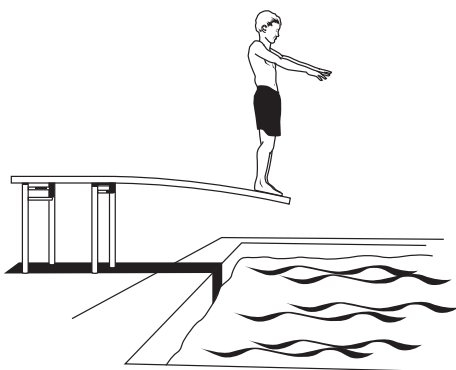
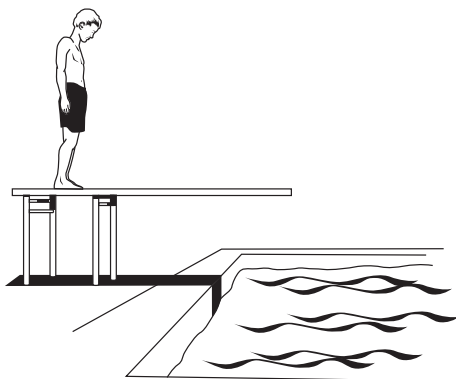

Wouldn't this suggest that a cantilever is actually unsuited for use in bridge construction? Why might it be used instead of a simple beam? How can it be made stable so that it doesn't bend down when under a load? Does it need to be balanced or supported in some way? In the following investigations you will explore how the cantilever can be used to build bridges, as well as a wide range of other structures.

**Safety Note:** Please wear safety glasses as you undertake these investigations.

#### MATERIALS

- K'NEX Real Bridge Building set
- Building Instructions Booklet: Book 1
- Slotted 100g masses
- Spring scales
- String
- Rulers

#### PART 1: Investigating the effects of forces on a cantilever beam

##### WHAT TO DO FIRST

1. You can feel the forces acting on a cantilever by simply holding the very end of a length of black decking from the K'NEX Real Bridge set, or a ruler, in your fingertips. Holding it firmly with some pressure applied will make sure that the

# Skill Builder 7

## Student Inquiry Sheet

'beam' remains level, but as soon as you release the pressure of your fingers it will start to bend downwards.

2. Ask a team member to carefully add a small weight to the end of the 'beam'.
  - What do you notice about the force you need to apply to keep the 'beam' level?
  - What happens if you hold the beam closer to the middle of its length and your partner adds the same weight?
  - Take turns experimenting.
3. Now place the 'beam' on an upright book so that most of it is unsupported – as it was when you held the end of it in your fingers. Unless you hold it in place, it will probably fall.
  - Add weight to the part of the decking that rests on the book.
  - Can you balance the beam so that it extends out horizontally without bending downwards?
  - Try adding a weight to the free end. What do you need to do in order to keep the 'beam' horizontal?

This is the principle of the cantilever – it can extend unsupported for a considerable distance so long as the opposite end acts as a counterbalance.

### WHAT TO DO NEXT

1. Refer to the hinged cantilever that can be found in the bridge raising mechanism of the K'NEX Tower Bridge model - Book 1, Page 41: Steps 25 – 28. You will need to **modify Step 24 by replacing the white vertical supports with longer yellow Rods.**

2. Before starting construction, spend a few minutes familiarizing yourselves with the building instructions and the modification you have been asked to make.
3. Build your model and take time to investigate how it works.

### THEN DO THIS

Investigate the forces that act on a cantilever beam.

4. You can test the load bearing ability of your K'NEX cantilever beam in the following way:
  - a. Place a 100g load at the free end of the beam.
  - b. Observe the deflection or bend in the beam caused by load.
  - c. Measure the force needed to raise the beam back to a horizontal position by pulling back on the blue lever mechanism.
5. Spend a few minutes to plan how you will carry out the investigation. Refer to Fig. 1 below. Measurements and observations to be made include:
  - **L**ength of cantilever beam (**L**).
  - The **D**eflection at the free end of the beam (**D**).
  - The **F**orce required to return the main part of the beam to a horizontal position (**F**).
  - The effect of the cantilever beam on the vertical support (**S**).

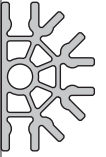

## SECTION I

# Skill Builder 7

## Student Inquiry Sheet



### SECTION I

Consider

- How you will measure the amount of deflection of the cantilever beam?
- How you will record and present your results to make them easy to interpret?

6. The starting point for loading the cantilever beam should be as close to the hinge as possible.
7. What happens when you load a longer cantilever beam? Test it and see. You can increase the length of the beam by inserting additional blue Rods and yellow Connectors into the bridge beam at the hinged end.

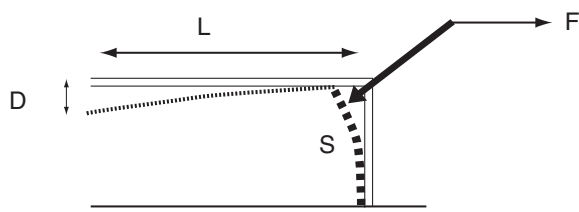

Fig. 1

### YOUR OBSERVATIONS

- Explain what happens to the cantilever beam as its length increases.
- Explain the effect of lengthening the cantilever beam on its vertical support? How might this affect the cantilever bridge design?
- What is the longest length of your cantilever beam (not the vertical support) that can support a 100g load without bending?
- Where would you position the load so that the stresses on the cantilever beam are **maximized**?

- What parts of a cantilever beam are under compression and tension? Compare your findings with a beam that is simply supported at both ends.

### KEEPING A RECORD

- Complete your investigation by recording your observations and explanations using the correct technical vocabulary.
- You should also include drawings of models used in the investigation and include descriptions of the forces acting on the main parts of the structure.

### PART 2: Investigating how a long cantilever beam can be supported to make a stronger structure

#### CONSIDER THIS

In earlier Skill Builder activities you used triangulation to produce strong structures from weak ones.

- **How might triangulation be used to support your hinged cantilever beam?**

Spend a few minutes discussing this with other members of your group and record your ideas and suggestions in your workbooks or journals.

#### WHAT TO DO FIRST

Pushing up from below and/or pulling up from above can support a cantilever beam.

1. Try making the models outlined below

# Skill Builder 7

## Student Inquiry Sheet

and investigate their load bearing abilities.

- You will need to use an extended cantilever beam for these activities. Add blue Rods and yellow Connectors (described on previous page) to extend the length of the beam.

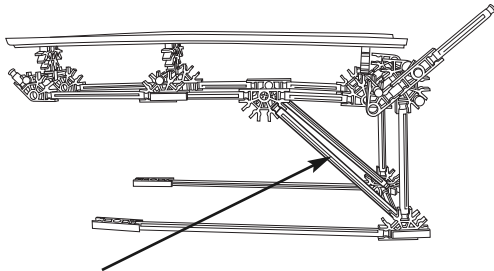

Add red Rod here

A. Pushing up from below

Use a red Rod as a strut. The upper part of the Rod can be connected to a yellow Connector, while the lower end can be wedged in the angle at the base. The **strut** now forms the third side of a triangle.

- What types of forces are acting on the strut?
- Does adding a strut help increase the load bearing ability of the cantilever?

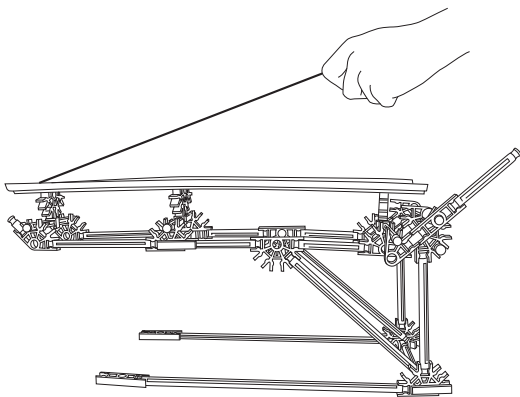

B. Pulling up from above

A string attached to the free end of the cantilever can be used to pull the cantilever up. The string acts as a **tension member** or **tie**.

- How is a triangle formed in this model?
- What types of forces are acting on the tie?

### YOUR OBSERVATIONS

- Was either option helpful?
- In A, a long cantilever puts bending forces on the vertical support. How can this be avoided?
- In B, what sort of structure is needed to support the cantilever?
- Are the structures A and B balanced?
- Suggest ideas for solving the problems found in A and B. Record these in your workbooks or journals using notes and drawings.

### WHAT TO DO NEXT

Now try your ideas by modifying your bridge model.

### YOUR OBSERVATIONS

- Did your ideas work? If not, why not?
- How did your ideas differ from those in A and B?
- What other problems did you find and how did you solve them?

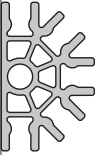

## SECTION I

# Skill Builder 7

## Student Inquiry Sheet

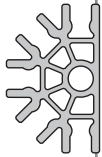

### SECTION I

#### KEEPING A RECORD

- Record and explain your results and observations through notes and drawings in your workbook or journal.

#### PART 3: Keeping things in balance

##### WHAT TO DO

- For this activity you will need to combine with another group because two cantilever models are needed.
- Join your models (A) Back-to-Back and (B) Face-to-Face (see diagrams below).
- Investigate the load bearing ability of your new designs.

##### YOUR OBSERVATIONS

- Why are these double cantilever bridge designs stronger than the single spans you investigated in Part 2?
- What changes would you need to make in these bridge designs to allow them to span a wider gap?

#### KEEPING A RECORD

- If available, use a digital camera to record your investigations.
- Outline drawings of models should be included, along with the descriptions and reasons for the decisions made by your team when solving the problems. Drawings should use correct symbols to show the types of forces acting on the main parts of the structure.

#### PART 4: Investigating How Structural Engineers Have Used Cantilevers to Make Real Bridges

##### CONSIDER THIS

In the previous activity you investigated how cantilevers can be used in bridge design. In this activity you will investigate how engineers applied these concepts to two very different types of bridges: in Scotland The Firth of Forth Bridge (cantilever) and the Dames Point Bridge in the USA (cable-stayed).

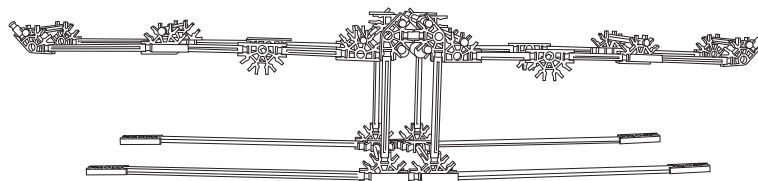

A. Back to Back

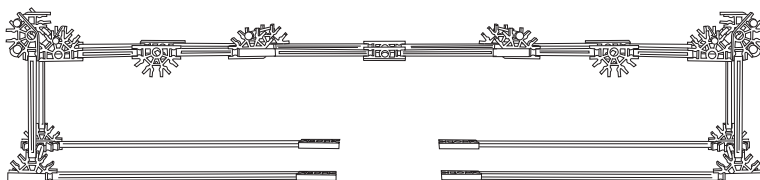

B. Face to Face



# Skill Builder 7

## Student Inquiry Sheet

- You will be working as part of a larger team to build and investigate what happens to your test model of EITHER the Firth of Forth Bridge OR the Dames Point Bridge.
- Once you have completed your investigation of the bridge you built you will swap with another team and repeat your investigation with the second bridge.
- At the end of both investigations, you should produce your own report on the two bridges to include the results of your investigations. You should also use the Internet to carry out research on both bridges so you can add relevant information to your report.
- It is important that you keep good notes of your investigations and observations. Use labeled drawings and, if possible, a digital camera to record and store information.

### MATERIALS

- 1 K'NEX Real Bridge Building set
- Building Instructions (Book 2) for all the team members.
- Assorted slotted masses (10-1000g)
- Rulers
- Top pan balances (optional)
- String

### WHAT TO DO

1. As a team, look through the Building Instructions to see the size of the task you have been set.
2. Decide how your team can construct your bridge in the time available.
  - You have the resources available – 4-6 people. How are you going to make best use of them?
  - Look at the building plans – can parts be sub-assembled separately?
  - Who can do sub-assembly work and who will do final construction?
  - What roles are needed to complete the task?
  - Does every one need to be involved in construction?
  - How will you organize the materials needed by those making the bridge?
  - Does every one know what they have to do?
3. Make the best use of your planning time and the resources the team has available. **Projects often fail because people simply fail to plan.**
4. Now build your bridge and investigate its load bearing ability, the forces acting on it, and how they affect the bridge. You should also consider where you might expect failure to occur.

### YOUR OBSERVATIONS

Identify:

- The maximum load your bridge can support at the middle of the central span. Note where and how any failure in your bridge structure occurs.

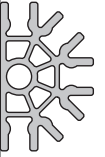

## SECTION I

# Skill Builder 7

## Student Inquiry Sheet

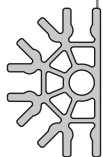

### SECTION I

- How does your K'NEX bridge model behave when loaded in different positions – in the middle, at either end, at the center of each pier or tower?
- Where might you expect failure to take place? Did your bridge behave as expected?
- Identify the forces that act on your model when under load and how they affect it?
- In your investigation of the **Firth of Forth Rail Bridge** identify the main structural members that are under compression and tension. What would happen if members were removed from A or B?

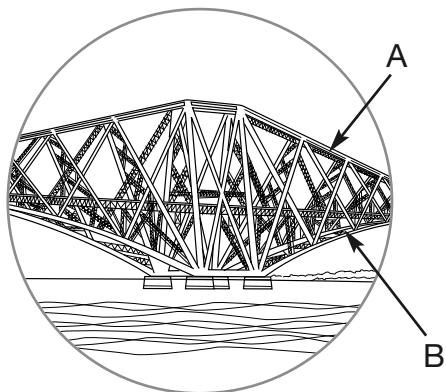
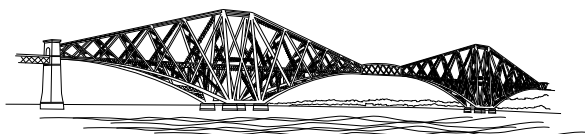

- In your investigation of the **Dames Point Bridge** identify the main structural members that are under compression and tension. What would happen if members are removed from A

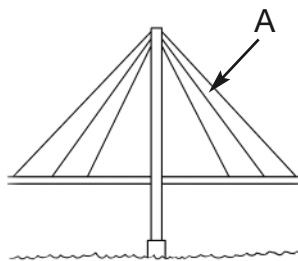

- How did the bridge designer eliminate the effects of bending forces that may cause structural failure?
- Do any parts of the structure move? How are these potentially disastrous problems solved in the real bridge design?
- Would you use your K'NEX design to make a full-scale construction? Explain your reasons.
- How are cantilevers used in each of the designs?
- How did the location/site of your bridge influence the design? What other factors may have had an influence on the design of your bridge?
- Compare the construction of your K'NEX bridge model with that of the real bridge. Use photographs obtained from the K'NEX Building Instruction booklets or from approved Internet web sites.
- *Photographs of a cantilever bridge collapse, the Koror-Babeldaob Bridge, may be seen on <http://www.ketchum.org/bridgecollapse.html>.*



# Skill Builder 7

## Student Inquiry Sheet

### EXTENDING THE INVESTIGATION

Carry out research on the two bridges using some of the links below. This type of research will provide you with some additional facts/statistics and photographs with which to analyze each bridge and its construction. Some areas you may want to investigate:

- The design challenges caused by the physical conditions of the site and how they were solved.
- The types of forces acting on the bridge and how the design takes them into account.
- Why this particular type of bridge design was chosen for this location.
- Both bridges are like giant seesaws. How do the bridge designs take into account loads moving across them?
- The challenges facing the bridge construction team and how they were solved.
- Why is the main bridge span of the Dames Point Bridge slightly arched and not straight? What does the arch add to the structural strength of the bridge?
- The alternative designs that were considered and why they were rejected.
- If, in your opinion, the bridge is a successful structure and your reasons for this opinion.

The following general Internet web sites are useful for research and photographs.

[www.howstuffworks.com](http://www.howstuffworks.com)

[www.brantacan.co.uk](http://www.brantacan.co.uk)

<http://encyclopedia.thefreedictionary.com/Cable-stayed%20bridge>

Firth of Forth Rail Bridge web sites:

[http://www.pbs.org/wgbh/buildingbig/wonder/structure/firth\\_of\\_forth.html](http://www.pbs.org/wgbh/buildingbig/wonder/structure/firth_of_forth.html)

*Background information and statistics.*

<http://www.pre-engineering.com/resources/forth/forthbridge.htm>

*Photographs of the bridge, including its construction.*

Dames Point Bridge web sites:

<http://www.bridgepros.com/projects/DamesPoint/DamesPoint.htm>

*Historical and factual information, plus links to other sites with photographs of the bridge design.*

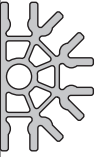

## SECTION I

# Skill Builder 8

## Student Inquiry Sheet

### Investigating Suspension Bridges

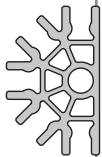

#### SECTION I

#### CONSIDER THIS

Suspension bridges have been used for thousands of years. From simple footbridges still used in many parts of the world today to superstructures thousands of meters long, a suspension bridge is in fact a simple structure. A rope **spans** a **gap** and a beam is suspended from the rope. What could be simpler?

In this activity your team (a group of 4-6) will be investigating the basic concepts that lie behind the technology of suspension bridges.

From earlier investigations you know that long beam bridges do not produce rigid structures. You can push the beam up from underneath using a large number of **columns** or **piers**, as in the Chesapeake Bay Bridge-Tunnel, or pull up from above, as in cable-stayed bridges like the Dames Point Bridge. It is not always possible, however, to apply similar solutions in locations such as San Francisco Bay, U.S.A. or the Humber Estuary, U.K., so an alternative – the suspension bridge – is used when dealing with very wide barriers like these.

**Safety Note:** Please wear safety glasses as you undertake these investigations.

#### MATERIALS

- K’NEX Real Bridge Building set
- Building Instructions booklet: Book 2
- Scissors
- String (this is in addition to the string that comes with the set)
- Slotted masses (20g-500g)
- Spring scale (optional)

#### WHAT TO DO FIRST

1. You will be making a simple suspension bridge. The towers of your bridge can be constructed using the building instructions for those of the K’NEX Golden Gate Bridge model (Book 2, Page 35-40: Steps 1-14).
2. You will also need to construct a beam from K’NEX material that is approximately 120 cm long. For this you can use Rods of any size. (It is suggested however, that you make your beam no wider than the length of a yellow Rod.)
3. Divide the building project up among the team members. For example, one person could make the parts shown in Steps 1-14 while someone else can be assigned Steps 15-20 and so on.
4. Once the towers are built you will need to make the following small modification in order to attach your beam. The person responsible for Step 8 should probably be assigned to do this:

# Skill Builder 8

## Student Inquiry Sheet

- Insert a green Rod on either side of the uppermost yellow Connector.
- Add another yellow Connector on either side of the original one.
- You should now have 3 yellow Connectors in a row, joined by 2 green Rods.
- The Rods forming the ends of the beam can then be passed through the holes of the yellow Connectors. You can add some black Clips to hold the Rod ends in place as you carry out your experiments.

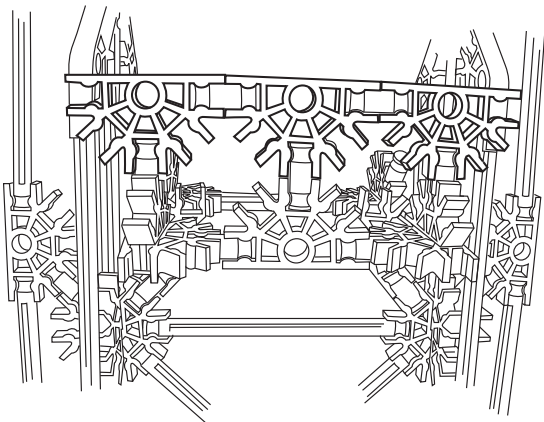

5. You have now created a **simply supported beam bridge**.

### WHAT TO DO NEXT

6. Add a small load to the center of the span and observe what happens (a) to the beam and (b) to the towers.

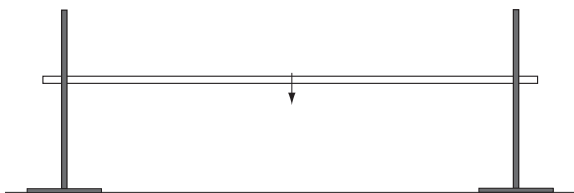

Record your observations and explanations through notes and drawings in your workbook or journal. Consider how you might overcome the problems you observed.

7. Will a cable-stayed bridge solution work for a very long beam bridge?  
Try the following:

- Carefully remove the ends of the beam from the yellow Connectors and then balance the beam so it rests on top of the row of 3 Connectors in each tower.
- Tie string to the mid point of the beam and either feel the force needed to return the beam to a horizontal position or use a spring scale to measure the force needed.

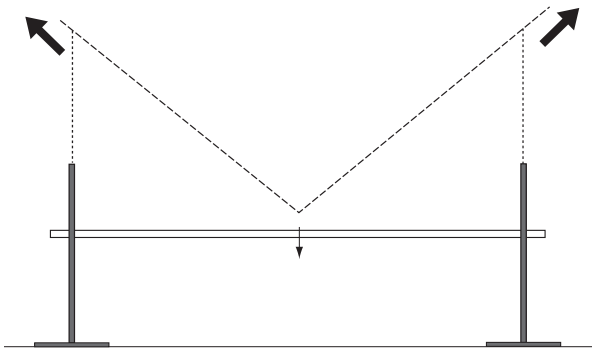

- Look at the position of your hands. This will give you an idea of the height of the towers needed to make a cable-stayed bridge.
- Compare the length of the bridge with the height of your hands (the height of your cable-stayed bridge tower) remembering that in reality your bridge

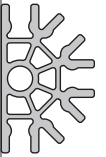

## SECTION I

# Skill Builder 8

## Student Inquiry Sheet

may be over 3000 meters long with a single span of over 1500 meters.

- Is it a practical solution to construct a tower this height? Explain the reasons for your response.

### Now Do This

8. (a) Connect the tops of the two towers using string (A) from your K'NEX Real Bridge Building set, **but do not cut it, as it will be needed for other activities.**

(b) Use a separate piece of string (B) to connect the cross cable with the beam bridge. This vertical cable is called a **hanger**.

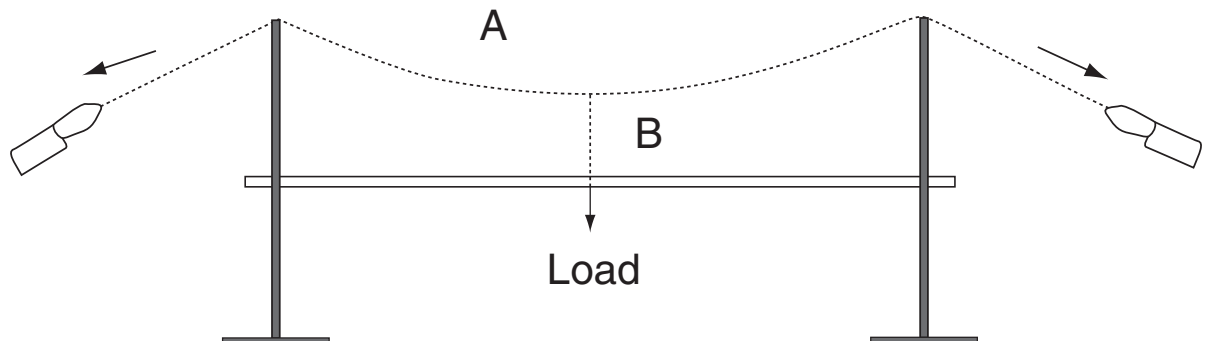
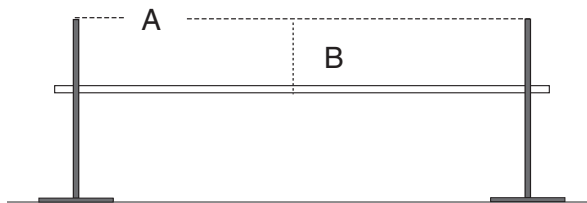

### YOUR OBSERVATIONS

Observe what happens to your simply supported beam bridge and the towers.

- Is simply attaching a cable to the tops of the towers and suspending the beam from it the solution?
- What happens?
- What changes would you make to this bridge design, to make it a more practical design, capable of supporting both live and dead loads? Include drawings of your ideas in your report.

### FINAL STEPS

9. Untie the string (cable) from the towers and place each end over the top of the towers (do not tie it to the tops); team members should hold each end of the string. Connect a hanger to the bridge span.
10. Team members at each end of the bridge should pull on the free ends of the string until the beam bridge becomes horizontal again.

# Skill Builder 8

## Student Inquiry Sheet

### YOUR OBSERVATIONS

Observe what happens to your simply supported beam bridge and the towers now.

- Is one central hanger enough to support the beam?
- What might happen to your beam bridge if a load was placed halfway between the central hanger and a tower? Try it and see.
- How would you modify your design to solve any problems observed?
- What types of forces are acting on (i) the towers, (ii) the main cable and (iii) the hangers?
- How are the main cables anchored in real suspension bridges?
- What do you think might happen to the Golden Gate Bridge if one of the main cables broke?

### KEEPING A RECORD

- Using the correct technical vocabulary, record and explain your observations and findings through notes and drawings in your workbook or journal. Make use of directional arrows to show

**compression:** → ←

and **tension:** ← →

in your models.

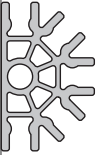

## SECTION I

## Case Study

# Case Study of a Bridge Design

### THE CASE STUDY

Designed as a collaborative activity, groups of 4-6 students develop their knowledge and understanding of structures through investigations of famous bridges (one per group) and the factors that influenced their design and construction.

Each group will be expected to plan their research activities, identify specific tasks and roles, use the Internet for searches within chosen parameters, and make use of desktop publishing, or other word processing software, to produce individual written reports. The group will be expected to prepare and present their findings to the class, making use of appropriate presentation software and multimedia hardware.

This case study complements Applying the Concept – Investigating Real World Structures from Skill Builder Activities: 5B, 6B, 7B, 8B and the Bridge Construction Project – An Exercise in Teamwork, Planning and Implementation, in which a project team of 4-6 students plan and organize their activities to complete the construction of a large-scale bridge model within a limited time scale. The case study would be based on one of the bridges used in the bridge construction project. Such a synergistic approach allows students carrying out the case study to observe the testing of a model of the bridge they are investigating and to incorporate their observations into their reports.

As two different bridges can be constructed and investigated simultaneously using the K'NEX Real Bridge Building set, it is possible for a whole class to be involved in both activities at the same time.

### SUGGESTED TIME REQUIREMENTS

2 x 70 minute sessions to allow for planning, implementation, preparation.

1 x 35 minute session for group presentations of results.

### INTRODUCTION

Structures come in all shapes and sizes but they share one thing in common - they are designed and built to support loads. These loads may be static or dynamic, or a combination of the two.

Dynamic loads produce much greater forces than static loads and their effects must be assessed when designing and making structures, even those whose functional life is intended for supporting static loads. For example:

- Electricity pylons not only carry the weight of power cables, but additional forces may impact them during storms, when high winds and snow increase the loading on the structure.
- Furniture, such as chairs and beds, must be able to withstand not only the weight of people sitting on them, but also the shock forces of people sitting down or even children playing on them.
- Large structures, such as bridges and tall buildings, are also subject to the effects of high winds, or snow and ice build-up, in addition to all the other loads they have to support.

The failure to fully account for the dynamic effects of a constant wind led to the famous collapse and failure of the Tacoma Narrows Bridge, known as “Galloping Gertie”, in 1940.



## SECTION II





## Case Study

All structures are designed and constructed according to specific engineering concepts. To be successful, a structure must not only be able to withstand compression, tension, bending, torsion and shear, but also environmental forces due to high winds, snow and ice build-up, water currents, earthquakes and other seismic events.

Using the design and construction of a bridge as a case study enables students to learn how an understanding of the forces acting within a structure is essential to its overall success. Bridges are like any other product – they must fulfill a practical need. While products such as DVD players, mobile phones, or clothing fulfill the personal needs of the individual, bridges often fulfill the economic needs of a community and a country. What, for example, was the need for The Astoria Bridge in Oregon, USA, particularly as it gained the nickname of “the Bridge to Nowhere” during its construction? Why was there a need for a second river crossing of the Severn Estuary between Bristol and South Wales in the UK? Why construct The Queen Elizabeth Bridge across the River Thames at Dartford, UK when there is a road tunnel under the river, or build a bridge across 16 kilometers of the Oresund Sound to link Denmark with Sweden, when high-speed ferries already connect the two countries?

A study of the design of structures encompasses subjects outside the requirements of Design and Technology. Students studying the history of the 19th Century will read about the impact of the Industrial Revolution on human development. In the USA and in Victorian Britain, engineers developed innovative design solutions to make larger and larger structures as new products and technologies became available. In Britain, engineer-entrepreneurs such as Derby, Brunel and Telford designed and made giant structures from wrought iron. Innovative structures such as the Menai Suspension Bridge, the Clifton Suspension Bridge, railroads, and large ocean going ships made from iron, such as the Great Eastern, are examples of their work. In the USA,

engineers such as Roebling (Brooklyn Bridge) extended the frontiers of bridge construction by designing and building structures that stretched for over a mile in length.

Geography students will benefit from investigating reasons for the location of bridge structures, their intended purpose, the needs they meet, the associated transport infrastructure and their impact on human and other environments.

Just as the design, manufacture, use and disposal of many familiar products have an environmental impact, so environmental issues must also be taken into consideration when bridges are designed and constructed. Modern bridges need thousands of tons of concrete, steel and miles of access roads. What impact will the extraction of the raw materials and their production have on the environment and local wildlife habitats?

Engineers must consider a wide range of factors when they embark on a new bridge design and construction project. These include considerations about its location and site, what it must carry, the distance it must span, weather and other environmental conditions, safety considerations, aesthetics, cost factors and budget and time constraints. These factors, in turn, may also affect the choice of materials used to construct a bridge. The combination of these factors makes the design and construction process a challenging enterprise.

The demands for longer and longer bridges also required the implementation of new construction methods and the use of new materials to keep the important balance between the weight of the bridge and its structural strength and stiffness. Not all were successful. Learning from catastrophic bridge failures such as the Quebec Bridge in Canada (collapsed in 1907 and 1916) helped modern structural engineers develop improved and safer designs.



## SECTION II

# Case Study



## SECTION II

### CASE STUDY EXAMPLES

The K'NEX Real Bridge Building set provides examples of 7 famous bridge designs, some of which demanded innovative engineering solutions to solve the problems caused by the location and the need to safely span longer and longer barriers. Included in the set are the following categories of bridge:

- Chesapeake Bay Bridge (USA)  
*Extended Beam Bridge*
- Sydney Harbour Bridge (Australia)  
*Arch Bridge*
- Dames Point Bridge (USA)  
*Concrete Cable-stayed Bridge*
- Tower Bridge (U.K.)  
*Moveable Bascule; Suspension Bridge*
- Firth of Forth Rail Bridge (U.K.)  
*Cantilever Bridge*
- Astoria Bridge (USA)  
*Truss; Cantilever Bridge*
- Golden Gate Bridge (USA)  
*Suspension Bridge*

### OBJECTIVES

Students will learn to:

- Work as part of a team.
- Use the Internet for searches with specific parameters.
- Evaluate information.
- Develop oral, written and graphic presentation skills.

### The Task

The team **investigates** and **evaluates** the design of one of the bridges in the K'NEX Real Bridge Building set. Alternatively, students might select a bridge within or close to the area in which the school is located.

At the end of the investigation each member of the group should prepare a written report and/or contribute to a group multimedia presentation describing the key features of their chosen bridge design.

As part of this activity students should identify:

- The structural concepts used in the bridge design and how they were applied.
- The types of forces acting on the bridge and how the design accommodated them.
- The materials used in the construction and why they were used in preference to other available materials.
- The properties that made these materials suitable for use in the bridge design.
- Why it was built on its present site.
- Why the particular type of bridge design was chosen for this site.
- The challenges facing the engineers when creating the design for the bridge and how they were solved.
- The alternative designs that were considered and why were they rejected.
- How the bridge was constructed, the problems encountered and how the engineers solved them. How the construction engineers prevented it from collapsing before it was completed.
- The need for the bridge and whom it serves.

# Case Study

- How the building of the bridge impacted the local environment. For example:
  - Were the local communities impacted by increased or reduced traffic/quality of life issues; what effects did its construction have on businesses in the area?
  - What was the impact of the construction of the bridge and new access roads on local habitats and wildlife? Did air and noise pollution from vehicles increase?
- If, in their opinion, the bridge is a successful structure. They should be prepared to justify their answer.

## THE PRESENTATION

Students would be expected to use a range of Information Technology skills, resources and software in the preparation and presentation of their research.

In taking part in this task students would be expected to:

- Work as part of a team.
- Use the Internet for searches with specific parameters.
- Use word processing, desktop publishing or other presentation software to prepare their report/ make their presentation.

## CONCLUSION

Once every group has presented their findings, engage the whole class in a discussion about the advantages and disadvantages of each type of bridge. As a concluding activity you may want to have the students assess their knowledge by playing the 'Build a Bridge' game found on the PBS Nova web site referenced below.

## USEFUL INTERNET WEB SITES

<http://www.matsuo-bridge.co.jp/english/bridges/index.shtm>

*This site gives offers background information, facts and statistics about different bridge designs.*

<http://www.pbs.org/wgbh/nova/bridge/resources.html>

<http://www.pbs.org/wgbh/nova/bridge/gamesans.html>

*These two sites provide an interactive resource for students to test their understanding of bridges by determining the best bridge design for a particular location. Both sites are linked.*

<http://pbs.org/wgbh/amex/goldengate/>

*A companion site to the PBS television program on the construction of the Golden Gate Bridge. A script of the TV program is available, together with a wide range of other teaching resources, including facts about the construction, bridge math, 1930's engineering techniques, people involved in the construction and a section on how to use the site in a multidisciplinary classroom (civics, geography, history and economics.)*

[www.brantacan.co.uk](http://www.brantacan.co.uk)

*An excellent resource site that addresses every type of bridge. Some of the information can be very detailed and technical, but if you have a question about bridges you will probably find an answer here. An excellent selection of photographs.*

[www.howstuffworks.com/bridge](http://www.howstuffworks.com/bridge)

*A good introductory site for information on the main bridge types.*

<http://www.ketchum.org/bridgecollapse.html>

*Contains references to a number of bridge collapses, video footage of the Tacoma Narrows Bridge collapse and graphics of the Tay Railway Bridge disaster.*



# Construction Project

## *A Bridge Construction Project*

*An Exercise in Teamwork, Planning and Implementation*



### SECTION III

#### INTRODUCTION

In the Bridge Construction Project a team of 4-6 students must plan and organize their activities to complete the construction of a large-scale bridge model within a limited amount of time. They will effectively role-play the job of construction engineers, who must transfer 2-D designs into 3-D reality.

Two bridges can be constructed simultaneously from one Real Bridge Building set, enabling 8-12 students to be involved in this activity at any one time. On completion of their bridge construction, the project team will be expected to make a presentation to the class, reviewing their plan, how it worked, and the lessons learned.

By including a presentation element the student teams will need to identify those parts of the project that are sequential and dependant on each other and other parts, such as the presentation, that can run in parallel to the main construction project. Resources can be allocated accordingly.

This activity also complements Applying the Concept – Investigating Real World Structures from Skill Builder Activities 5B, 6B, 7B, 8B, as well as Section II: Case Study of a Bridge Design – a collaborative investigation for 4-6 students, in which the group develops their knowledge and understanding of structures through an investigation of the design of a famous bridge and the factors that influenced its design and construction. If run together, additional time may be needed for presentations and class discussion.

#### THE BRIDGE CONSTRUCTION ASSIGNMENT

The task for the project team is to devise and implement a plan to complete the construction of a bridge within a strict time limit. Maximum time allowed for the actual construction phase = 45 minutes. Effective planning is essential. Many activities conform to the 80:20 rule which states that 80% of the effort is spent in the planning and 20% in the execution.

This activity is intended to help students develop important life skills through a project that encourages them to:

- Analyze a problem.
- Identify the key elements of the problem and the order in which they must be done.
- Evaluate the resources available.
- Plan the most effective use of their resources and the time available in order to successfully complete the task they have been set.

At the end of the activity, students are encouraged to evaluate their own and the team's performance and to learn from their experiences.

If they have not done so before, students should be encouraged to investigate the load bearing ability of their bridge. Additional time can be provided for this after the 45 minute construction deadline.

For example, you may want to ask your students to investigate and find answers to the following:



Investigate and identify:

- The maximum load your bridge can support at the middle of the central span. Note where and how any failure in your bridge structure occurs.
- How your K'NEX bridge model behaves when loaded in different positions – middle, at either end, at the center of each pier or tower.
- Where you might expect failure to take place. Did your bridge behave as expected?
- Identify the forces that act on your model when under load and how they affect it.

## THE BRIDGES

The K'NEX Real Bridge Building set provides models of real bridges that require from 260 to 1000 parts to make.

### Book 1:

Chesapeake Bay Bridge – 267 parts  
Sydney Harbour Bridge – 673 parts  
Dames Point Bridge – 515 parts  
Tower Bridge – 790 parts

### Book 2:

Firth of Forth Rail Bridge – 500 parts  
Astoria Bridge – 747 parts  
Golden Gate Bridge – 1051 parts

Building times for individual bridges vary but it could take one person, working alone, 3 or more hours to complete. To accomplish the task of building one of the bridges in a 45 minute target time, students will need to use team work, and their analytical, planning and organizational skills.

With good planning and working effectively as a team, a group of 4 - 6 students should be able to reduce the actual construction time needed to build their bridge. To help them, some preparatory lesson time may be needed

to cover aspects of project planning including the use of **flow diagrams** and **Gantt Charts** to plan, manage and monitor progress. The use of a digital or video camera can also assist students record progress and information that may be later used in presentations or when using desktop publishing software to write reports.

## OBJECTIVES

For students to learn:

- Planning and team building skills.
- Project management skills.
- Problem solving skills.

## SUGGESTED TIME REQUIREMENTS

Maximum 5 x 35 minutes lesson periods to allow for planning, implementation, preparation and presentation of results.

For example:

- Session 1: 70 minutes: Planning, preparation of plans, identification and allocation of roles.
- Session 2: 70 minutes:  
5 minutes: Final preparations and organize resources.  
45 minutes: Construction time.  
15 minutes: Testing and recording .  
5 minutes: Contingencies.
- Session 3: 35 minutes  
Group presentations.

Activities might include:

### Session 1 (70 minutes): Planning and Preparation

- Analysis of K'NEX Real Bridge Building plans to formulate a construction plan. For example: The K'NEX building plans are sequential but is one step dependant upon another? Are there sections of the bridge that can be built simultaneously?

# Construction Project



## SECTION III

- Student teams should:
  - Identify sections of the bridge that can be made as sub-assemblies.
  - Identify tasks for team members; match their skills to the tasks to be performed and the order in which the tasks must be done. Teams could ask themselves: *Who is good at construction? Who has the best IT skills? Who has the best time keeping and organizational skills?*
  - Identify who is to be responsible for the overall management of the project and to see that the project is kept on schedule.
  - Investigate the logistics of supplying construction workers with the correct components when needed; make lists of the K'NEX components needed for each stage in preparation for the actual construction of the bridge in the following lesson.
  - Use flow diagrams or Gantt Charts to aid planning. (The use of Gantt Charts may not be suitable for younger aged students).

*Two sets of Real Bridges Building Instructions are available but additional photocopies of specific sub-assemblies may be needed. These are available on the accompanying CD-ROM and should be printed out ahead of time. An overhead projector or PowerPoint facilities may be required for group presentations.*

### **Session 2 (70 minutes): Implement the Construction Plan**

5 minutes:  
Allow students time prepare the sorting and distribution of components from the central stores – The K'NEX Real Bridges Building Set – ready for their construction teams to use.

45 minutes:  
Construction time.

15 minutes:  
Testing their bridge design: See: *Skill Builder Activities 6B, 7B and 8B: Applying the Concept – Investigating Real World Structures.*

5 minutes:  
Contingencies – possible time for finalizing presentation details.

### **Session 3 (35 minutes):**

- Group presentations. Maximum time allowed for each presentation – 7 minutes.
- Feedback and class discussion.

## **IMPROVING LEARNING PERFORMANCE**

Students should reflect on their performances both as individuals and as teams. They should evaluate their plan, how well it worked, problems encountered and solutions arrived at, how decisions were made and what lessons were learned.

- How well did they plan for this activity? What steps did they miss?
- What problems occurred during the construction phase and how did they solve them?
- How well did they use their resources to meet the construction timescale and to prepare a presentation at the same time?
- How well did they match the skills required for specific tasks with individuals' skills.
- What would they do differently next time?

## Working as Design Engineers

### The K'NEX Pedestrian Bridge Project

#### INTRODUCTION

Many students believe that a design and create assignment ends when they can demonstrate that their product works. In real life, however, the process of getting a product to its target market can often be lengthy.

Professional designers and engineers operate in a world in which their designs must not only work and be aesthetically pleasing, but they must sell at the right price, in the right market, and generate a good profit for all those who have invested in the development and production. For a company to be successful it must be able to gain repeat sales, often from the same customer – their satisfaction is critical to a company's profitability.

Moving from a single prototype to full production is a complex process requiring much planning. In addition, the manufacturing process itself must be cost effective if it is to meet the financial requirements of the business that markets and sells the product.

Nowhere is this more important than in the development of a large structure such as a bridge or tunnel, especially as there is sometimes only one chance to get it right. Mistakes in the construction industry can be very expensive to rectify. For example, the cost of removing the excessive movement in London's Millennium Bridge across the River Thames – a pedestrian bridge, first opened in 2000 – was \$7.5million. Controlling manufacturing or construction costs, therefore, is one essential requirement for any successful business.

This activity is designed to give students an opportunity to experience for themselves some

of the issues faced by professional engineers. Depending on the ages, aptitudes and interests of the students, they can also make use of spreadsheet software to cost and model their plans, use computer aided design (CAD) software to produce simple working drawings, and use planning software to create flow diagrams or make use of Gantt planning charts. This activity builds upon the skills acquired by students in previous sections.

#### THE K'NEX PEDESTRIAN BRIDGE CHALLENGE

A whole class activity involving project teams, each comprised of approximately 4 - 6 students. Each team adopts the role of a Design Engineering company.

#### OBJECTIVES

The K'NEX Pedestrian Bridge Challenge is intended to help students learn and develop a range of key skills as they work on a design and technology project in which they take a product – a bridge – from the design phase through to its final construction. Their bridge must meet cost and time parameters laid down in the product specification.

#### The key skills identified include:

- *Communication* – through the generation and exchange of ideas, with peers and teachers, concerning the design of a bridge that meets the specifications.



# Design Project



## SECTION IV

- *Numeracy* – through measurement, estimation and costing of activities and materials needed for the construction of a structure designed by the students.
- *Planning* – to take into account the relative costs of materials, labor and time when deciding how best to use available resources to successfully complete a design and create task.
- *Team building* – within a large group project, to generate and discuss their own and other people’s ideas. To deal with conflicting views and to agree on the best way to work together to achieve a common goal.
- *Problem solving* – not only solving specific design and technology problems, but also to be able to deal with and resolve conflicting needs resulting from the project.
- *Information Technology* – in the reviewing of information, preparation and presentation of their work, and processes involved in completion of a bridge design task.
- *Improving on learning performance* – at the end of the project students will be encouraged to evaluate the whole process and to identify where and how they might improve their overall performance.

### TIME REQUIRED

The project can take place over the equivalent of one 35 minute and two 70 minute sessions. Part of an additional lesson may be needed to complete the review and evaluate their performance.

#### First session

35 minutes:

Understanding the design specifications and initial brainstorming session.

#### Second session

70 minutes:

Finalizing bridge design, drawing plans, costing materials and planning construction.

#### Third session

70 minutes:

Construction, testing, review and presentation of company results.

### MATERIALS

- K’NEX Real Bridge Building set(s)
- Copies of the Design Engineering Guidelines for Students
- Copies of the Suppliers Price List/Order Form for each team
- Weights or masses (10g-1000g)
- Flip chart paper or large sheets of paper

### SCENARIO

The development of new roads throughout the region has identified a need for a number of pedestrian bridges.

The company that can design and successfully construct a bridge that meets the

- customer’s design specifications
- at the lowest cost
- and can complete on time,

can expect to be rewarded with additional contracts for similar projects in the future. These contracts will provide security for the company and its workforce for many years ahead.



# Design Project

## THE RULES

Each company will receive the same set of design specifications. The design teams within the company must:

- Design a structure to meet the specifications.
- Complete construction within 30 minutes.
- Prepare a presentation to market/sell their design to the customer (maximum of 3 slides for each presentation and maximum 5 minutes presentation time). No extension to the 5 minute time will be allowed.
- The presentation should also include the company's estimate for the total cost of the project to the customer. Designing time is not to be included in the construction cost estimates.
- Shareholders expect a minimum profit of 20% of the total construction costs: i.e. Project cost = construction cost + profit (20% of construction cost)

## BONUS PAYMENTS

Completion of construction ahead of schedule: \$100 per minute.

The total value of bonus payments will be added to the estimated company profit. If, however, the structure fails to meet the design specifications, no bonus payments will be made and penalties will apply.

## PENALTIES

- Overrun of contract: \$150 per minute.
- Structure fails to meet the design specifications: 50% of the value of the contract.

The total value of the penalties will be deducted from the company profit on the contract.

## CONTRACT AWARD

This will go to the company whose design meets their customer's specifications and requirements and makes the greatest profit margin.

## EXTENSION IDEAS

Students could be asked to build a *factor of safety* into their designs and have their bridges tested until failure occurs.

The activity can be extended to the use of other materials including balsa wood or other suitable woods that require a different set of construction skills, knowledge and understanding of materials.



## Design Project

# Design Engineering Student Guidelines

## The K'NEX Pedestrian Bridge Project

### Sunrise County Public Bid # 78680 Job specifications for a pedestrian bridge

1. The bridge should consist of two towers connected by a pedestrian walkway.
2. A clear area for traffic to pass under the bridge will be a box 14cm high by 60cm wide. No part of the bridge structure may pass through this clear area.

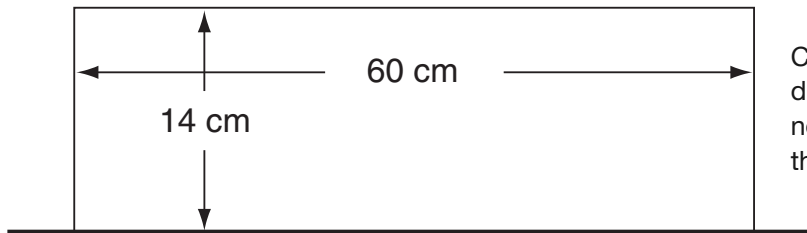

Clear area for traffic dimensions. These are not the dimensions of the bridge itself.

3. The minimum width of the pedestrian walkway will be 6.5cm.
4. The completed bridge must be capable of supporting a load of 2 kg placed anywhere on the pedestrian walkway. (When being tested, the bases of each tower may be supported because in the real world these would be set in concrete footings which would stop them moving outwards.)
5. The bridge must remain level when loaded.
6. Foot access to the bridge walkway need not be included in the design at this stage.

### SUNRISE COUNTY PEDESTRIAN BRIDGES PROJECT: GUIDELINES FOR COMPANIES

The development of new roads throughout the region has identified a need for a number of pedestrian bridges.

The company that can design and successfully construct a bridge that meets the

- customer's design specifications
- at the lowest cost
- and can complete on time (30 minutes construction time)

can expect to be rewarded with additional contracts for similar projects in the future.

These contracts will provide security for your company and your workforce for many years ahead.

# Design Project

## TIME SCALE

- You have three sessions (the first of 35 minutes and two of 70 minutes) to complete the design, planning and construction of a pedestrian walkway bridge.
- Your company design team can use the first two sessions to research and develop ideas, design, cost, and plan how your company can construct the footbridge within the time limitations. In the final session your company will build and test your bridge design.

## COST FACTORS

- Your company will be given a supplier's price list for the K'NEX building materials that you will need to purchase before starting construction.

## Organizing your Resources

### I: Designing and planning phase (35 minutes)

#### WHAT TO DO FIRST

1. Review the job specification for the pedestrian footbridge and the rules of the competition.
2. Make sure that all members of the company understand what has to be accomplished and the rules of the competition. If unsure ask your teacher to explain.
3. Good planning is the key to any successful project. During this phase it is up to your team to look at the resources available – human as well as material – and to plan how best they can be used to complete tasks within the time available.

## WHAT TO DO NEXT

4. As a team, decide what type of bridge will meet the job specification. Remember that the company has only 30 minutes of construction time.
5. Brainstorm ideas:
  - Use a flip chart (if available) or a large piece of paper to write down everyone's ideas before discussing them one by one.
  - Every person on the team has a valid contribution to make and every idea should be evaluated on its merits.
  - Remember to check with the job specifications to make sure your ideas keep on track.
6. Finish the session with an agreed outline bridge design to take forward to the next planning session.

### II: Designing and planning phase (70 minutes)

#### WHAT TO DO

1. Finalize the decision about the bridge type you will design.
2. Assigned tasks to company members.
3. Produce plan drawings (front, side and top elevations).
4. Decided how the bridge will be constructed.
5. Produce estimates for the K'NEX building material costs.
6. Present the bridge design and cost estimates for the project to the customer (your teacher) before the end of this session. Remember other teams also need to do this, so book an appointment with your customer at a time that best suits your company.



## SECTION IV

# Design Project

## SUGGESTIONS

- Keep your presentation short and to the point – your customer is very busy and does not have much time.
- Look at the design specifications and see what the customer is really looking for from your design.
- Although the maximum time allowed is 5 minutes; plan for 3 minutes as presentations often overrun.

## ESTIMATING THE BRIDGE'S TOTAL CONSTRUCTION COSTS

Your company must take the following into account:

1. Cost of materials.
2. Construction costs.
3. Company profit.

### 1. Estimating Cost of Materials

- K'NEX components as per **suppliers price list** (make sure you obtain this from your teacher)
- Plastic decking (track) – sold at \$100 per piece.
- Card stock – sold at \$10 per cm.
- String – sold at \$30 per 30 cm.

An order form for K'NEX building materials must be completed and the cost estimated by the end of this session. This order form will be used to collect the K'NEX components from your supplier (your teacher) at the start of the next session.

#### **Note:**

(i). *If you need additional components to complete your bridge after submitting your order, then prices are doubled.*

(ii). *Any components left over at the end of construction must be sold back to the supplier at half the original price.*

### 2. Estimating Construction Costs

- \$300 per minute per person in the construction workforce.

**Note:** *The whole team need not be involved in the construction of the bridge. Construction costs are high but construction time is short (30 minutes) and the project cannot be too expensive.*

**Plan for construction.** *Can any parts of the bridge be sub-assembled before being put into the final bridge construction?*

- To calculate the labor costs, first estimate the construction time in minutes. Then multiply the construction time (in minutes) x labor cost per minute x number of people involved in the bridge construction.

For example:

$$20 \text{ minutes} \times \$300 \times 4 \text{ people} = \$24,000$$

### 3. Estimating Company Profit

- Shareholders in your company expect a minimum profit of 20% of the total construction costs.

i.e. Project cost = construction cost + profit (20% of construction cost)

If the total construction cost of the bridge is \$100,000.

$$\begin{aligned} \text{Project cost} &= \$100,000 + \$20,000 \\ &= \$120,000 \end{aligned}$$

#### **Note: The Successful Company**

The contract for the project will be awarded to the company whose design meets its customer's specifications and requirements and makes the greatest profit.

# Design Project

## Ideas to help you work through the planning sessions

1. Make sure you all understand the design brief. Clarify with the customer - your teacher - if uncertain.
2. Brainstorm/discuss/research/test possible designs for your bridge. Remember every team member's ideas should be considered. Write all the ideas down on a large piece of paper first and then discuss them. Always keep the job specification in mind.
3. Use your K'NEX Real Bridge Building components to model and communicate ideas within the team. Can you use, or modify, the plans for bridges you have previously constructed for this project?
4. Draw up plans for your bridge design. Ask yourselves:
  - a. Can it be built in the time available?
  - b. Can components that are needed be identified?
  - c. Do the plans allow your team to prepare a cost estimate for the materials?
  - d. Can everyone in the construction team understand the plans and their own role in the project?
  - e. Will the completed structure function as intended?
  - f. Are there potential weak areas?
  - g. Does it meet the measurement specifications?
5. Look at the total time available and the tasks you need to complete in that time. List the tasks and set a time to complete each task. Can different tasks be done at the same time? Which tasks depend on another being completed first? Sequence the tasks in the order they need to be done – use a flowchart or timeline for this.
6. You may find that the total time needed to complete tasks is greater than the actual time available in class. You may therefore need to agree to allocate (delegate) specific tasks to members of the team.

For example: the whole team may be involved in designing the bridge but planning how to construct the bridge in 30 minutes and the preparation of the company presentation and calculation of project cost may need to be done at the same time. Separate teams can work on these tasks. Allow a few minutes for the whole team to be informed about each team's work.
7. Someone could be given the responsibility of making sure team tasks are completed on time or negotiating additional time from other company members if needed.
8. Where separate teams are involved in carrying out different tasks, a member of each team should be responsible for keeping the team to its allotted time.
9. Always allow time for tasks to overrun. Keep some time free at the end, just in case it is needed.
10. When planning how to construct your bridge, consider if all, or only some, team members need to be involved. *Remember you need to keep construction costs to a minimum but still need to get the job done in time – beware of penalty costs!*
11. Consider the following:
  - Who will make the plan drawings?
  - What roles need to be fulfilled and what are their responsibilities? For example: Project Manager to make sure work is completed on time and meets specifications; Logistics Manager to make sure all the supplies are in the right place at the right time; Construction workers to actually make the bridge.



# Design Project

- Do team members' skills match the job they are required to do?
- Can some team members be involved in sub-assembly work while a small number complete the construction?

## III: Construction Phase (70 minutes)

### RECOMMENDED TIME ALLOCATION

#### 15 minutes (maximum)

- Final check of design and K'NEX components list.
- Collect K'NEX components from supplier and prepare site for the start of construction.
- You are allowed to have all your K'NEX components laid out for easy and fast access to help the bridge construction.
- You are not allowed to pre-assemble any parts of the bridge before construction starts.
- Once construction has started, pre-assembly of bridge parts can take place.

#### 30 minutes (maximum)

- Bridge construction.
- No materials can be left on the building site. All unused materials must be returned to the supplier and their value worked out.

#### 25 minutes (maximum)





















- Test bridges.
- Complete profit/loss calculations.
- Review and evaluate performance and lessons learned from the project.
- Present company results and conclusions to class.



## SECTION IV



## IV. Suppliers Price List

A PART IDENTIFICATION	B COLOR	C COST/ITEM	D QUANTITY ORDERED	E SUB-TOTAL COST [ column (c) x column (d) ]
	Purple	\$10		
	Black	\$10		
	Light Blue	\$10		
	Black	\$10		
	Orange	\$20		
	Light Gray	\$20		
	Green	\$50		
	Yellow	\$50		
	Blue	\$70		
	Gray	\$40		
	Green	\$10		
	White	\$20		
	Blue	\$40		
	Yellow	\$60		
	Red	\$80		
	Gray	\$90		
	Light gray	\$5		
	Bright blue	\$5		
	Black	\$100		
	Transparent White	\$20		
	(String - any color)	\$30 per 30 cm.		
<b>Card Stock</b>	(Paper - any color)	\$10 per cm.		
NAME:			TOTAL COST	

**Note:**

- ï Returned items will be bought back at 50% of the original cost.
- ï Additional items will be charged at double the original cost.

# An Interdisciplinary Activity for Real Bridge Building



SECTION V

## INTRODUCTION

The purpose of this activity is to provide an interdisciplinary activity for the Real Bridge Building Set. It will allow science and mathematics teachers, or technology and mathematics teachers, to work together to enhance students' understanding of math and science concepts, as they relate to suspension bridges.

The materials have an additional benefit in that they enable students to see that sometimes their estimations are grossly incorrect and that with a little forethought, they can arrive at more plausible approximations. This is especially true when students make estimates of distances and heights based on photographs and recall.

This activity also highlights some of the civil engineering mathematics that come into consideration when a suspension bridge is planned.

## MATERIALS

- K'NEX model of the Golden Gate Bridge
- Rulers and pencils
- Graph paper: 4-5 squares to the inch (8.5" by 11")
- Pictures of suspension bridges

## BACKGROUND

Suspension bridges include a long length of cable, normally made from steel in the largest of suspension bridges and rope or vines in the simplest of suspension bridges. These cables sag as they extend from one bridge tower to the next. The cable sags into a shape that

mathematicians call a **parabola**. Since the cable forms a known mathematical shape, we can use mathematics to investigate some of the measurements and characteristics of the cable and the entire bridge system.

**NOTE:** In reality, a suspension cable hangs in a shape that is termed a **catenary** rather than a true parabolic curve. When the suspenders are in place and the total weight of the bridge is brought to bear on the suspension cable, the curve of the suspension cables approximates the shape of a parabola closely enough for the purposes of this activity and application of the mathematical formulas for a parabola.

The standard formula for a parabola is:

$$y = ax^2 + bx + c$$

Where: (adapted with bridge terminology)

**y** = height of a point along the parabola (In the case of bridges, the height of the tower.)

**a** = amplitude of the parabola (The larger the number, the steeper the sides of the parabola.)

**b** = the distance the center of the parabola is to the left or right of the "y" axis on a graph

**c** = the distance the center of the parabola is above or below the "x" axis on a graph

**x** = the distance from the center of the bridge to the center of a tower



Thus:

If we draw the deck, towers, and cables of a suspension bridge to scale on graph paper, the best location for the (0,0) point of the graph is at a point along the road deck that is just above or below the center of the parabola formed by the sagging cable.

In that case, the value of “b” becomes (0) since the center of the parabola falls on the “y” axis of the graph. Therefore the expression “bx” can be dropped from our formula since “0” times “x” is always “0.” This makes our math, graphing, and analysis much easier.

In the case of the suspension bridge, the amplitude of the parabola is very low. The distance between the towers is many times greater than the height of the towers. During the course of this investigation, students may begin to realize that camera angles and other factors, that lead them to imagine that the towers of a suspension bridge are extremely high in comparison to the distance between the towers of the bridge, can be very deceiving. If the students solve the formula for a suspension bridge with a known span, they can determine the height of the towers of that bridge. If the students know the height of the towers of a bridge and the amplitude of the parabola, they can determine the span of the bridge.

In this activity, students will do the following:

- Bring their knowledge of parabolas from mathematics class.
- Draw their estimation of the shape of a suspension bridge to scale on a graph paper using a known span for their bridge.
- Determine the accuracy of their estimation by examining the extent to which their drawing is reasonable.
- Determine the amplitude of several famous suspension bridges.
- Determine the height of the towers of several famous suspension bridges.

### ACTIVITY 1 THE PROCESS

Provide each student with a sheet of graph paper. Inform students that they are going to draw a scale model of the Golden Gate Bridge, using graph paper.

- Instruct students to hold their graph paper in a landscape direction.
- Have them draw a line across the page five squares above the bottom of the page. This line represents the deck of the Golden Gate Bridge and for graphing purposes it represents the “x” axis of their graph.
- Inform students that they are going to attempt a scale drawing of the bridge, from one tower to the other.
- Ask the students to provide the length of the span (distance between the towers) for the Golden Gate Bridge or provide the distance for them (4200 ft.) The activity can be done in meters or feet. Many new mathematics books include examples in their text for completing problems in a variety of systems so students realize that concepts hold true no matter which measurement system they use.
- Student should determine a value that represents the distance from one line on their graph paper to the next so that they can draw a scale Golden Gate Bridge that extends nearly to the edges of their paper. Depending on the number of squares to the inch, each square could represent 100 or 150 feet.
- Instruct students to find the center of the line representing the deck of the bridge. Instruct students to draw a light, vertical line from their mark to the top of the page. This line represents the “y” axis on their graph.



## Interdisciplinary Activity



### SECTION V

- Have students find the location of the towers of the bridge. Using their scale, how many squares must they count to the left and to the right of the lightly drawn “y” axis to mark the location of the towers of the bridge? If their scale is 100 feet for each vertical line on the graph paper, they will count 21 lines to the left of the centerline and 21 lines to the right of the centerline to place marks that identify the location of the towers. If their scale is 150 feet for each vertical line on the graph paper, they will count 14 vertical lines to the left and right of the centerline to place their marks for the towers.
- Tell students that they are to estimate the shape of the parabola that extends between the towers and sags toward the deck. (You may ask them why they had to place a mark on the road deck to represent the center of the span. They should respond that this represents the point where the cable comes closest to the deck of the bridge.)
- After the students have drawn their parabolas, ask them to draw towers that extend to the height they have chosen for their drawing.
- Using their original scale of the distance between graph lines representing 100 or 150 feet, have the students calculate and report the heights they have determined for the towers of the bridge in their drawing. Generally, students make drawings with tower heights that are far too high. Some students will have values extending into the thousands of feet. Begin a discussion of what they think a reasonable value would be for the tower height and see what information and past experience they bring to the discussion. In most instances, the students readily admit that they have guessed too high for the towers.

- Using the scale of one square representing 100 or 150 feet, have students call out the height above the roadway they have drawn for the center of the parabola. (Answers will generally be in the hundreds of feet. Refer back to pictures of the bridge to determine if these values are realistic.) In most cases, the bottom of the cable’s parabola is somewhere between 5 and 30 feet from the deck of the bridge.
- After discussing the students’ drawings, suggest that students draw a second line on their graph paper that they feel is a more realistic representation of the height of the towers and the distance to which the cable sags above the road deck.

### ACTIVITY 2

#### THE PROCESS

- Review the drawings with the students and inform them that there is a formula that they can use to find the shape of the parabola for any suspension bridge:

Standard parabola formula for a suspension bridge

$$y = ax^2 + c$$

Where:

**y** = height of the tower

**a** = amplitude of the parabola (The larger the number, the steeper the sides of the parabola.)

**c** = the distance the center of the parabola is above or below the “x” axis on a graph

**x** = the distance from the center of the bridge to the center of a tower

## Interdisciplinary Activity

- Complete the formula for the Golden Gate Bridge to determine the height of the towers. (A value of 0.000112 has been determined for the amplitude of the parabolic curve of the Golden Gate Bridge.)

$$\begin{aligned}y &= \text{height of the tower} \\a &= 0.000112 \\c &= 5 \text{ feet} \\x &= 2100 \text{ feet (1/2 the 4200 foot span)}\end{aligned}$$

$$\begin{aligned}y &= .000112 (2100)^2 + 5 \text{ feet} \\y &= .000112 (4410000) + 5 \text{ feet} \\y &= 494 + 5 \text{ feet} \\y &= 499 \text{ feet}\end{aligned}$$

- Ask students to solve the general formula to determine the formulas to find:

“x” – or 1/2 the span of the bridge  
“a” – or the amplitude of the parabola  
“c” – or the height above the deck the sag of the parabola reaches

Students with appropriate math skills should arrive at the following formulas:

$$X = \sqrt{\frac{y - c}{a}}$$

$$a = \frac{y - c}{x^2}$$

$$c = y - ax^2$$

- Break the class into four or eight groups.
- Inform the students that each group is going to mathematically determine a

different characteristic of the parabola that is formed by the cable on the K'NEX Golden Gate Bridge.

- The groups will be able to come up to the front of the room and measure three of the values for their bridge and then be allowed to return to their seats to see if they can solve for the missing value.
- As the teacher, you will need to monitor the model as the students make their measurements to ensure they do not measure the value they are trying to determine.
- Provide the students with small data sheets (shown below,) to assist in this process and to help students with their data collection. Help them to use a consistent measurement system across the four groups.

Group # 1  
y = unknown  
a = \_\_\_\_\_  
x = \_\_\_\_\_  
c = \_\_\_\_\_

Group # 2  
y = \_\_\_\_\_  
a = unknown  
x = \_\_\_\_\_  
c = \_\_\_\_\_

Group # 3  
y = \_\_\_\_\_  
a = \_\_\_\_\_  
x = unknown  
c = \_\_\_\_\_

Group # 4  
y = \_\_\_\_\_  
a = \_\_\_\_\_  
x = \_\_\_\_\_  
c = unknown

(The students can complete this activity with their bridge or a model at the front of the room.)



## SECTION V

## Interdisciplinary Activity

### ASSESSMENT

#### MAT ACTIVITY

- Ask the students to get into groups of four and to sit around a table.
- Provide each group with chart paper or a sheet of easel paper.

Arrange the paper as shown so that there is a triangle-like shape in front of each student. They should put their name in this space.

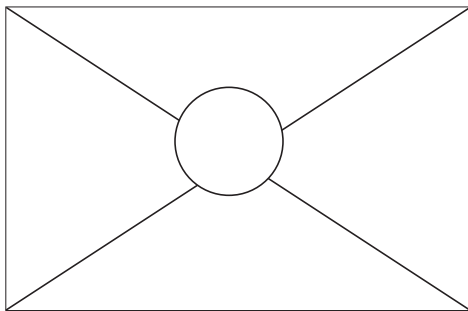

- Have each student list in the space what they have learned from their investigations of the Golden Gate Bridge and parabolas. They should provide as much detail as possible.
- When students have been given sufficient time to respond, ask the group to discuss what they have written and then to put information they agree upon in the circular space in the center of the page.

**NOTE:** The outside of the page presents you with an understanding of what individual students gathered from the instructional session. The center of the page gives you a sense of changes to individual thought as a result of discussions with the student's work group. You may wish to assign both an individual and a group grade to this activity.

### EXTENSION ACTIVITIES

This same activity can be repeated for other famous suspension bridges around the world. Students can easily find data as to the spans of various suspension bridges on the Internet, in textbooks, or in other reference materials.

A similar activity can be used to study arch bridges. Since the parabola of an arch bridge is curved downwards rather than upwards, the formula will need to include a negative value to invert the curve. In the case of the arch bridge, the students would generally be determining the height of the arch above the surface of the water.



## SECTION V

# Glossary

*The following is intended as a glossary for the teacher. The age of your students, their abilities, their prior knowledge, and your curriculum requirements will determine which of these terms and definitions you introduce into your classroom activities. They should be used to formalize and clarify the operational definitions your students develop during their investigations.*

## **BRIDGES:**

**Bridge:** A structure that provides a way across a barrier. Something that connects, supports, or links one thing to another.

**Beam:** A horizontal structure that is subject to bending.

**Arch Bridge:** A bridge having a curved structure. The arch design provides strength by exerting force downwards and sideways against the abutments.

**Bascule Bridge:** A hinged bridge that acts like a seesaw. Sections can be lifted using weights as a counterbalance.

**Beam Bridge:** The simplest type of bridge. It is made from a rigid, straight structure resting on supports (piers, columns, towers) at either end.

**Cable-stayed Bridge:** A modern design of bridge in which the deck is supported by cables directly attached to towers.

**Cantilever Bridge:** Similar to the beam bridge, this design derives its support from counterbalanced beams meeting in the middle of the bridge rather than from supports at either end. The two arms of the beam are called cantilevers.

**Suspension Bridge:** A type of bridge in which the deck hangs from wires attached to thick cables. The cables themselves pass over towers and are securely anchored in concrete anchorages.

**Truss Bridge:** A type of beam bridge, reinforced by a framework of girders that form triangular shapes.

## **LOADS AND FORCES:**

**Load:** The distributions of weights on a structure. (See also Dead Load and Live Load below).

**Force:** A push or pull. In the case of bridges, force is applied to the bridge in the form of a load.

**Stresses:** Forces that tend to distort the shape of a structure or a structural member. For example, compressive stresses tend to shorten a member while tensile stresses tend to stretch it.

**Stress:** A measure of the force applied to a material and depends on the surface area over which the force is being applied.  $Stress = Force/Area$  and is measured in  $N/m^2$  or pascals (Pa)

**Strain:** A measure of the change in length of a material caused by stress. Strain is the result of stress.  $Strain = Change\ in\ length/original\ length$



# Glossary



**Young's modulus or modulus of elasticity of a material:** Compares the amount of strain produced in a material with the stress that produced it. *Young's modulus (E) = Stress/strain*

A strong or stiff material will only have a short change in length (steel), whereas a weaker or more elastic material (rubber) will produce a large change in length. Steel will have a much higher value for Young's modulus than rubber.

**Compression:** A force that tends to shorten, push or squeeze a structure.

**Tension:** A force that tends to lengthen or stretch part of a structure.

**Torsion:** The strain produced when a material is twisted.

**Reaction (Reactive force):** For every action there is an equal and opposite reaction (Newton's Third Law of Motion). If an external force is applied to a structure the internal forces within the structure push back with equal strength against the external force. When the forces are balanced the structure is said to be stable.

**Shear:** A force that acts to move a material in a sideways motion.

**Strength of a structure:** Determined by the magnitude of the external forces needed to make it fail.

**Strength of a material:** Determined by the amount of stress that is needed to make it fail.

**Symmetry:** An arrangement that is balanced and equal on opposite sides of a central dividing line.

**Buckle:** A condition that occurs when structural members bend under compression.

**Dead Load:** The weight of a bridge's structure.

**Live Load:** The weight of traffic using the bridge.

**Environmental Loads:** Additional loads on a structure caused by wind, currents, rain, snow and ice build up, earthquakes and other seismic events.

## BRIDGE FEATURES:

**Abutment:** The mass of rock or concrete at either end of an arch bridge that keeps the ends of the arch securely in place.

**Anchorage:** Foundations/concrete blocks into which the cables of a suspension bridge are secured.

**Beam:** A rigid, horizontal component of a bridge.

**Brace:** A support used to strengthen and stiffen structures.

**Cable:** A bundle of wires used to support the decking of a suspension bridge or a cable-stayed bridge.

**Caisson:** A temporary structure used to keep out water during construction of the piers' foundations.

**Cantilever:** A beam that is supported at one end only.

**Decking:** The surface of the bridge that serves as a walkway, roadway or railway.



# Glossary

**Engineer:** A professional who researches and designs bridges and other structures. There are many types, including civil, structural, and environmental engineers.

**Framework:** A skeletal arrangement of materials that give form and support to a structure.

**Frame structure:** Made by joining together a number of parts or members – for example a K'NEX model.

**Girder:** A strong, supporting beam.

**Handrail or Guardrail:** A safety feature added to the sides of the bridge's deck to prevent people, animals or vehicles from falling from the bridge.

**Keystone:** The final wedge-shaped piece placed in the center of an arch that causes the other pieces to remain in place.

**Member:** A part of a frame structure.

**Obstacle:** Something that stands in the way or acts as a barrier.

**Pier:** A vertical support for the middle spans of a bridge – a column, tower or pillar, for example.

**Pulley:** A wheel used for hoisting or changing the direction of a force.

**Ramp:** An inclined section connecting the shore/banks/approach route to the deck of the bridge.

**Roadway:** The area of the bridge along which traffic travels; it rests on the decking.

**Span:** The section of the bridge between two piers.

**Support:** An object that holds up a bridge and serves as a foundation.

**Suspender:** A supporting cable for the deck; it is hung vertically from the main cable of the suspension bridge. Also known as a Hanger.

**Strut:** A structural support under compression.

**Tie:** A structural support under tension.

**Tower:** A tall, vertical support that carries the main cables of a suspension bridge and cable-stayed bridge.

**Triangulation:** The use of triangles to strengthen frame structures.

**Truss:** A framework of girders, some in tension and some in compression, comprising triangles and other stable shapes.

**Voussoir:** A wedge-shaped stone block used in an arch. (French: 'arch-stone.')

# Reading/Resources

## Additional Recommended Reading/ Resources for Students

- Billington, David P. **The Tower And The Bridge.** Princeton, NJ: Princeton University Press. 1985. ISBN 069102393X.
- Dunn, Andrew. **Bridges (Structures).** Thomson Learning. 1993. ISBN 1568470282.
- Gordon, JE. **Structures: Or Why Things Don't Fall Down.** De Capo Press. 2003. ISBN 03068128355.
- Harris, David W. **The Newspaper Truss.** BaHa Enterprises. 2001. ISBN 0967549515 (CD-ROM)
- Haslam, Andrew et al. **Building (Make It Work! Science).** Two-Can Publishers. 2000. ISBN 1587283514 (Reading age: 9-12 years.)
- Johman, Carol A. et al. **Bridges: Amazing Structures to Design, Build and Test.** Williamson Publishing. 1999. ISBN 1885593309.
- Kaner, Etta. **Bridges.** Toronto: Kids Can Press, 1995. ISBN 1550741462. (Reading age: 9-12 years.)
- Kaner, Etta. **Towers and Tunnels.** Toronto: Kids Can Press, 1995. ISBN 1550742183. (Reading age: 9-12 years.)
- Macaulay, David. **Building Big.** Boston, MA: Houghton Mifflin Company. 2000. ISBN 0395963311.
- Oxlade, Chris. **Bridges (Superstructures Series).** Austin, TX: Raintree Publishers. 1997. ISBN 0817243313.
- \_\_\_\_\_. **Bridges (Building Amazing Structures Series).** Heinemann Library. 2000. ISBN 1575722755.
- Salvadori, Mario. **The Art of Construction.** Chicago, IL: Chicago Review Press. 1990. ISBN 1556520808.
- Williams, David. **Truss Fun.** BaHA Enterprises. (2nd edition.) 2004. ISBN 0967549523.
- Wilkinson, Philip. **Building (Eyewitness Books).** London: Dorling Kindersley Publishing Inc. 2000. ISBN 0789466074.



## Useful Web Sites

**<http://www.brantacan.co.uk/>**

A valuable resource site with detailed information on all aspects of bridge design and construction. It offers an excellent selection of photos and diagrams, which can be used in the classroom.

**<http://www.icomos.org/studies/bridges.htm>**

This site provides a library of bridge types from around the world. Heavy on text and very detailed, it serves as a good reference source.

**[http://eduspace.free.fr/bridging\\_europe/index.htm](http://eduspace.free.fr/bridging_europe/index.htm)**

A useful educational web site with links to other sites. It has informative ideas for lessons and activities.

**[www.pbs.org/wgbh/buildingbig/bridge/](http://www.pbs.org/wgbh/buildingbig/bridge/)**

This web site offers an excellent interactive section where Forces, Loads, Shapes and Materials can be investigated.

**<http://www.pbs.org/wgbh/nova/bridge/>**

A companion web site to the US television series, "Super Bridge." A useful source of information on bridge building, with interactive sections.

**[http://www.bbc.co.uk/history/british/victorians/iron\\_bridge\\_01.shtml](http://www.bbc.co.uk/history/british/victorians/iron_bridge_01.shtml)**

This site offers animated and interactive sections on building an arch and the construction of the Iron Bridge at Coalbrookdale, England – the first iron bridge. You may need to download a free VRML plug-in or QuickTime to view these pages. Directions are provided.

**<http://pghbridges.com/basics.htm>**

A useful web site with simple line drawings and basic information on different bridge types.

**<http://www.bearwoodphysics.com/3schemproject3.3.12.htm>**

An excellent web site with many drawings and diagrams of different bridge types and the forces acting on them.