

# K'nex

**52** MODEL  
Building Set  
MODELE  
Jeu de construction

# IMAGINE™



Ages  
**7-12**

13465

(EN) CONTENTS

Hummingbird .....	6	Golf Cart.....	10
Camel.....	6	Sailboat.....	12
Praying Mantis .....	7	Skyscraper .....	13
Centipede.....	7	Dinosaur .....	14
Windmill.....	8	Steamroller.....	16
Butterfly.....	9	Bomber .....	20

**K'NEX BUILDING BASICS**

**1. Start Building**

To begin your model, find step 1 and follow the numbers. Each piece has its own shape and color. Just look at the pictures, find the pieces in your set that match and then connect them together. Try to face your model in the same direction as the instructions while you build. The arrows show you where the parts connect, but not all connections points have arrows. Faded colors show you this section is already built.

**2. Spacers**

There are places in your model where you need to use spacers. Be sure to use the correct number of spacers shown in the instructions.

**3. Connectors**

You can slide these special connectors together. Push tightly until you hear a "click". Pay close attention to the instructions and position them horizontally or vertically exactly as they are shown.

**4. Parts List**

Before you start building, be sure to compare the parts in your set with the parts list here. If anything is missing, call or write to us using the information on the back cover. We are here to help you!

4.

3.

1.

2.

(FR) **CONTENUS**

Colibri .....	6
Chameau.....	6
Mante de Prière .....	7
Centipède.....	7
Moulin à Vent .....	8
Papillon .....	9
Chariot de Golf.....	10
Voilier.....	12
Gratte-ciel .....	13
Dinosaure.....	14
Rouleau Compresseur.....	16
Bombardier .....	20

**ESENCIALES DE CONSTRUCCIÓN K'NEX**

**1. Démarrer la Construction**

Pour commencer le modèle, trouver l'étape numéro 1 trouver les numéros. Chaque pièce a sa propre forme et sa propre couleur. Regarder les illustrations, trouve les pièces qui correspondent à l'illustration et les assembler. Pour vous faciliter la tâche, orienter le modèle dans le même sens que les instructions. Les flèches indiquent où les pièces s'assemblent, mais les points de raccordement n'ont pas tous des flèches. Les pièces de couleur délavées sont celles déjà assemblées.

**2. Espaceurs**

Il y a des endroits sur le modèle où des espaceurs sont nécessaires. S'assurer d'utiliser la bonne couleur et le nombre d'espaceurs indiqué sur les instructions.

**3. Connecteurs**

Vous pouvez assembler ces connecteurs tout à fait uniques en les faisant glisser l'un dans l'autre. Pousser fort jusqu'au « clic ». Lire les instructions attentivement et es positionner horizontalement ou verticalement, en suivant exactement les illustrations.

**4. Liste des Pièces**

Avant de commencer, s'assurer de comparer les pièces dans la boîte à la liste de pièces fournie ici. S'il manque quelque chose, nous téléphoner ou nous écrire en vous servant des informations figurant au verso de la notice. Nous sommes là pour vous aider !

(DE) **INHALT**

Kolibri .....	6
Kamel.....	6
Gottesanbeterin .....	7
Hundertfüßer .....	7
Windmühle.....	8
Schmetterling .....	9
Golfmobil .....	10
Segelboot.....	12
Wolkenkratzer .....	13
Dinosaurier .....	14
Dampfwalze.....	16
Bomber .....	20

**GRUNDLEGENDE  
BAUANLEITUNGEN FÜR K'NEX**

**1. Los Geht's mit dem Bauen**

Um mit dem Bauen deines Modells zu beginnen, suche die Nummer 1 und folge den laufenden Nummern. Jedes Teil hat seine eigene Form und Farbe. Schau dir einfach die Abbildungen an, such die Teile in deinem Bausatz, die so aussehen wie das, was du auf der Abbildung siehst und steck sie ineinander. Versuche, dein Modell beim Zusammenbauen so zu orientieren, dass es in die gleiche Richtung weist, wie es in den Anleitungen beschrieben und gezeigt wird. Blasse Farben weisen darauf hin, dass dieser Streckenabschnitt bereits zusammengebaut ist.

**2. Abstandsstücke**

An manchen Stellen in deinem Modell musst du Abstandsstücke einbauen. Achte darauf, die richtige Farbe und Anzahl von Abstandsstücken wie in der Anleitung gezeigt zu verwenden.

**3. Verbindungsstücke**

Blaue und silberfarbene verbindungsstücke haben besonders lange Schlitze. Wie du auf der Abbildung sehen kannst, lassen sie sich ineinander schieben. Achte beim Aneinanderfügen dieser Teile darauf, dass du ein Klickgeräusch hörst. Erst dann sind die Teile fest miteinander verbunden.

**4. Teileliste**

Bevor du mit dem Bauen anfängst, solltest du prüfen ob die Teile in deinem Bausatz mit denen auf dieser Teileliste übereinstimmen. Falls etwas fehlt, rufe uns an oder schreibe uns (siehe Rückseite). Wir sind für dich da!

(NL) **INHOUD**

Kolibrie .....	6
Kameel.....	6
Bidsprinkhanen .....	7
Duizendpoot.....	7
Windmolen .....	8
Vlinder .....	9
Golfkar.....	10
Zeilboot.....	12
Wolkenkrabber .....	13
Dinosaurus .....	14
Stoomwals .....	16
Bommenwerper.....	20

**BASISSTAPPEN VOOR K'NEX BOUWEN**

**1. Begin te Bouwen**

Om met je model te beginnen, vind eerst het nummer 1 en volg de nummers. Elk stuk heeft zijn eigen vorm en kleur. Kijk gewoonweg naar de afbeeldingen, vind de overeenstemmende stukken terug in je geheel en maak e aan mekaar vast. Tracht je model in dezelfde richting te plaatsen als de aanwijzingen terwijl je bouwt en monteert. De vervaagde kleuren duiden aan dat dit deel reeds is opgebouwd. Gelieve het nieuwe deel vast te koppelen op de plaats aangeduid door de pijlen.

**2. Tussenstukken**

In je model zijn er plaatsen waar blauwe en zilveren tussenstukken moeten toegevoegd worden. Verzeker je ervan de juiste kleur te gebruiken en tel ze zorgvuldig.

**3. Koppelstukken**

Er zijn blauwe en zilveren koppelstukken met speciale lange gleuven. Ze schuiven in mekaar zoals je kunt zien op de afbeeldingen. Duw deze onderdelen in mekaar tot je een "klik" hoort.

**4. Onderdelen Lijst**

Voordat u begint met bouwen, moet u de onderdelen vergelijken de set met de onderdelen lijst hier. Als er iets ontbreekt, bel of schrijf ons gebruik van de informatie op de achterkant. We zijn hier om u te helpen!

# 52

MODELS  
MODÈLES  
MODELLS  
MODELS

**1** PER WEEK!  
PAR SEMAINE!  
PRO WOCH!



For instructions of all these models go to [www.knex.com/instructions](http://www.knex.com/instructions) and enter code 13465.

Car les instructions de ces modèles vont à [www.knex.com/instructions](http://www.knex.com/instructions) et entrez dans le code 13465.

Für Anweisungen dieser Modelle gehen sie zu [www.knex.com/instructions](http://www.knex.com/instructions) und geben sie Code 13465 ein.

Voor instructies van deze modellen naar [www.knex.com/instructions](http://www.knex.com/instructions) en vul de code 13465.



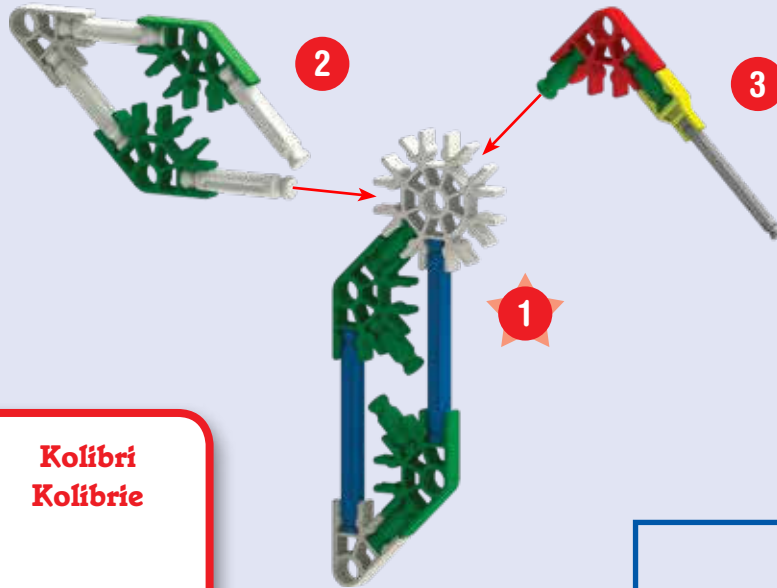

**Hummingbird**  
**Colibri**

**Kolibri**  
**Kolibrie**



**WARNING: CHOKING HAZARD – Small parts.**  
Not for children under 3 years.

**ATTENTION : RISQUE D'ÉTOUFFEMENT – Petite taille.** Ne convient pas aux enfants de moins de 3 ans.

**ADVERTENCIA: PELIGRO DE ASFIXIA – Piezas pequeñas.** No recomendado para niños menores de 3 años.

**ACHTUNG: ERSTICKUNGSGEFAHR – Kleinteile.** Nicht für Kinder unter 3 Jahren.

**AVVISO: PERICOLO DI SOFFOCARE – Pezzi piccoli.** Non adatto per bambini sotto 3 anni.

**AVISO: PERIGO DE SUFOCAÇÃO – Peças pequenas.** Não indicado para crianças menores de 3 anos.

**WAARSCHUWING: VERSTIKKINGSGEVAAR – KLEINE ONDERDELEN.** Niet voor kinderen onder 3 jaar.

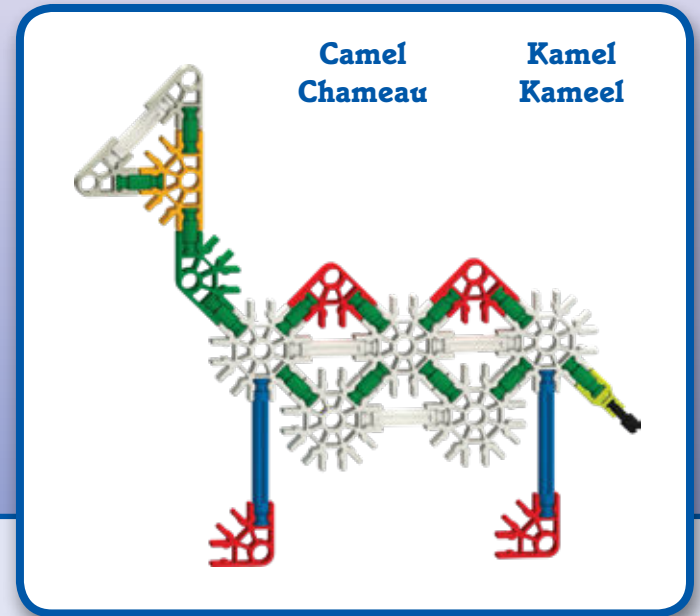

**Camel**  
**Chameau**

**Kamel**  
**Kameel**

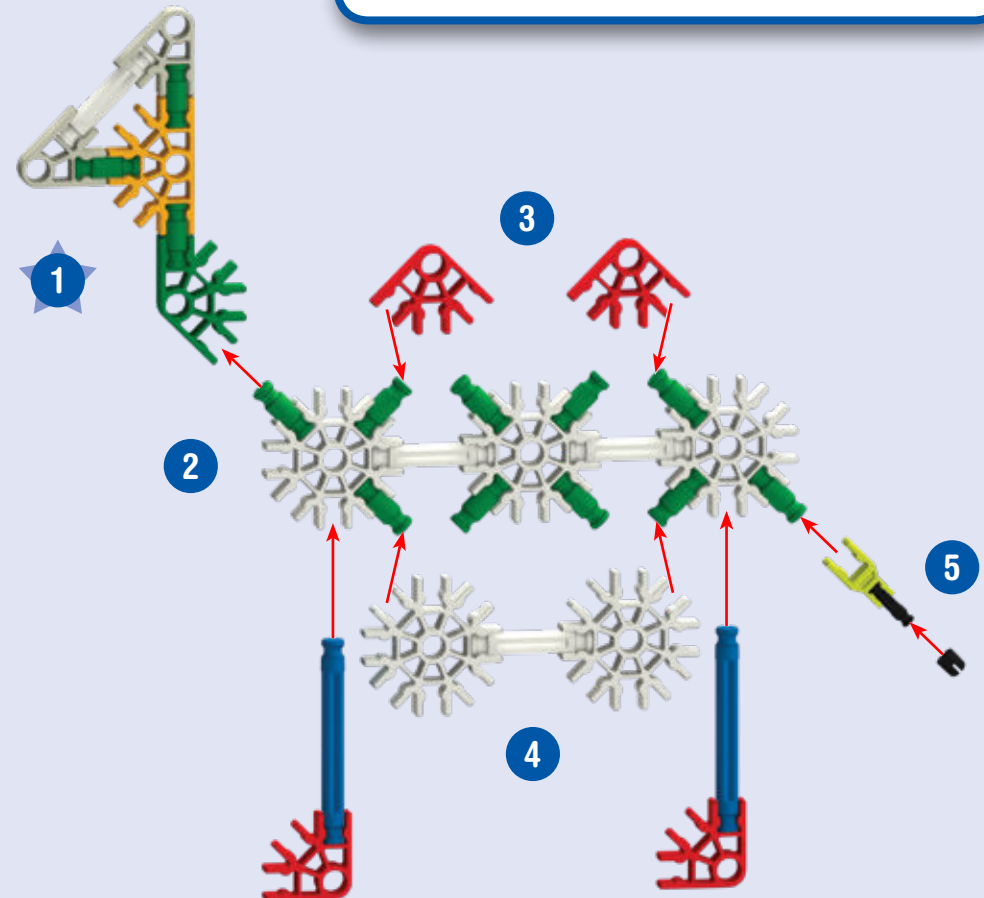

**Praying Mantis** **Gottesanbeterin**  
**Mante de Prière** **Bidsprinkhanen**

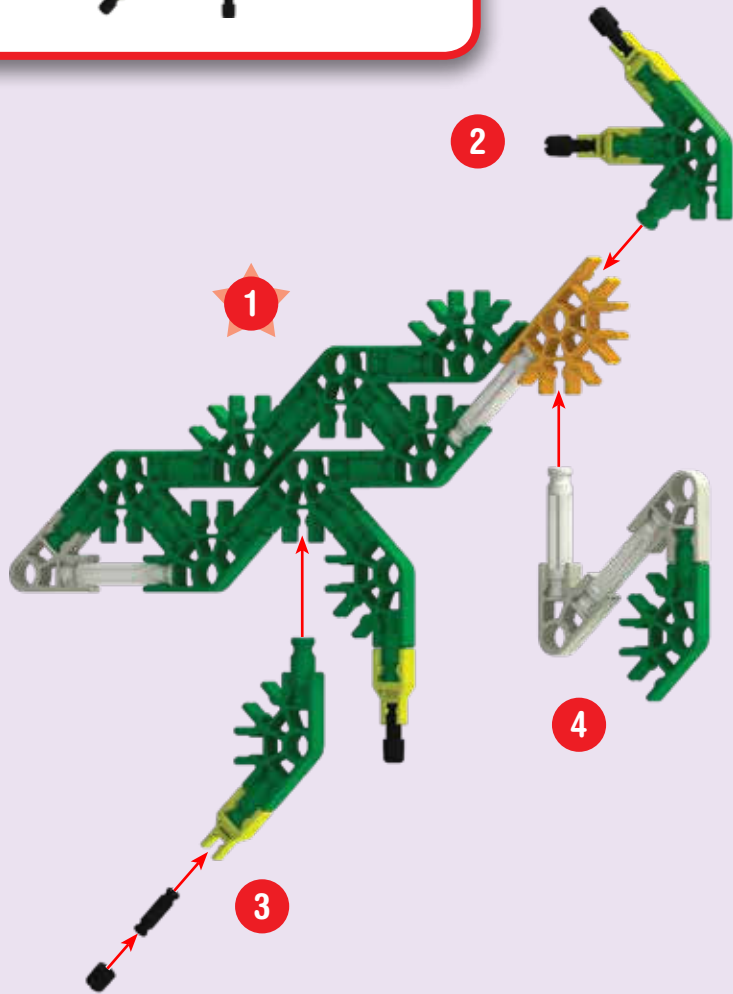
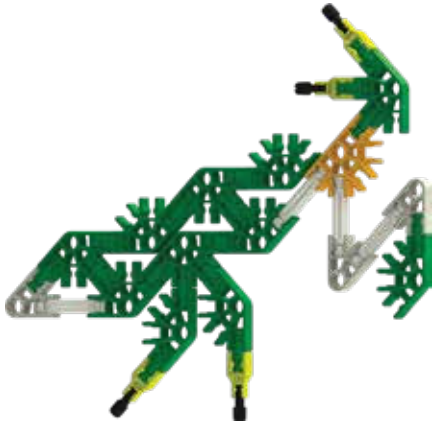

**Centipede**  
**Centipède**  
**Hundertfüßer**  
**Duizendpoot**

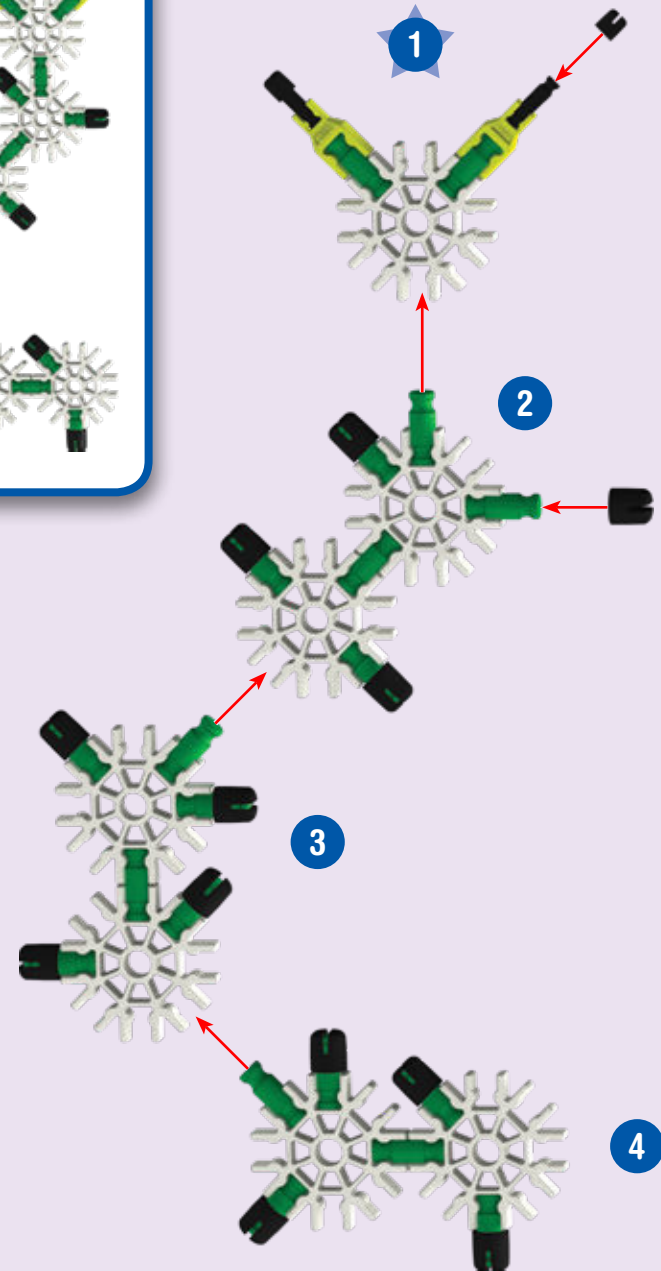
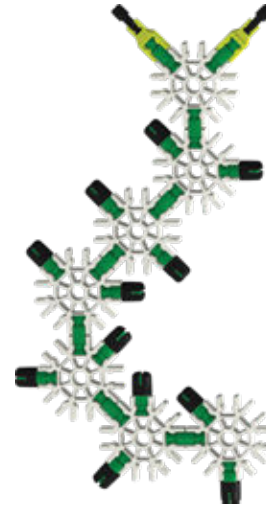

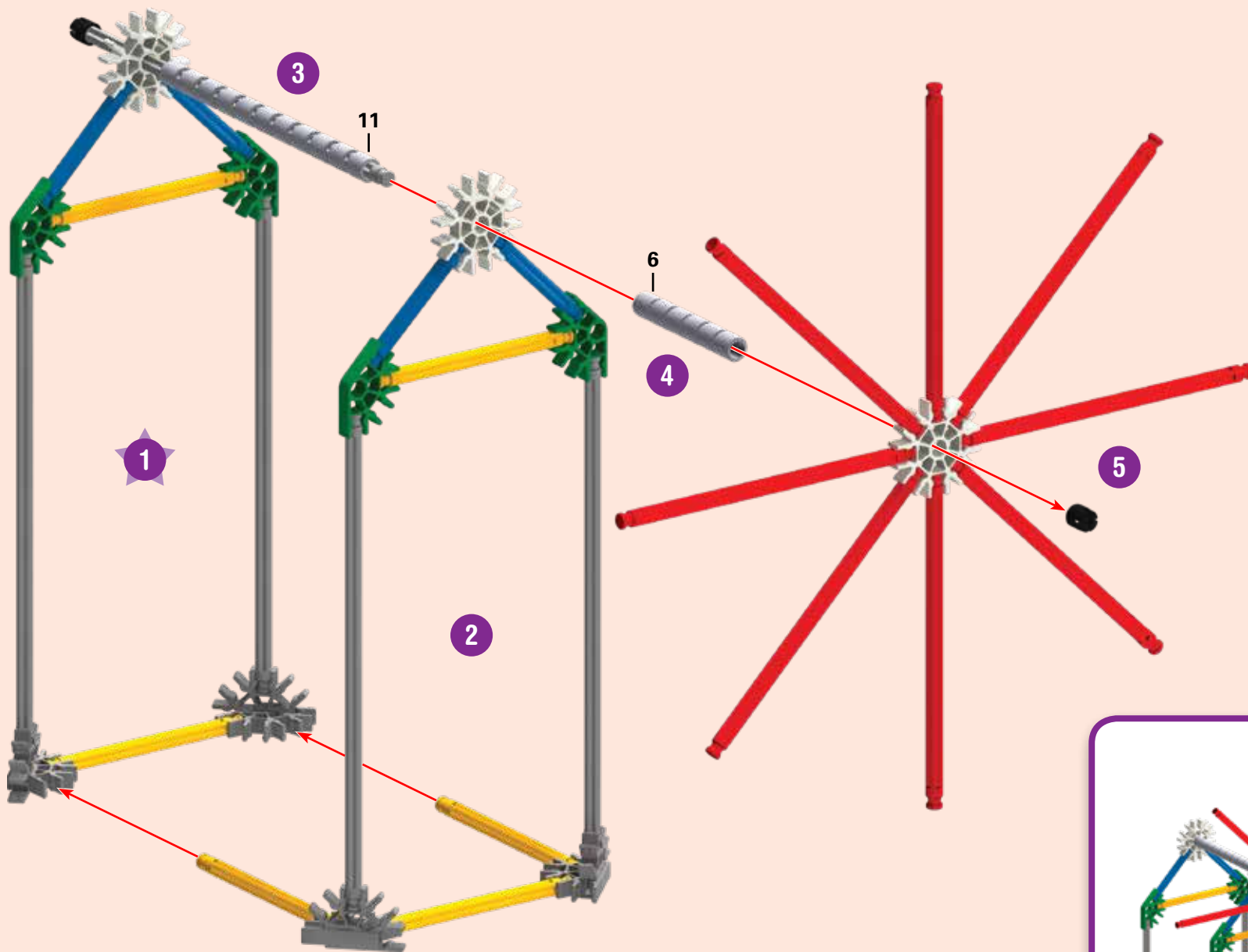

**Windmüll**  
**Moulin à Vent**  
**Windmühle**  
**Windmolen**

**CAUTION:** Use care where you use these models. Models could damage furniture or walls, or injure people or pets.

**ATTENTION :** Utilisez des soins là où vous utilisez ce modèles. Modèles pourrait endommager les meubles ou les murs, ou blesser des personnes ou des animaux domestiques.

**PRECAUCIÓN:** Tenga mucho cuidado cuando se utiliza este modelos. Modelos podría dañar los muebles o las paredes, o lesionar a personas o animales.

**VORSICHT:** Seien Sie vorsichtig, wo Sie diese Modelle zu verwenden.

Die Modelle könnten Möbel und Wände beschädigen oder Personen und Haustiere verletzen.

**AVVERTENZA:** Fare attenzione dove usi questi Modeli. Questi modeli potrebbero fare danno a pareti, o far male a persone o animali.

**CUIDADO:** Tenha cuidado onde você usa esses modelos. Modelos podem danificar móveis ou paredes, ou ferir pessoas ou animais de estimação.

**VOORZICHTIG:** Wees voorzichtig waar u deze modellen te gebruiken. Modellen kunnen meubels of muren beschadigen of verwonden mensen of dieren.





**Butterfly  
Papillon**

**Schmetterling  
Vlinder**

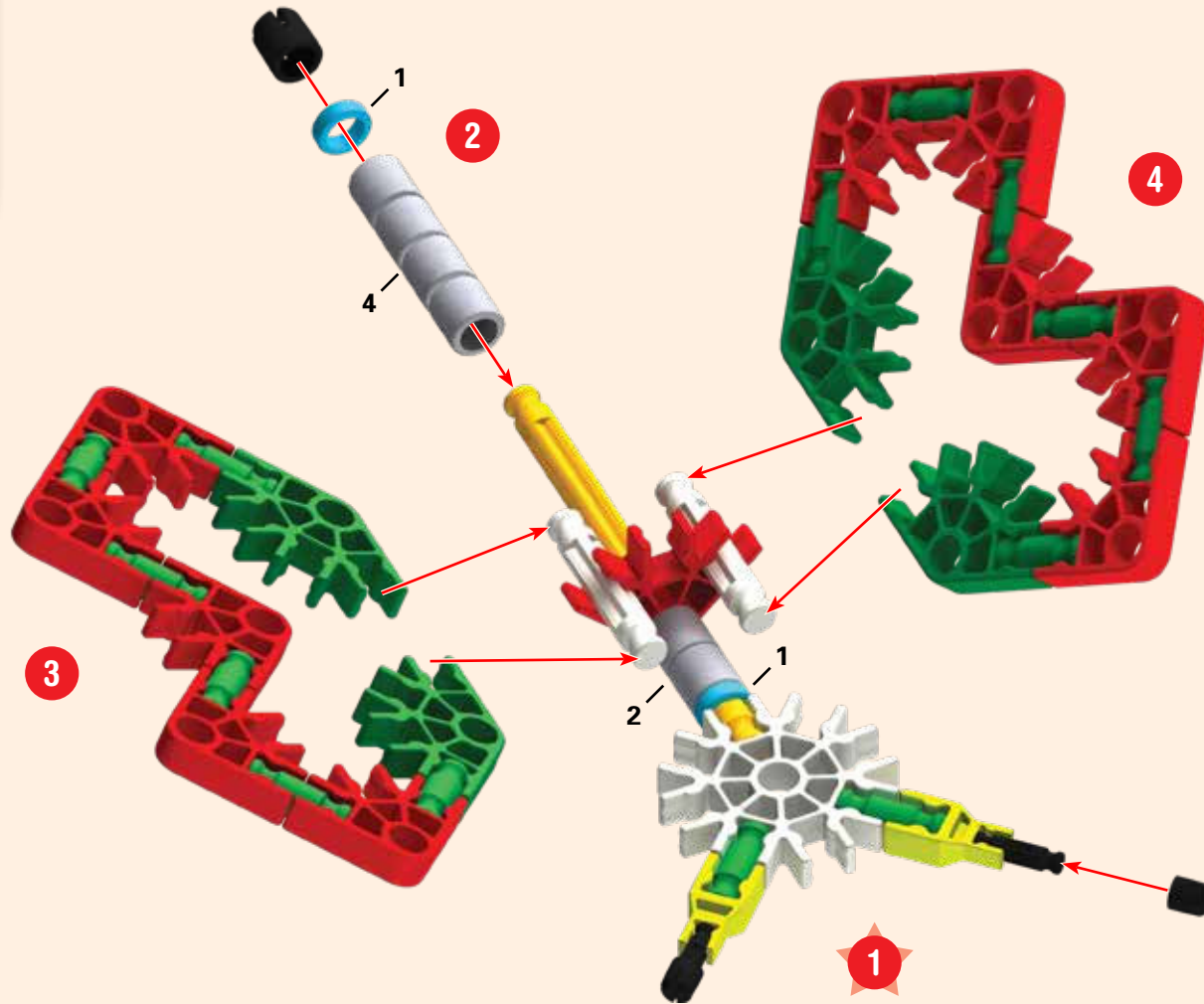

Golf Cart  
Chariot de Golf

Gölfmóbil  
Gölfkar

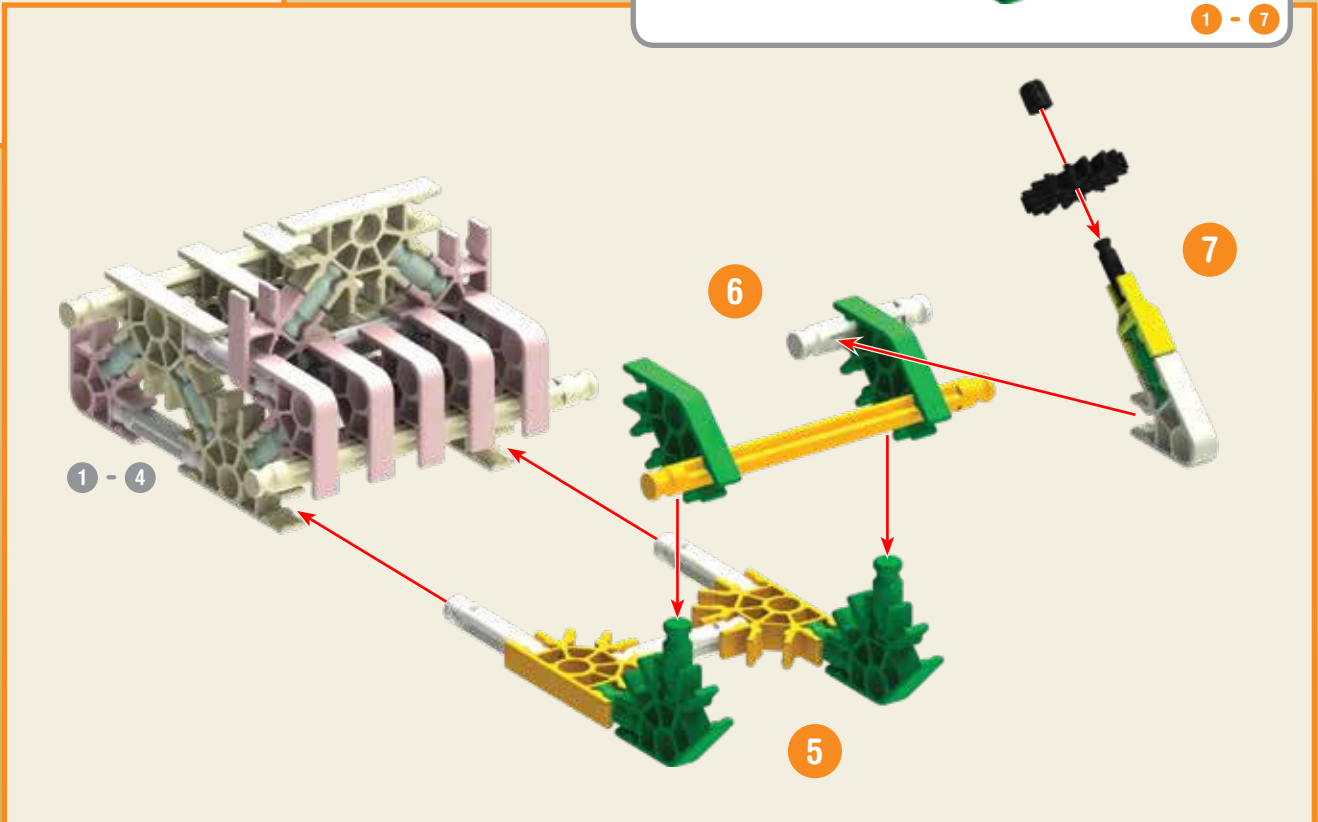
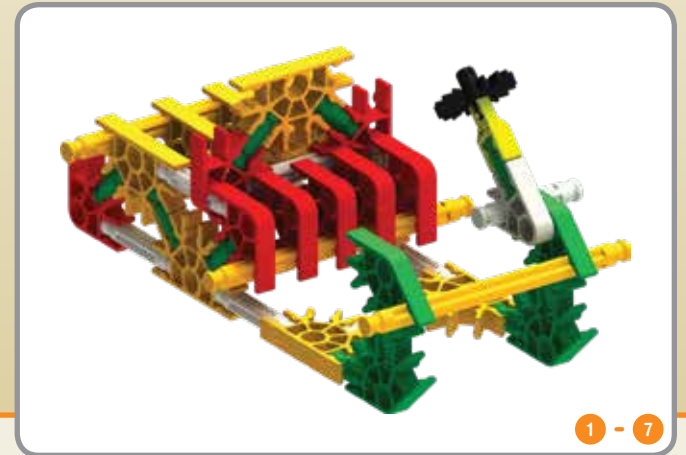
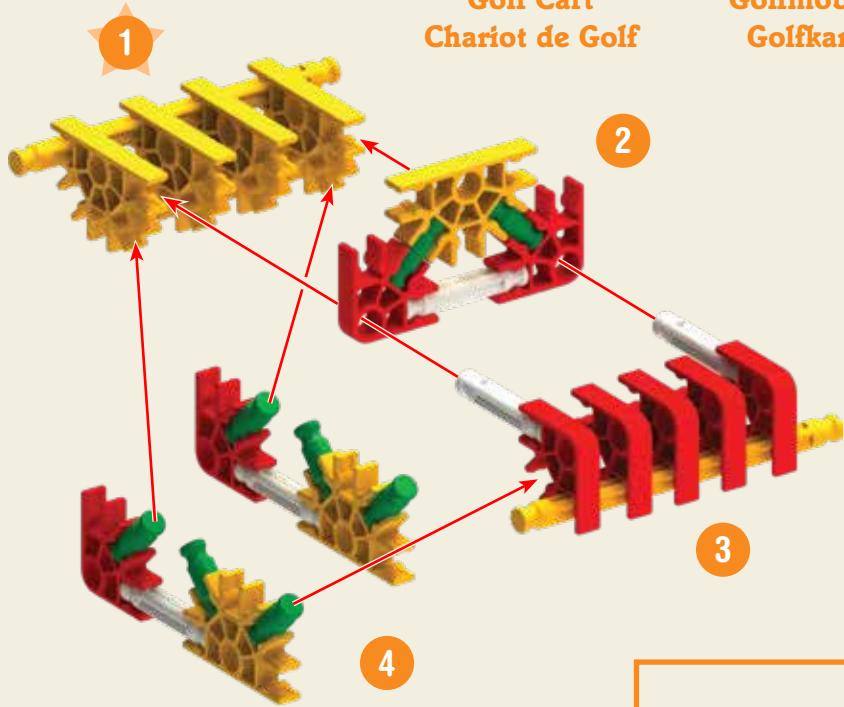

Golf Cart  
Chariot de Golf

Gölfmobil  
Gölfkar

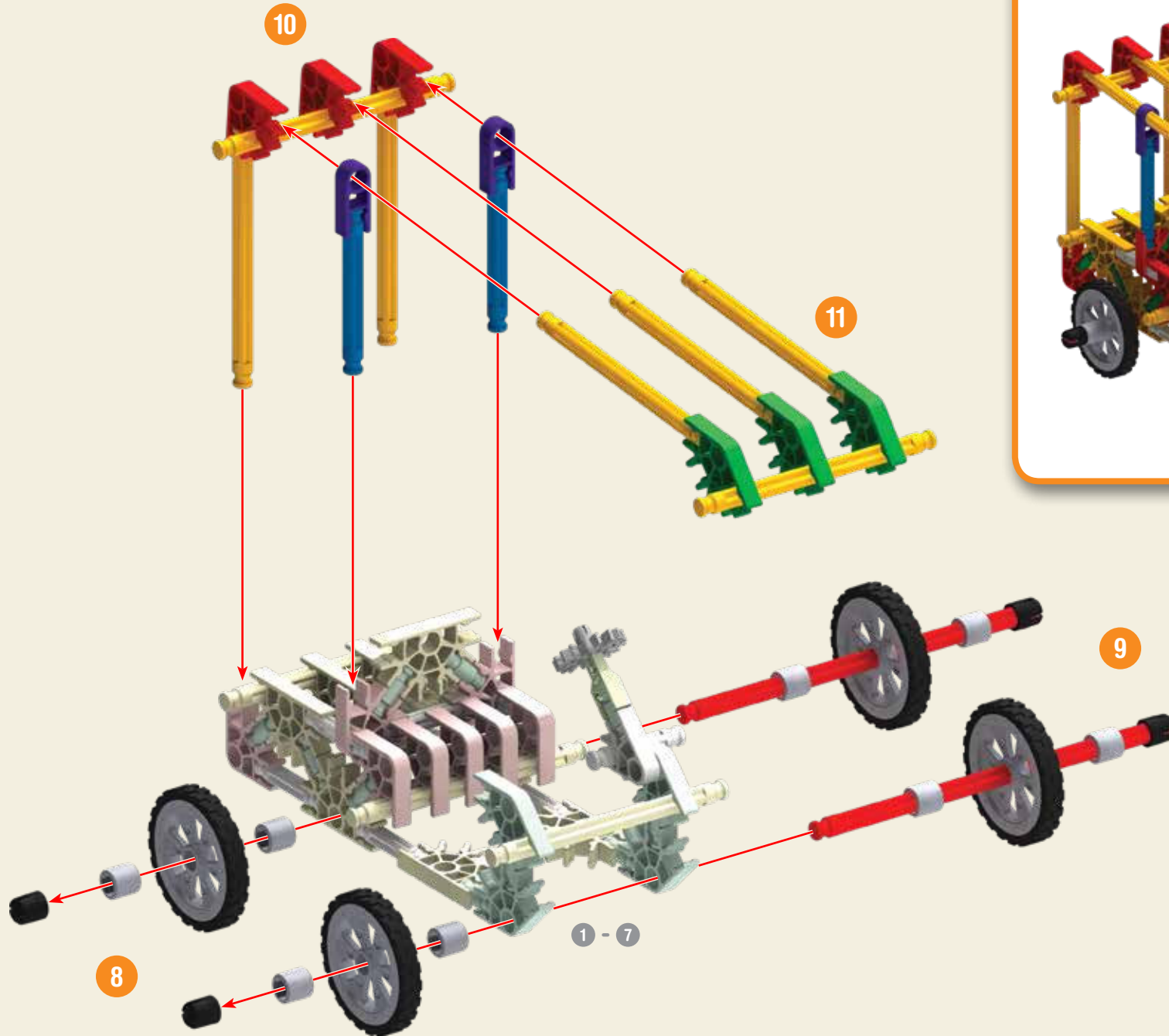

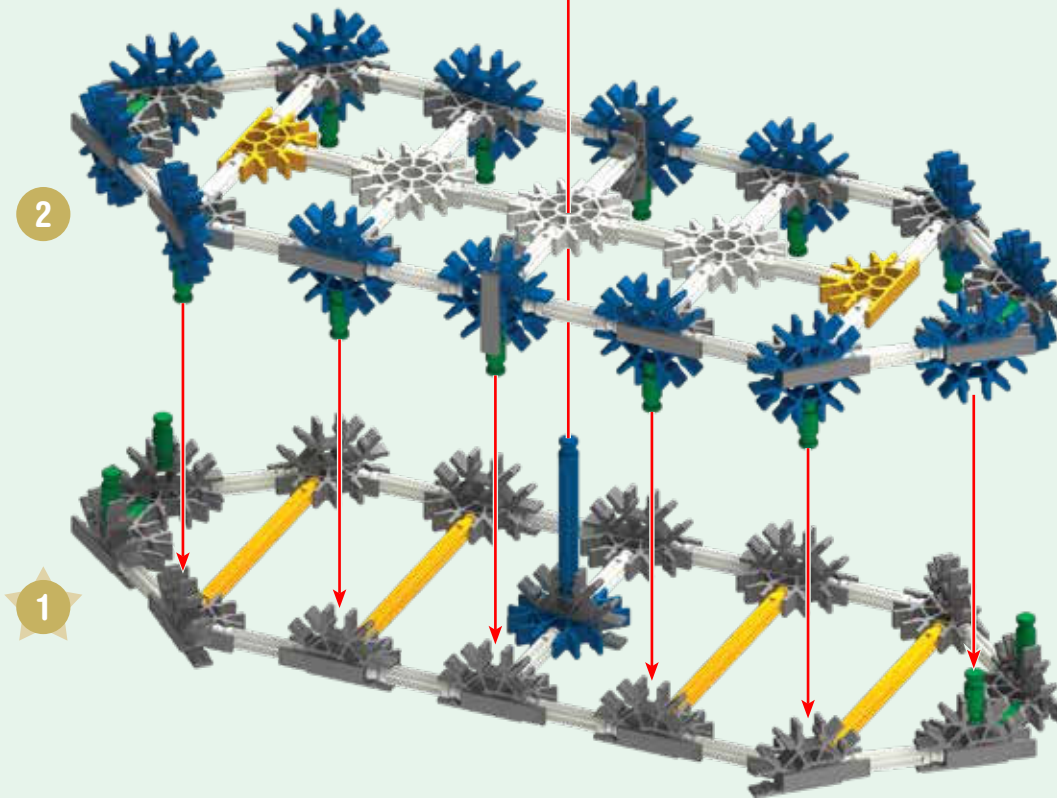
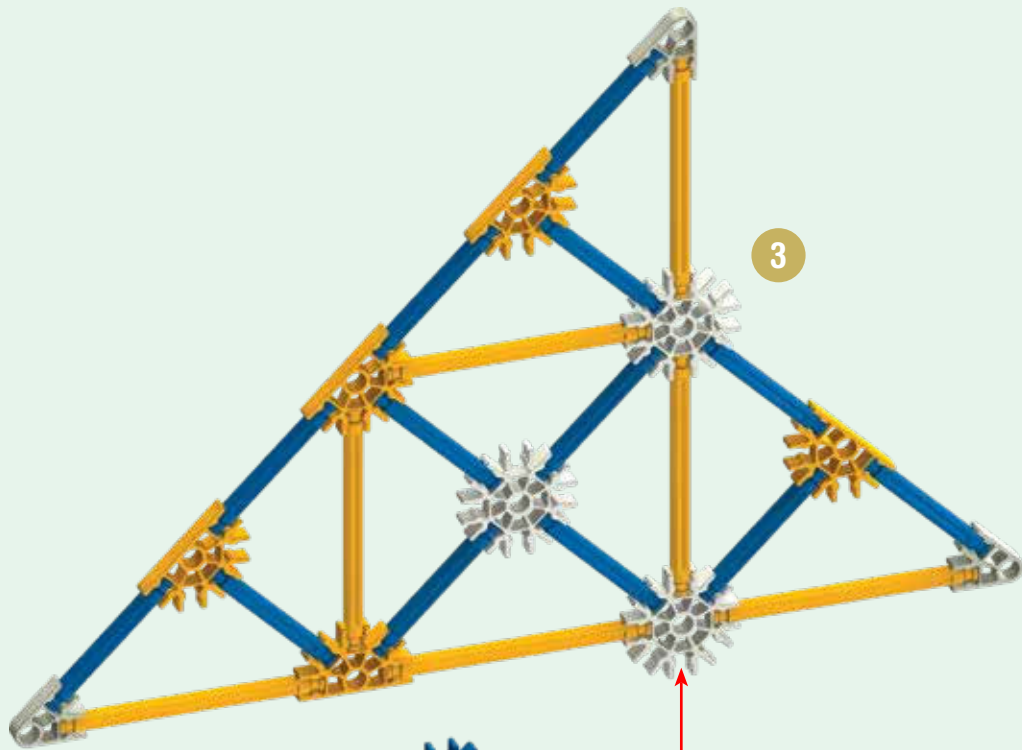

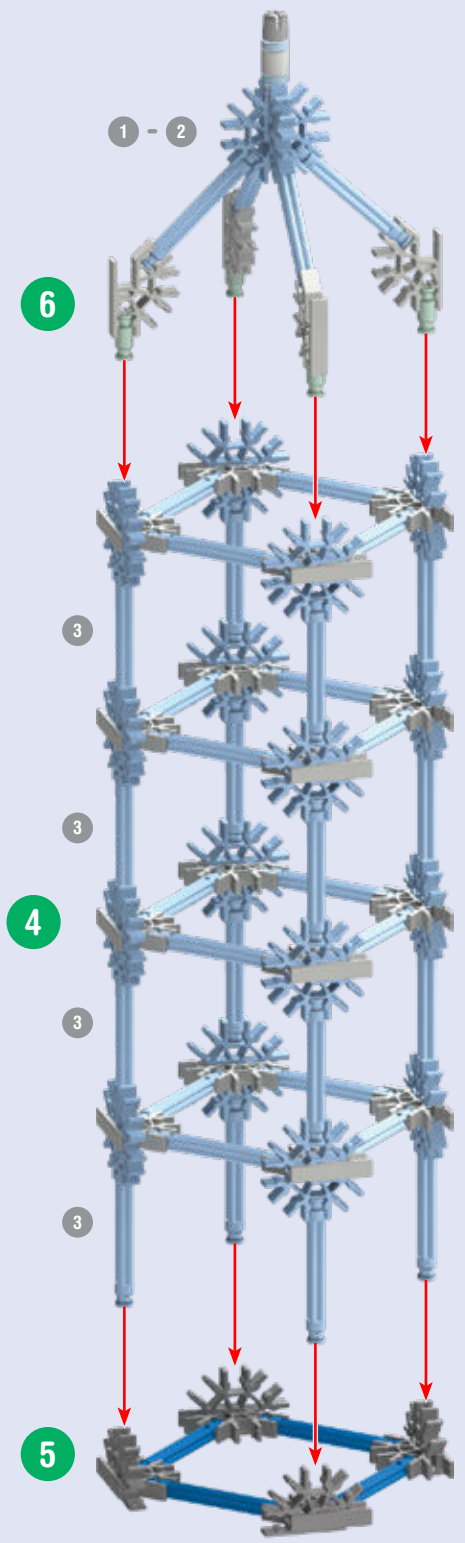
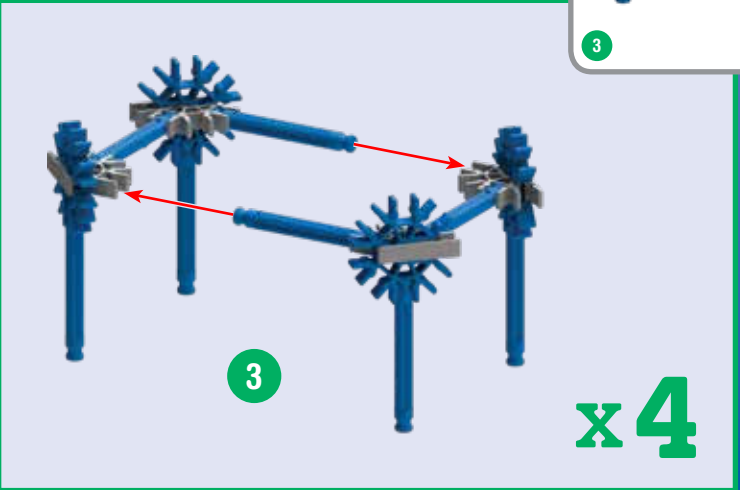
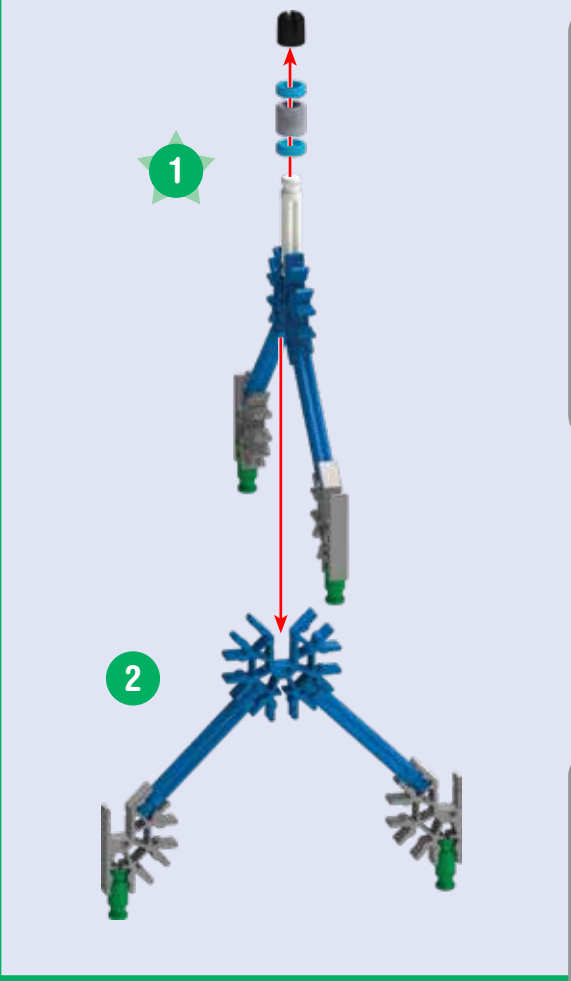

Skyscraper  
Gratte-ciel  
Wolkenkratzer  
Wolkenkrabber

Dinosaur  
Dinosaure

Dinosaurier  
Dinosaurus

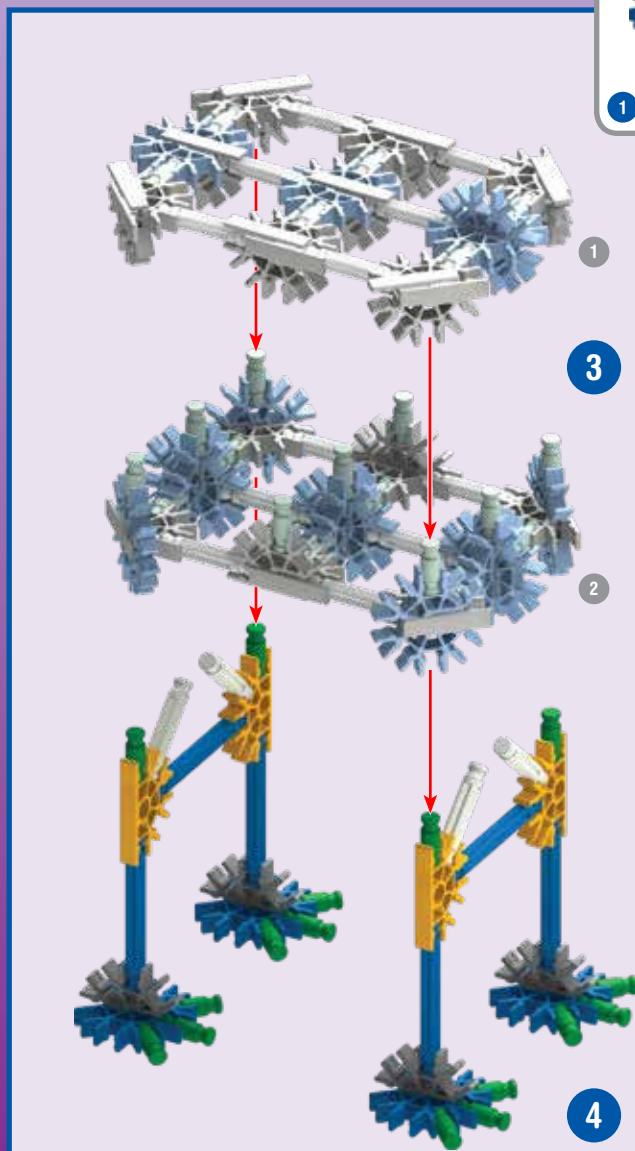
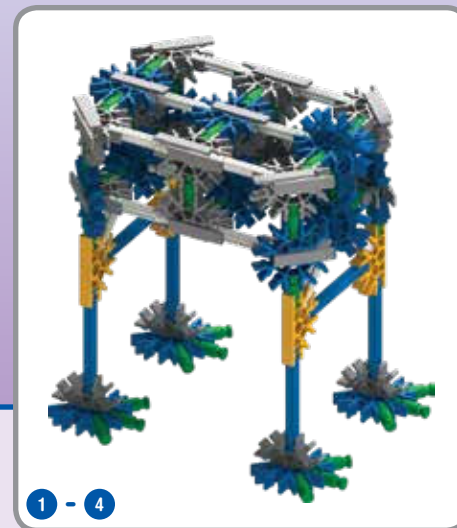
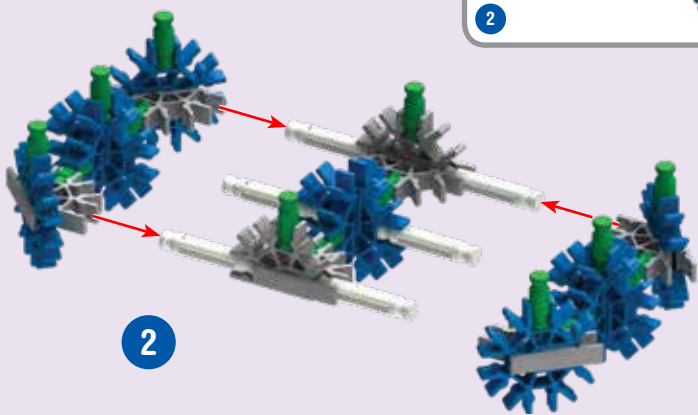
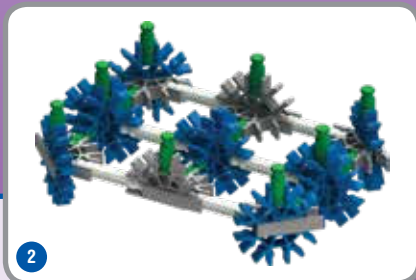
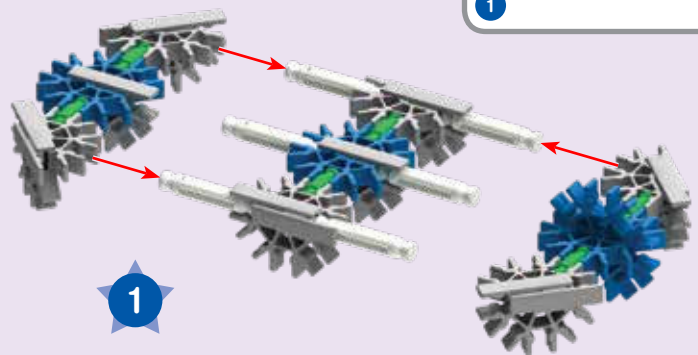
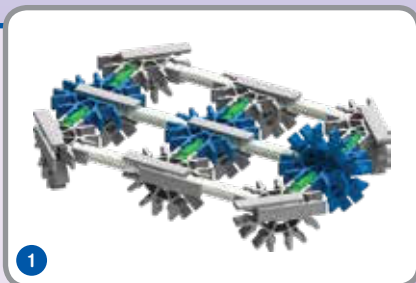

Dinosaur  
Dinosaure

Dinosaurier  
Dinosaurus

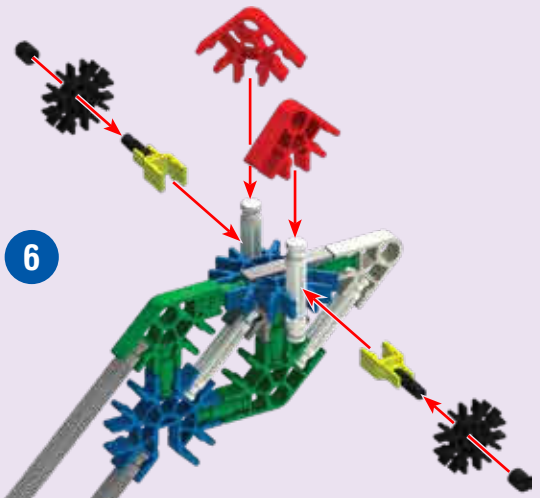
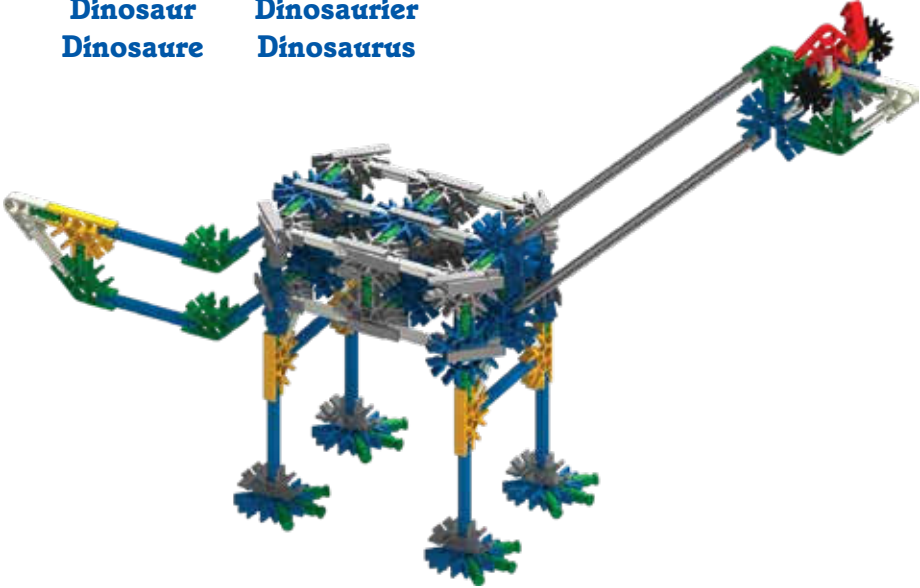

5

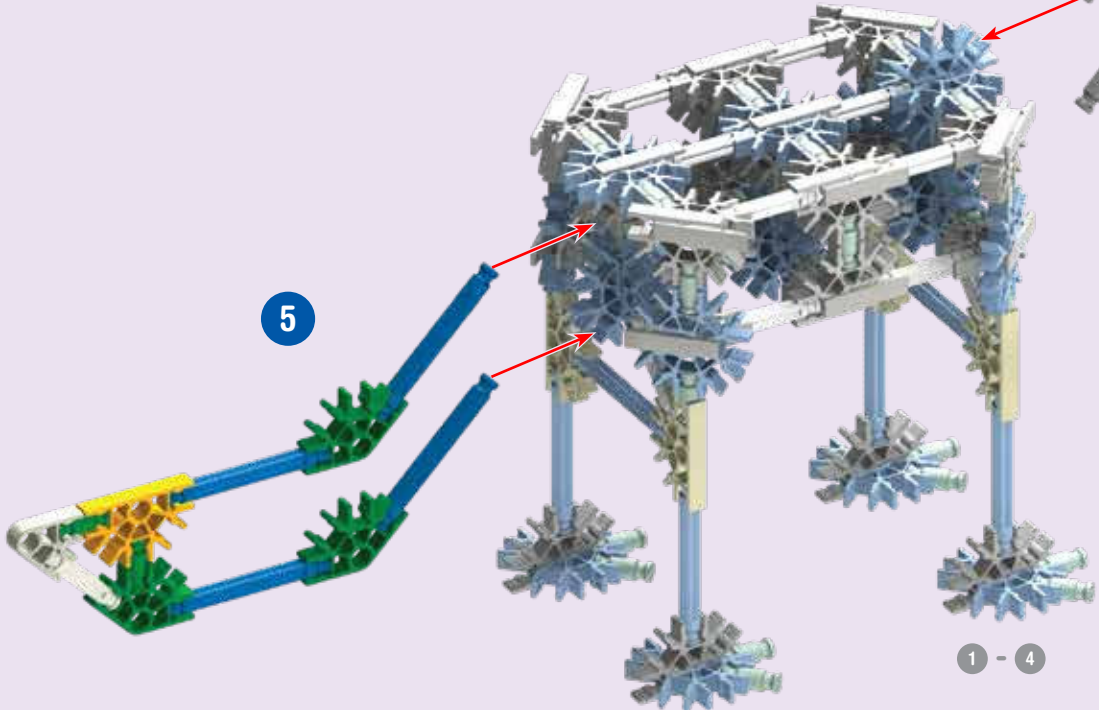

1 - 4

Steamroller  
Rouleau Compresseur

Dampfwalze  
Stoomwals

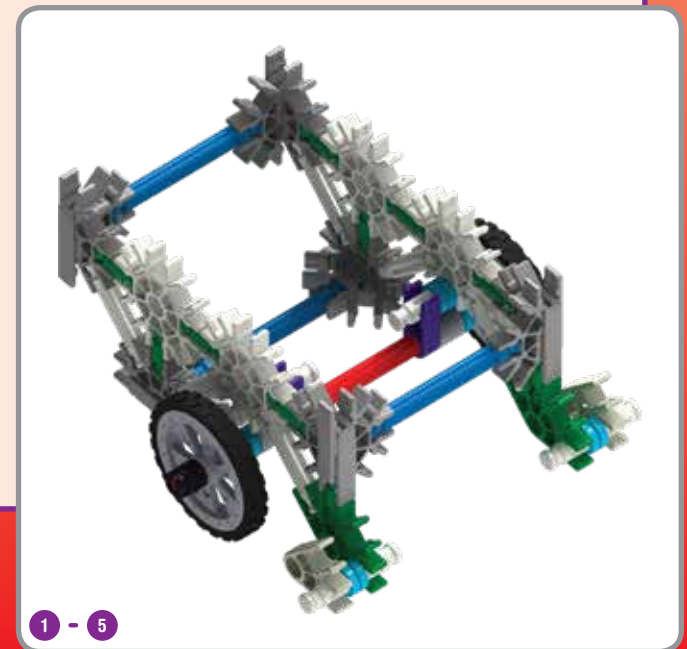
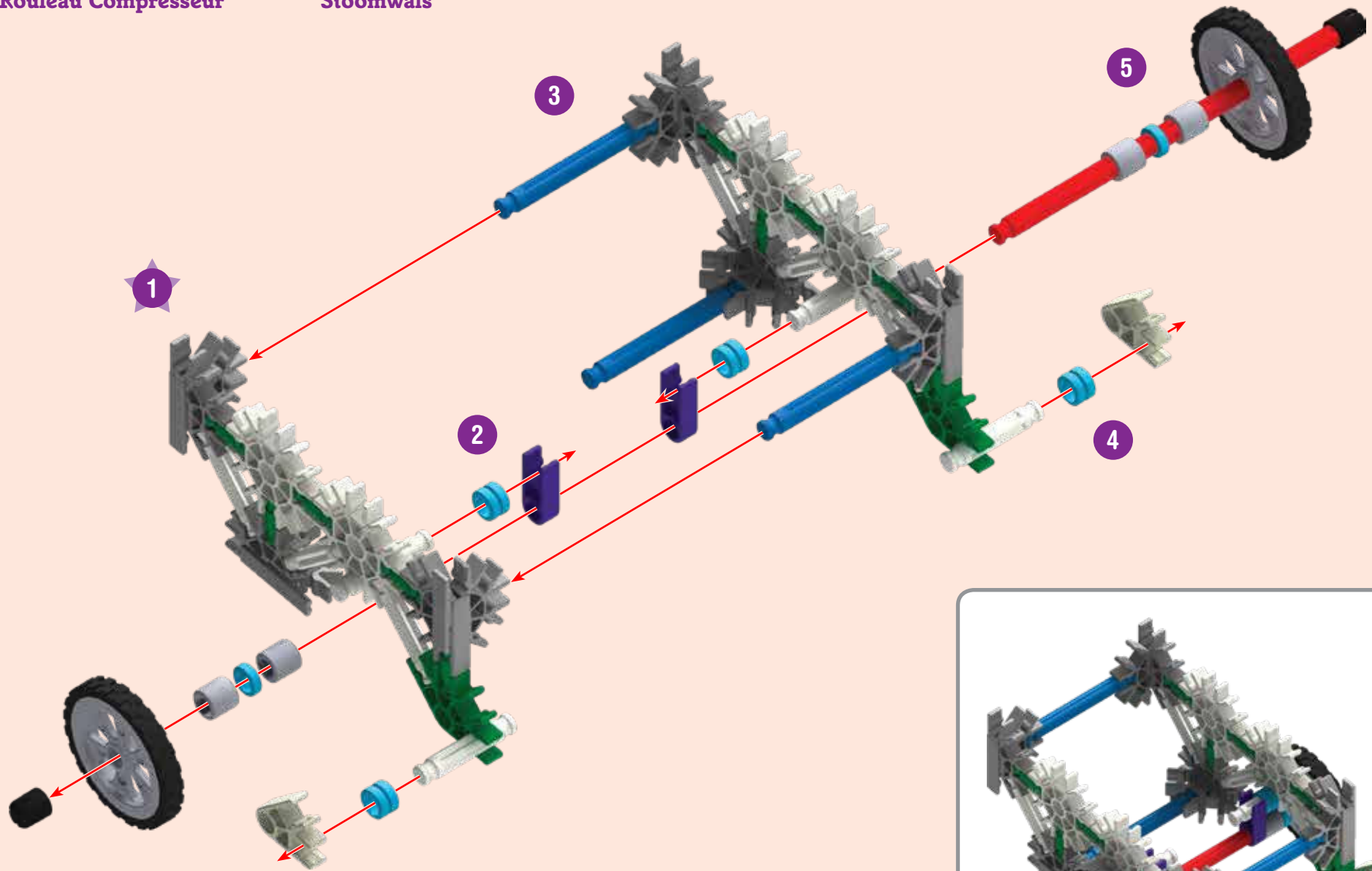



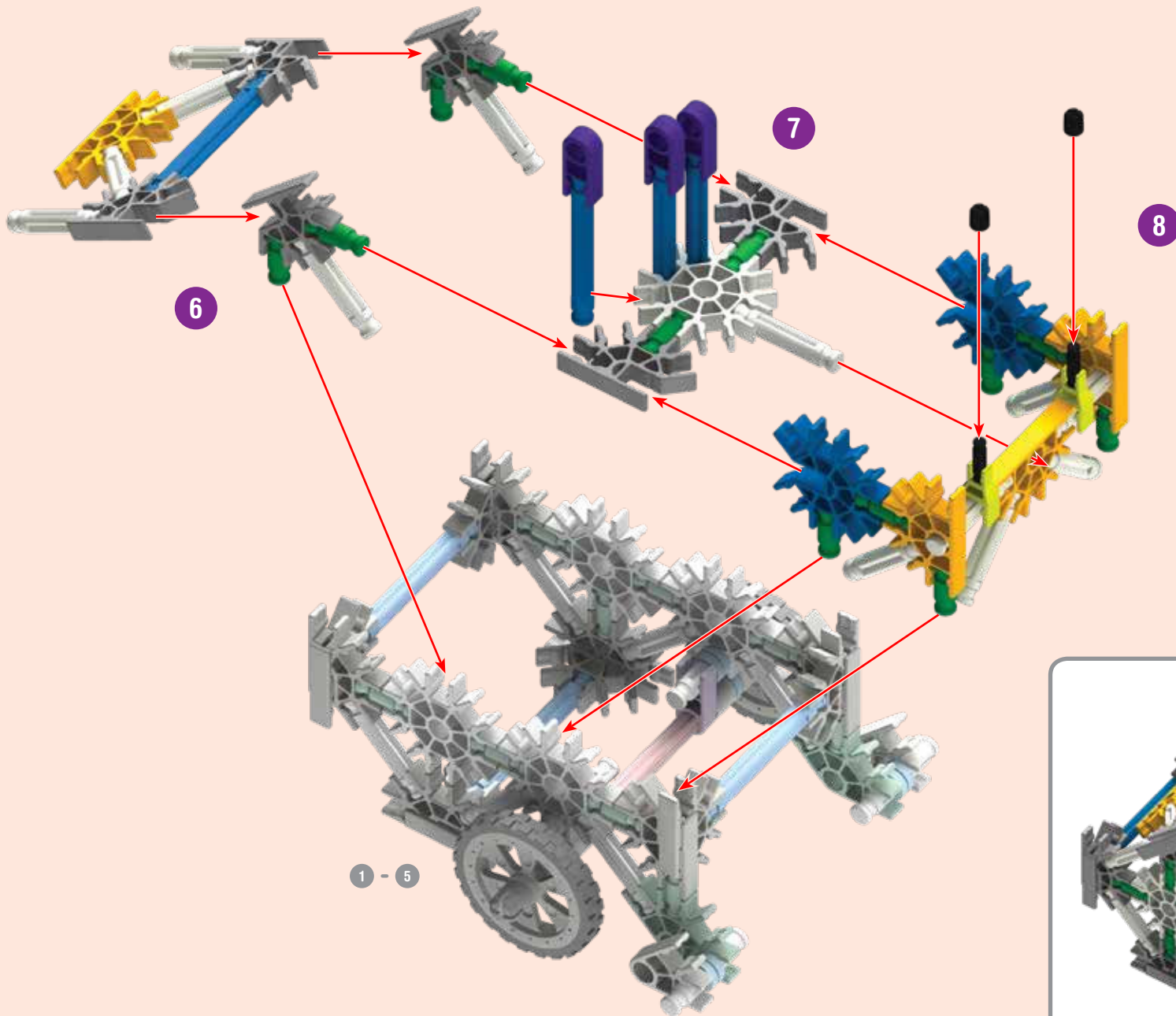

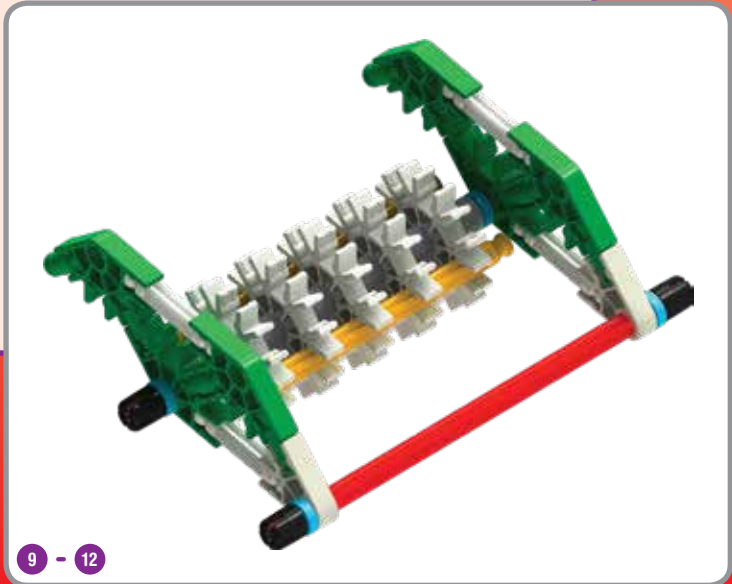
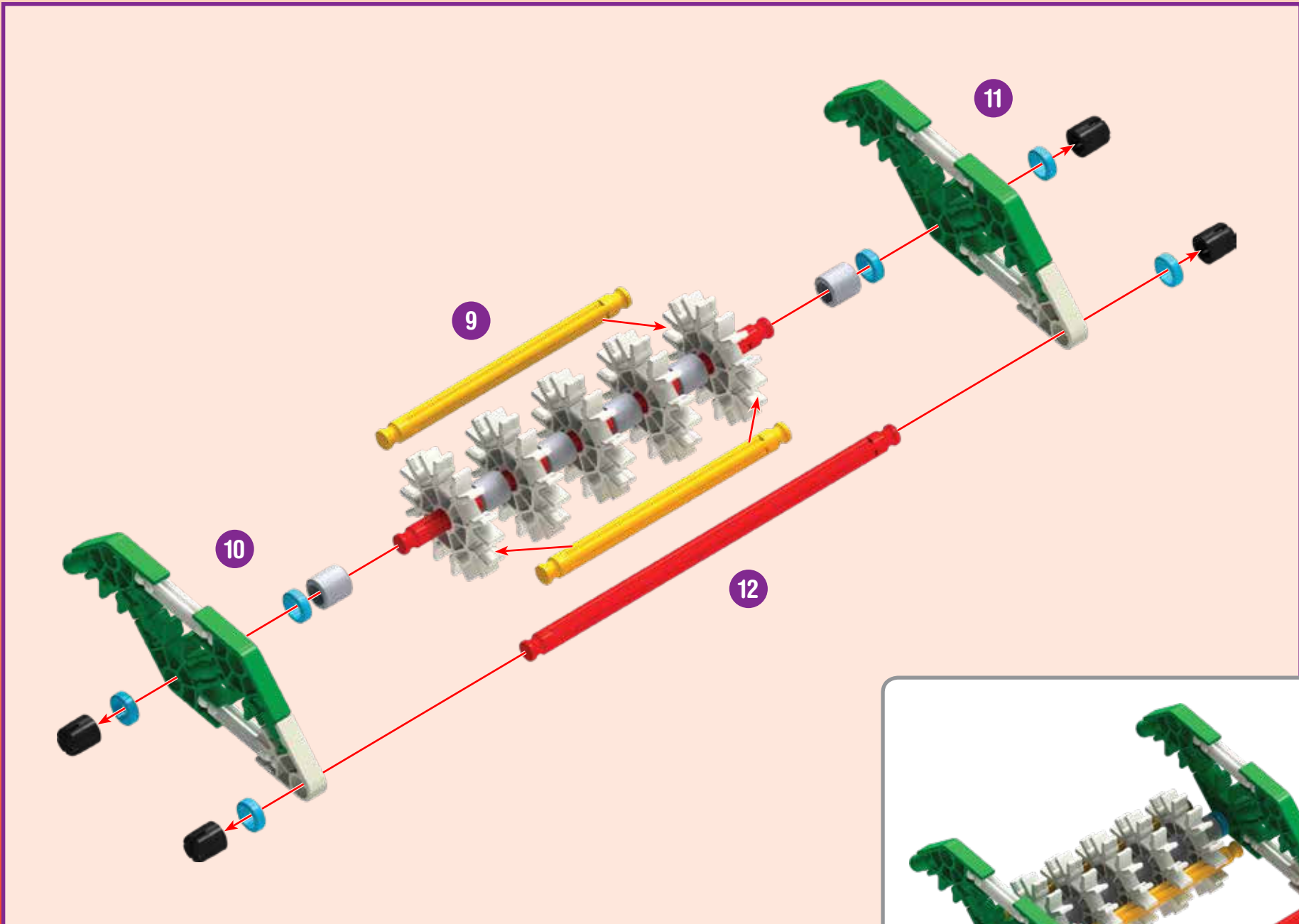

Steamroller  
Rouleau Compresseur  
Dampfwalze  
Stoomwals

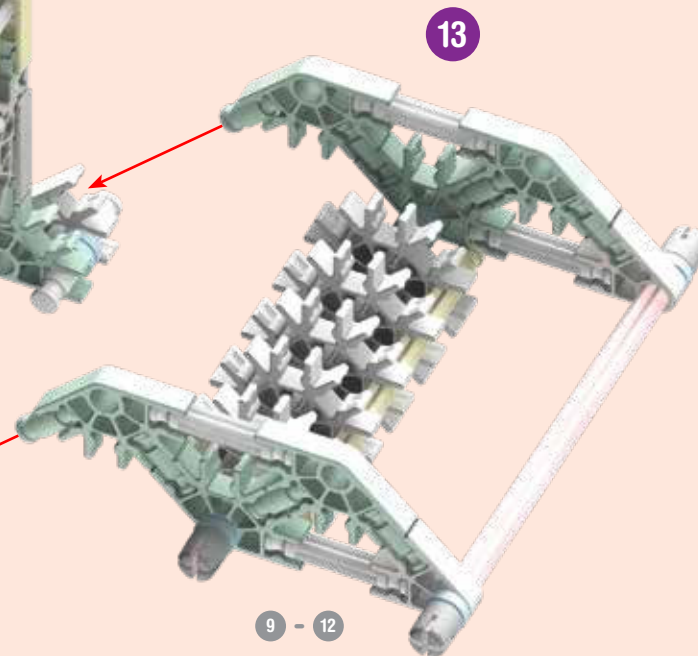
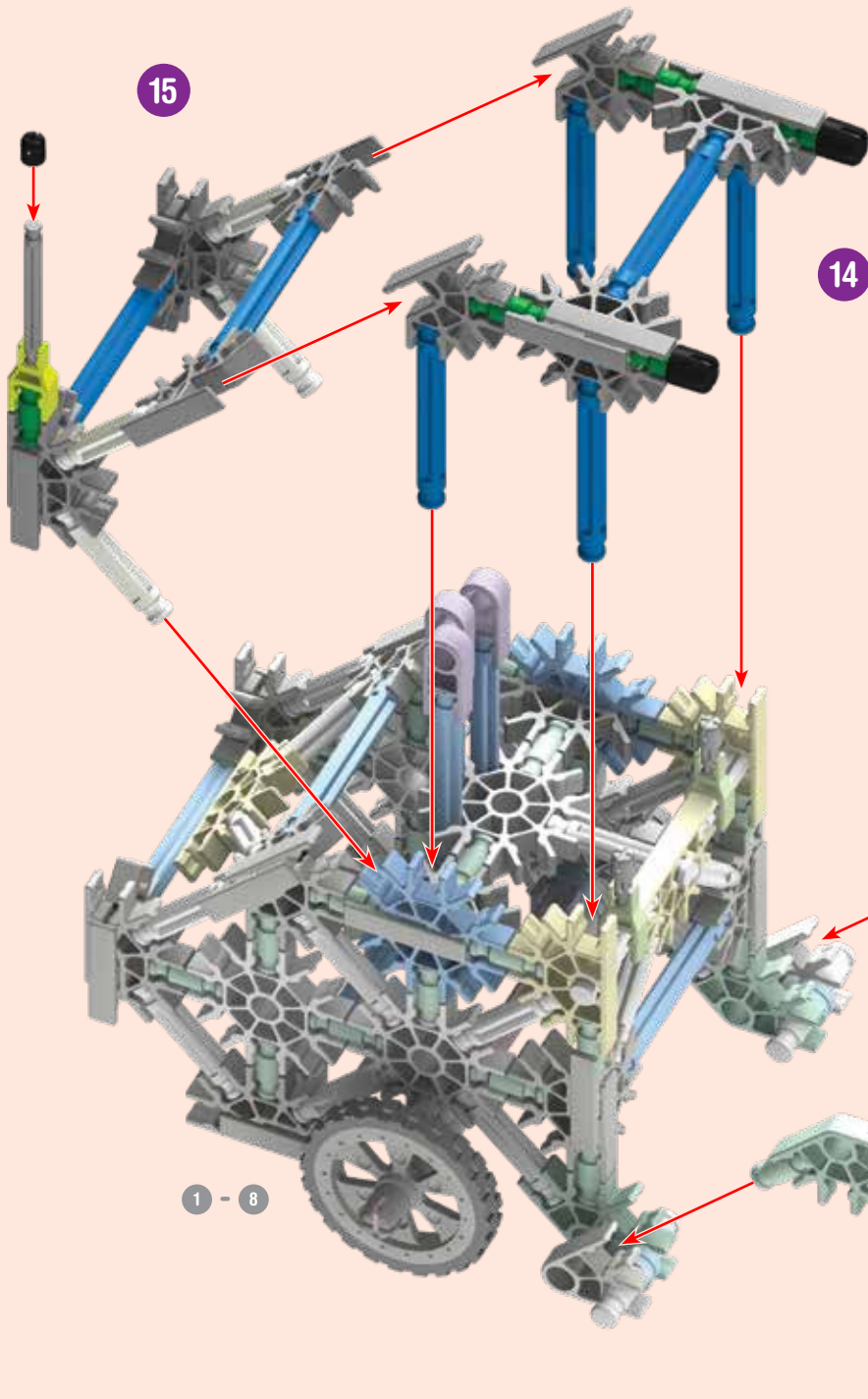

**Bomber  
Bombardier**

**Bomber  
Bommenwerper**

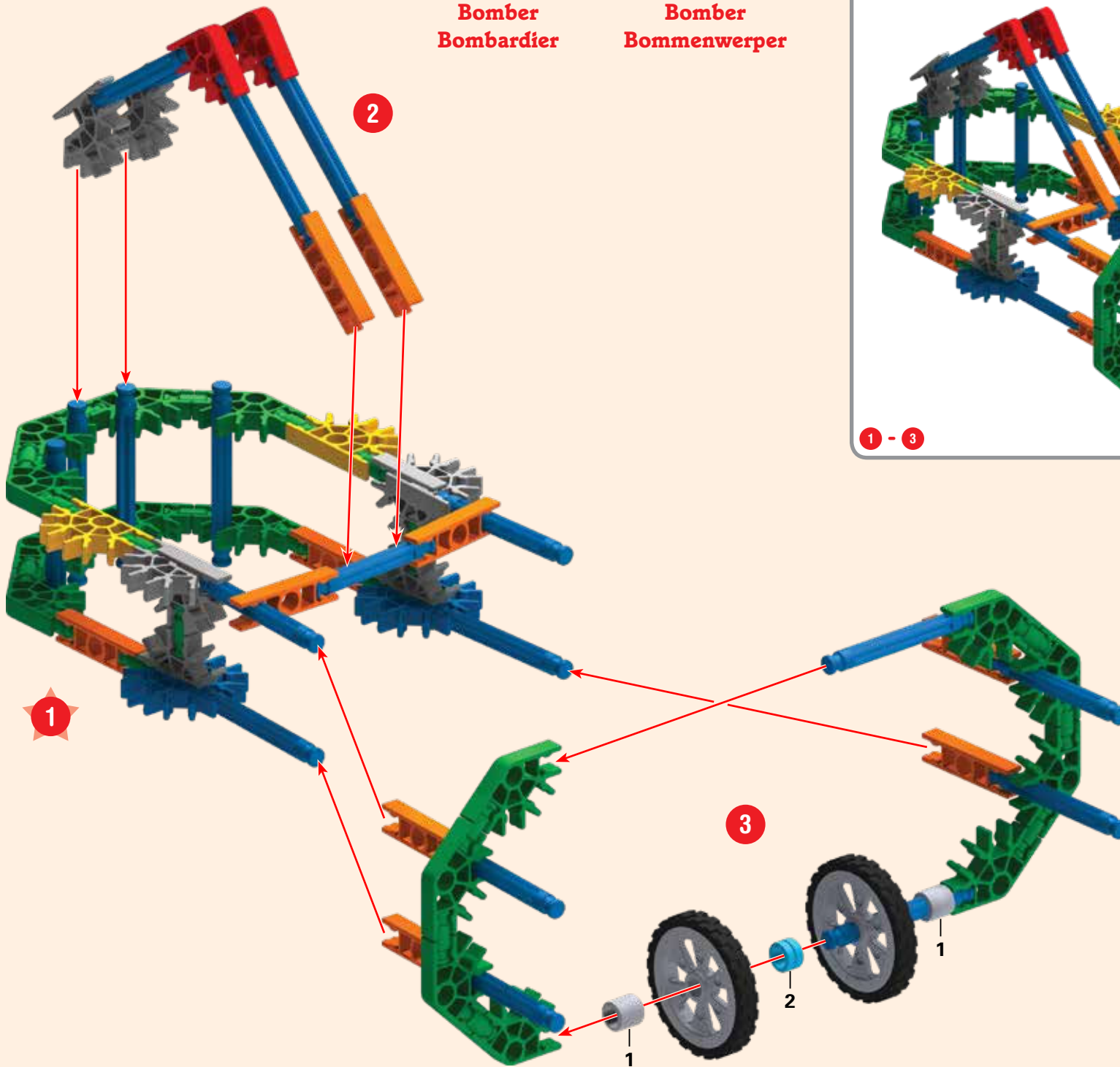

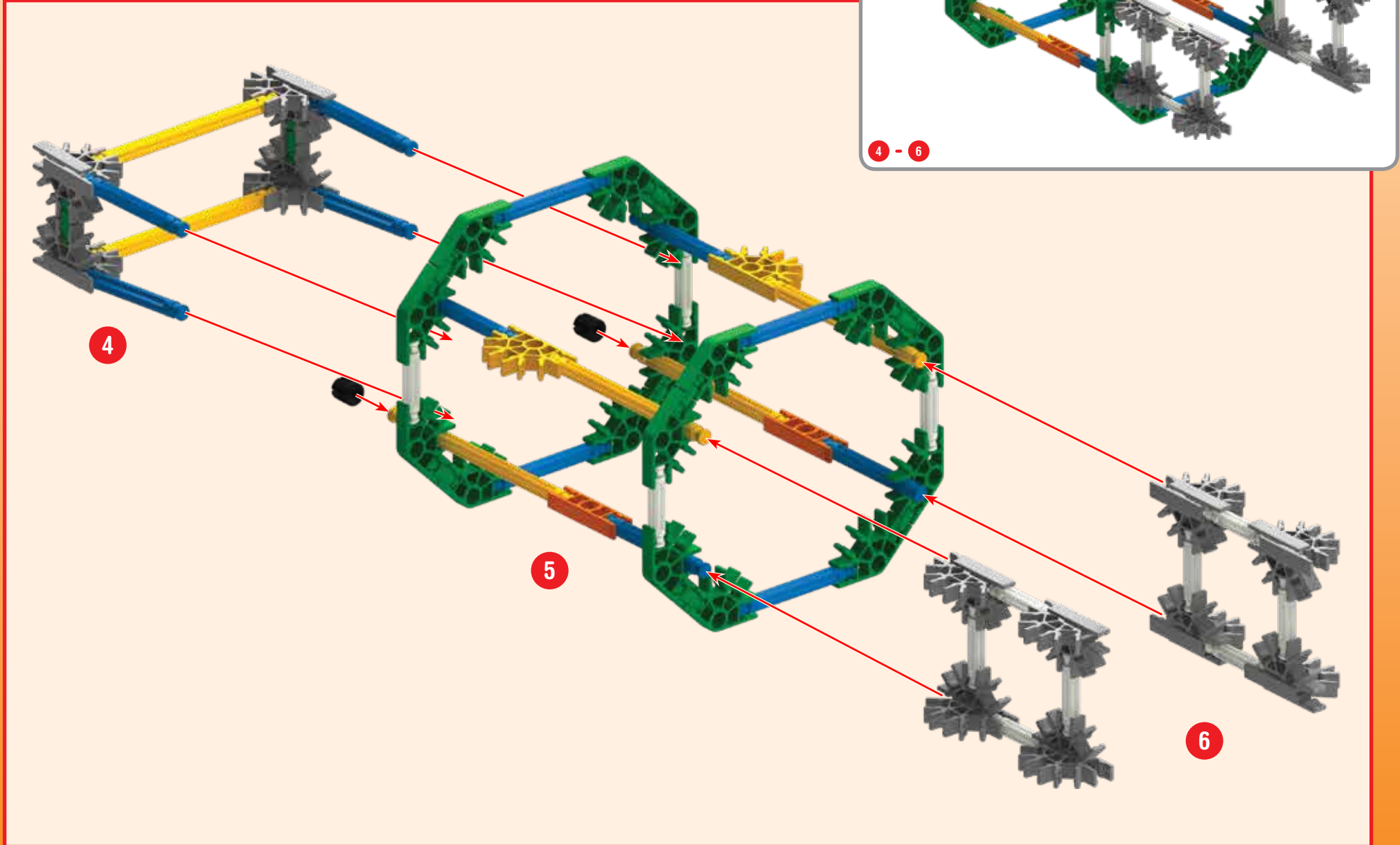

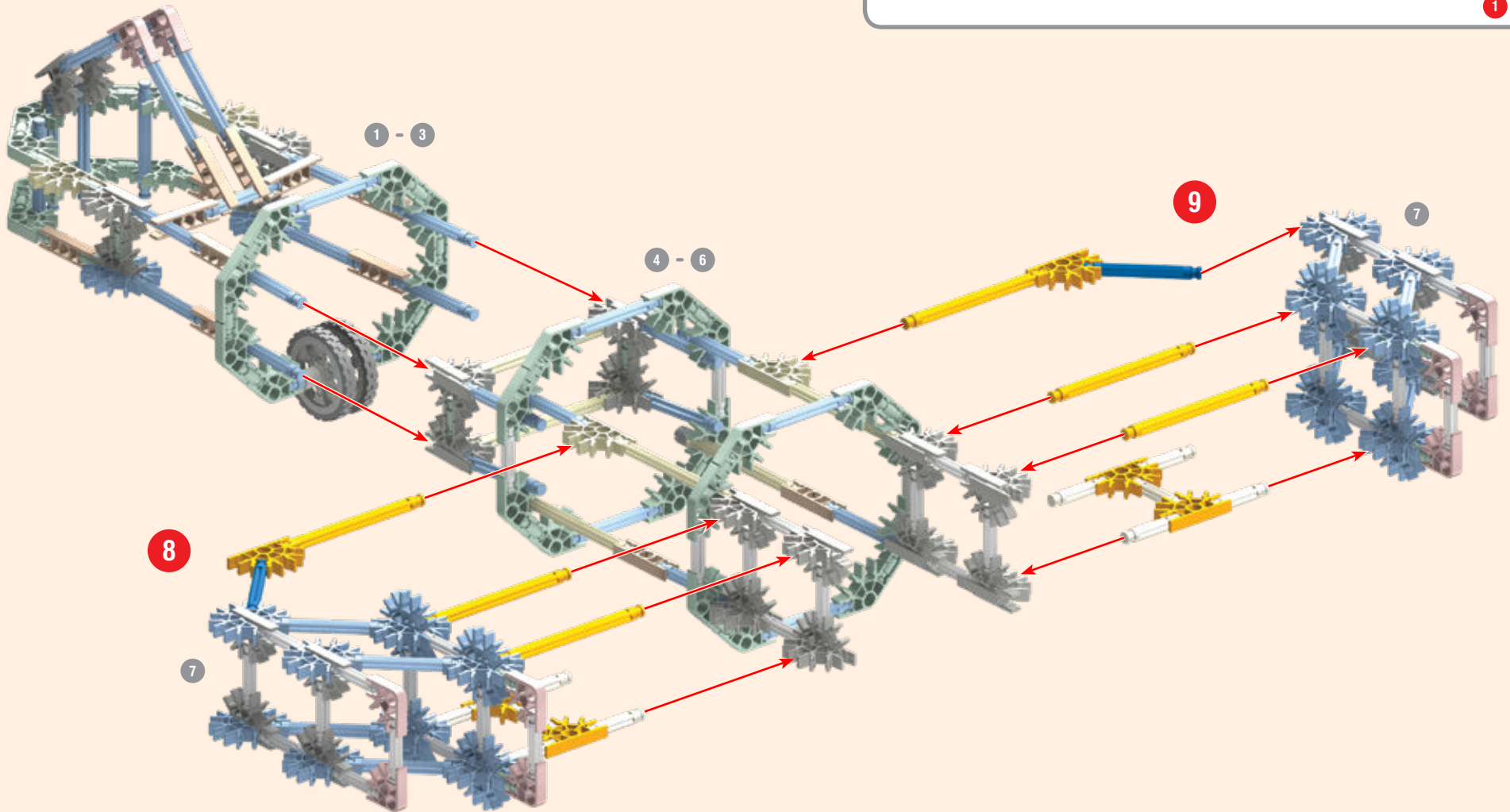
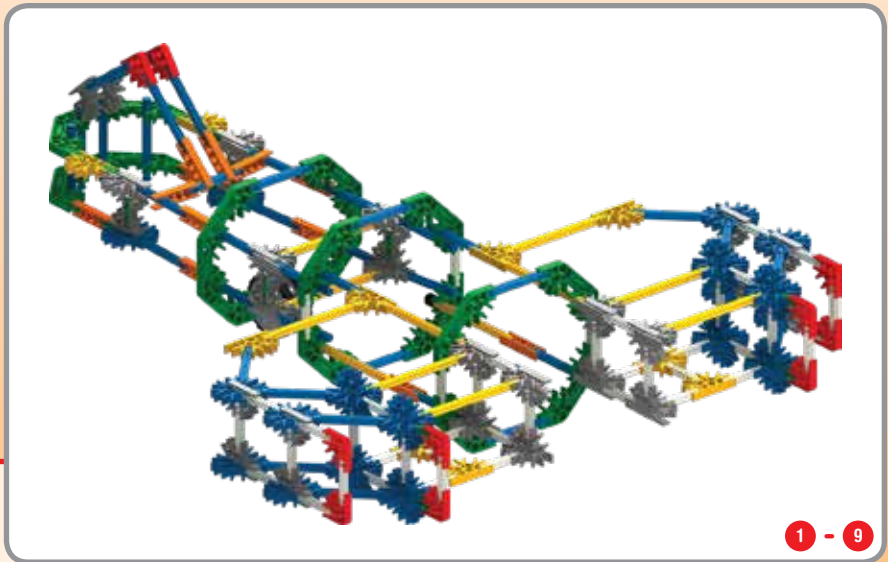
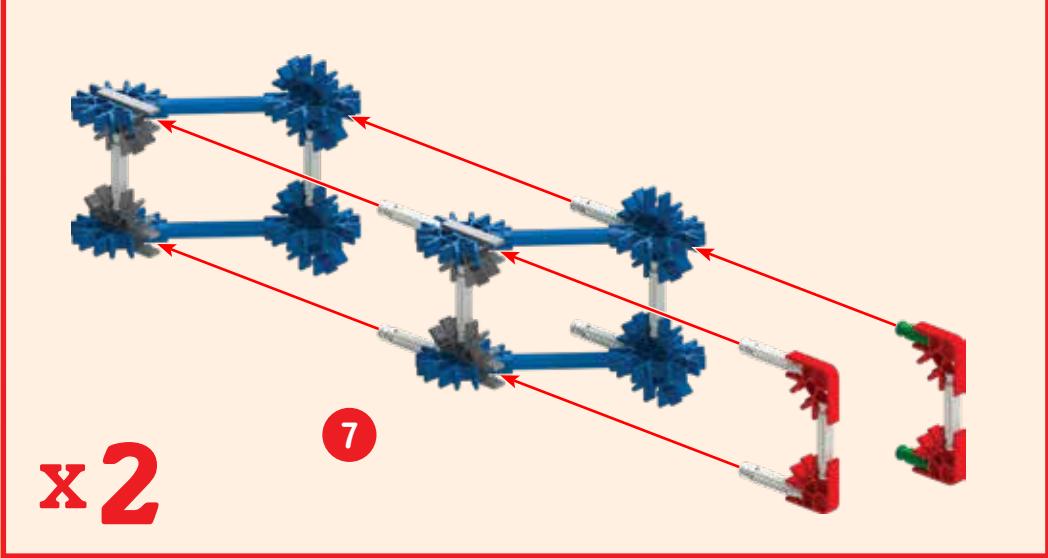

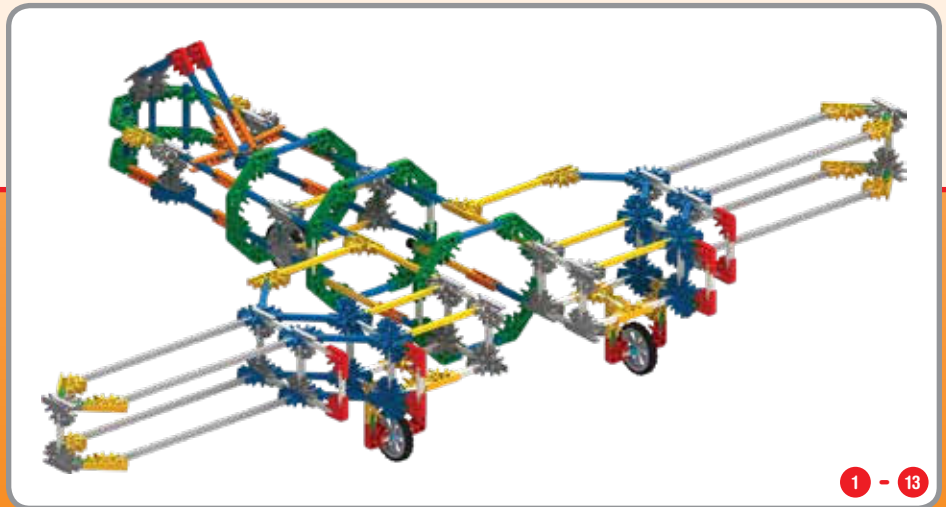
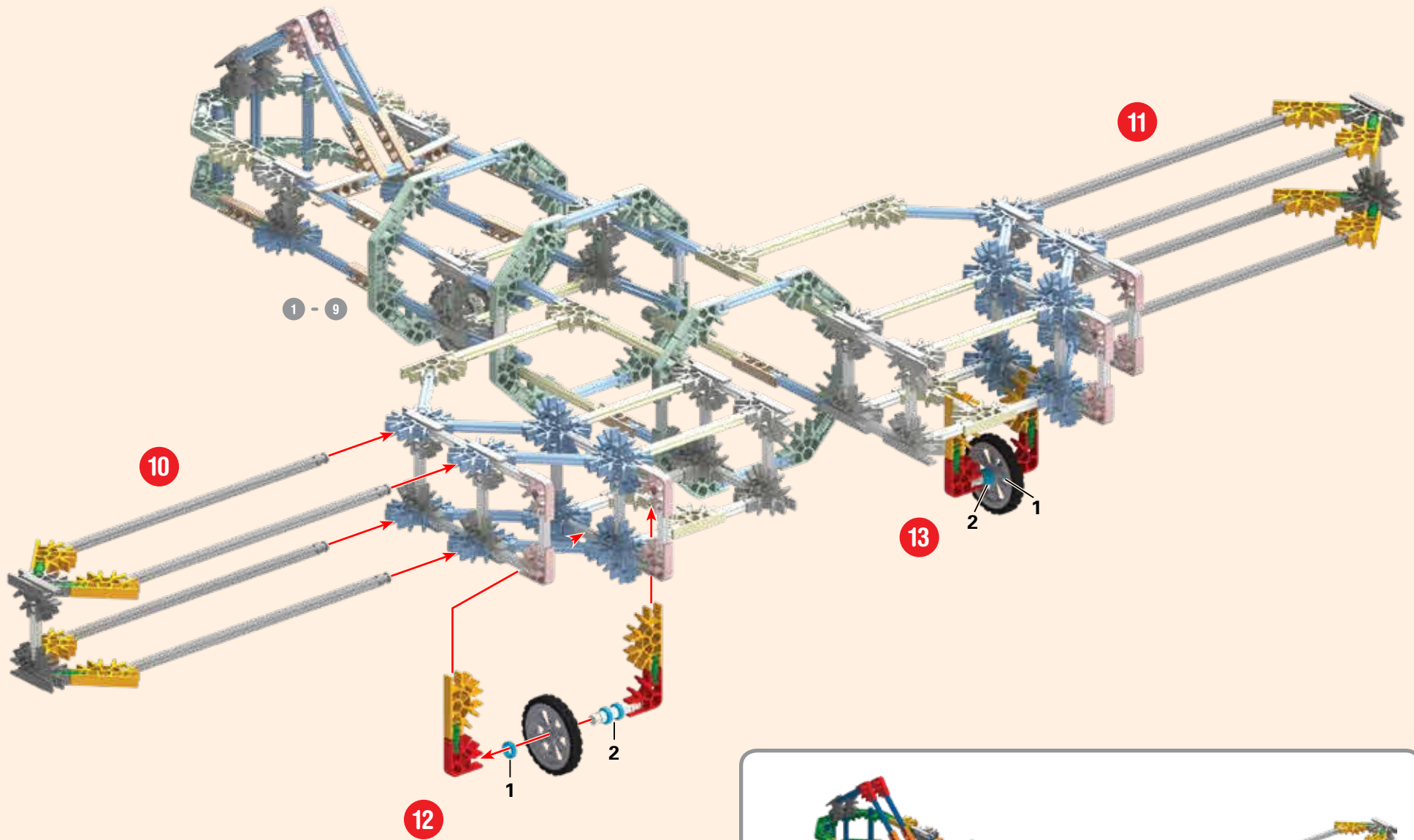

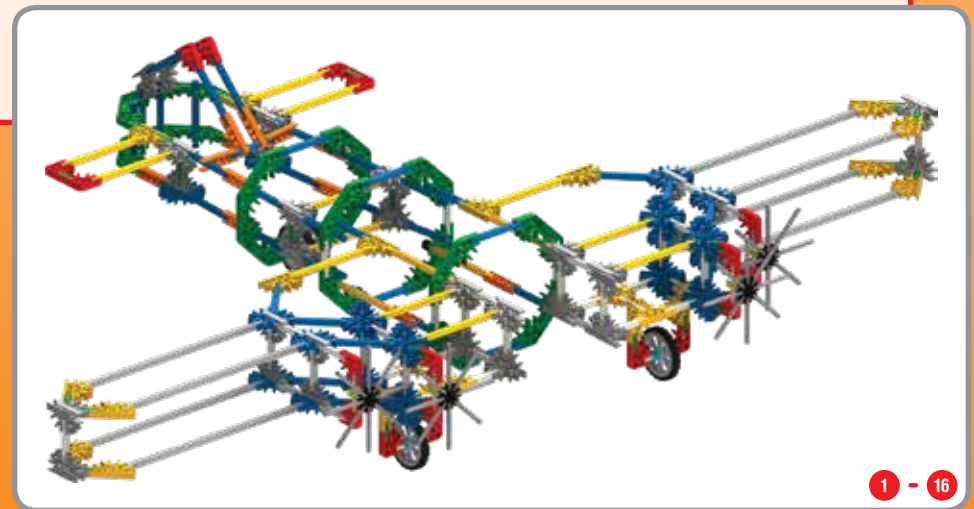
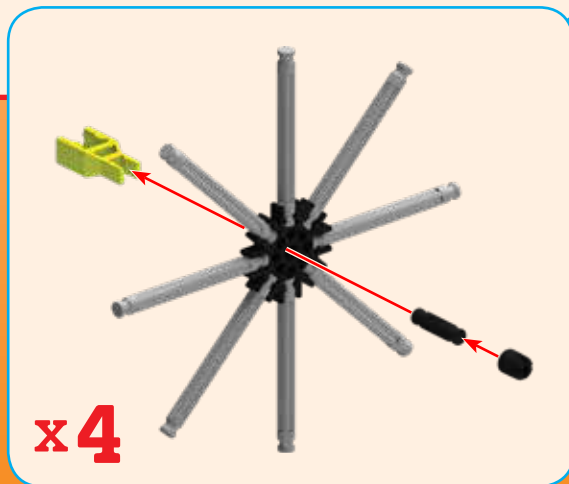
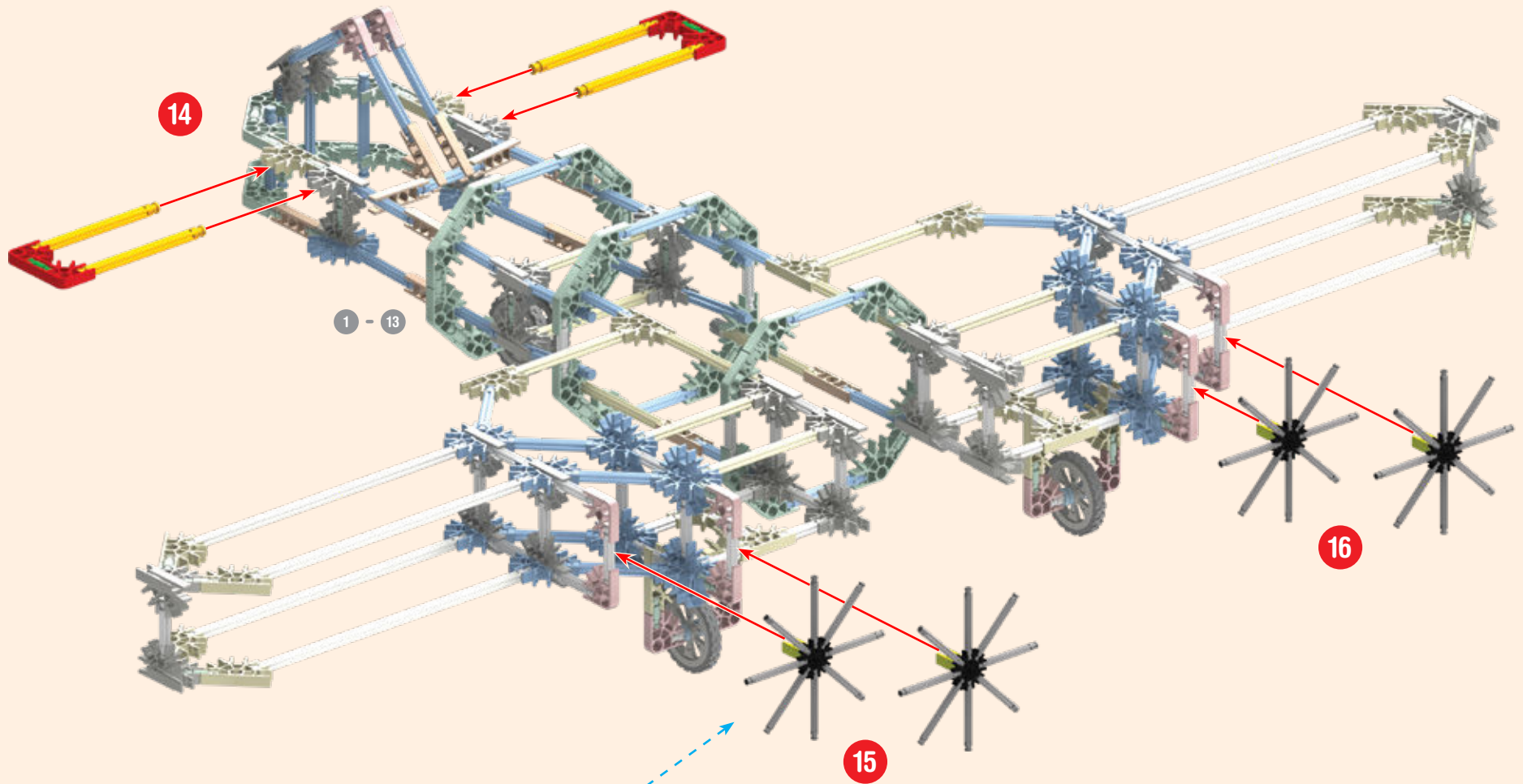



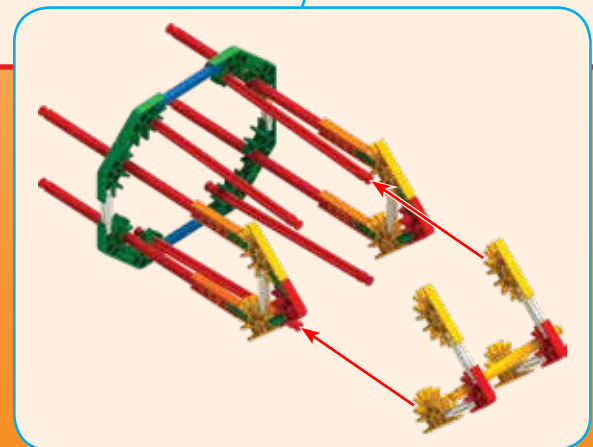
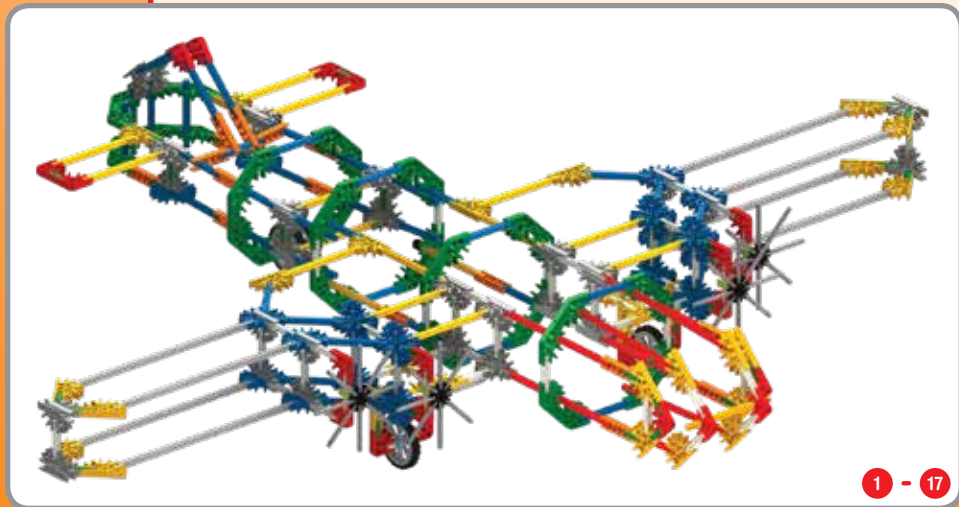
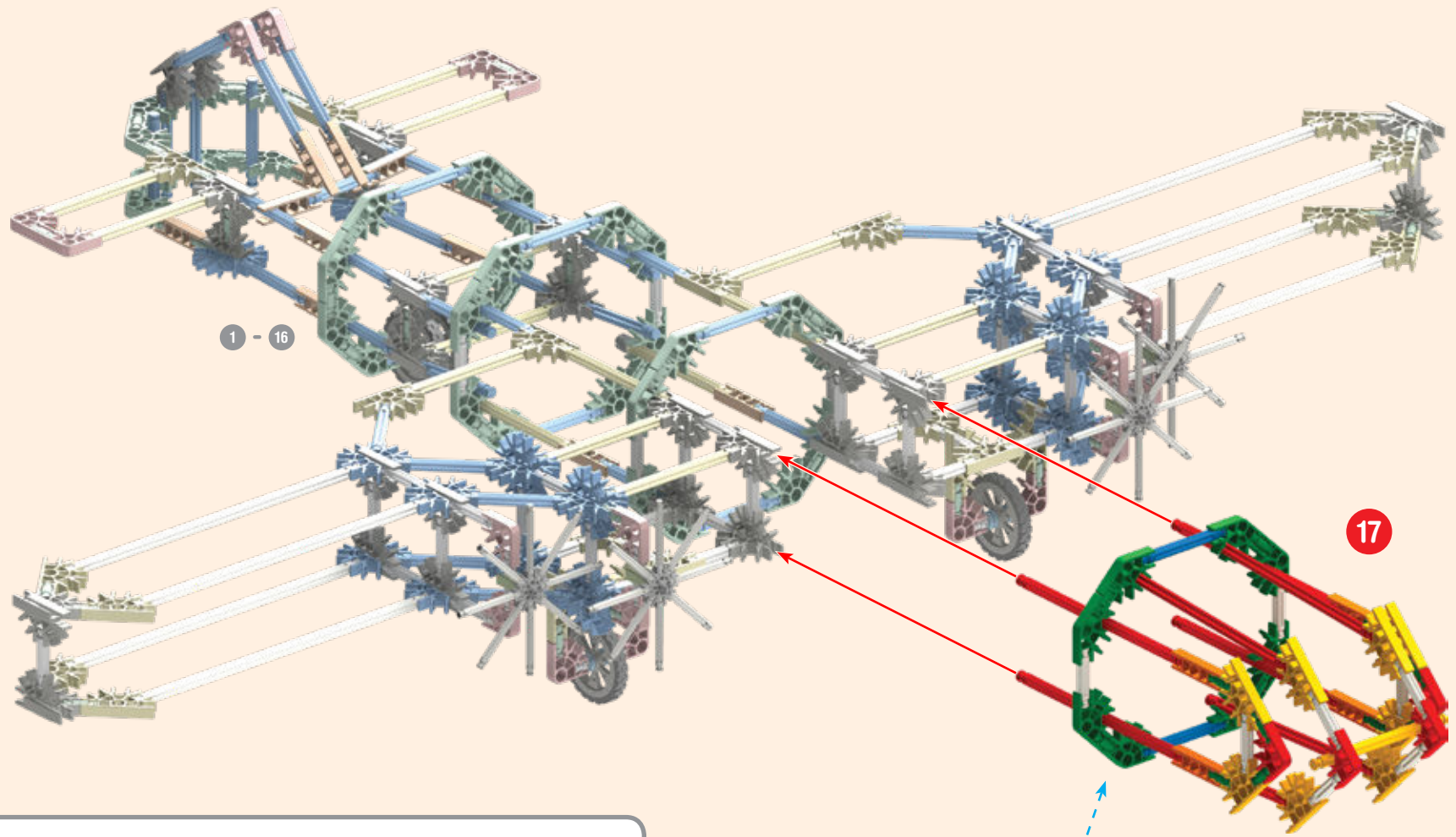

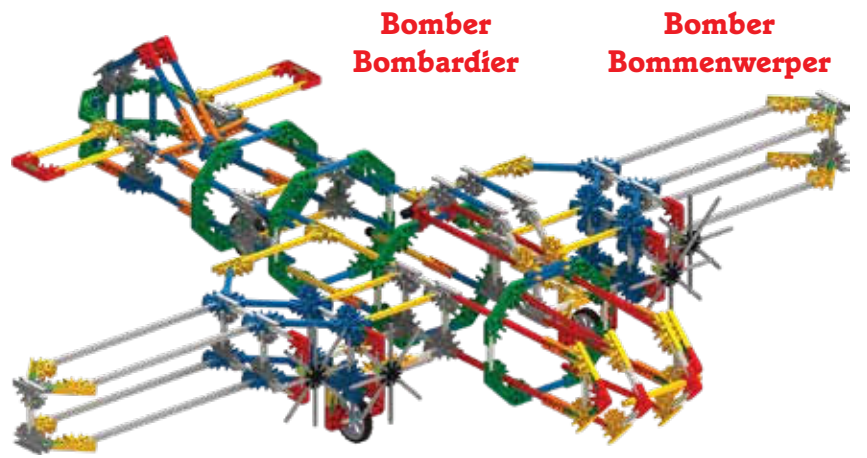
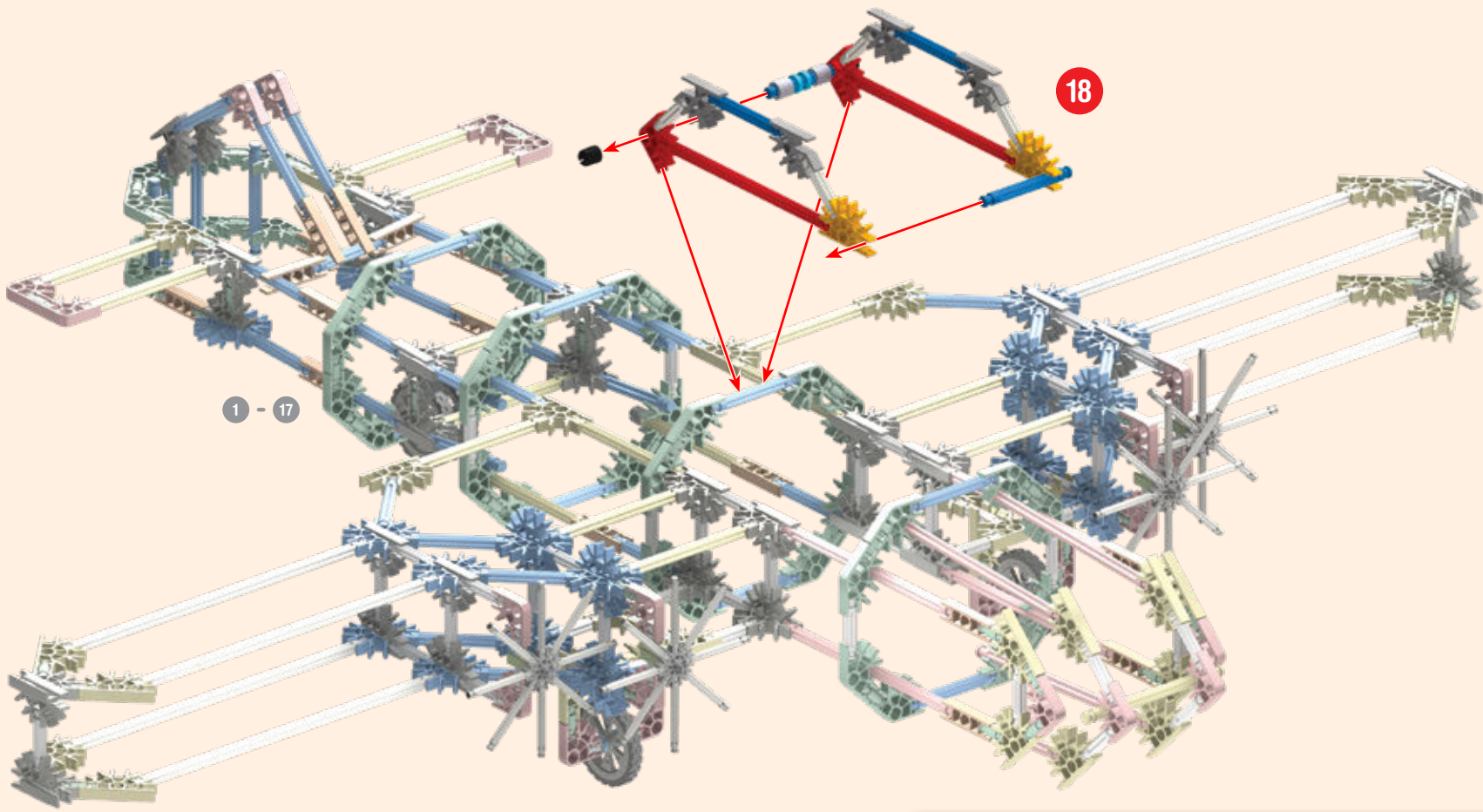

## (ES) ESENCIALES DE CONSTRUCCIÓN K'NEX

(Página 1)

### 1. Para Comenzar a Construir

Para comenzar el modelo, encuentre el número 1 del paso y siga los números. Cada pieza tiene su propia forma y color. Observe las imágenes, encuentre las piezas que sean iguales a las que se muestran y conéctelas. Colocar el modelo en la misma dirección que se encuentra en las instrucciones le facilitará la construcción. Las flechas muestran en dónde se conectan las piezas, pero no todos los puntos de conexión tienen flechas. Las partes de color enue son las que ya armó.

### 2. Separadores

Hay sitios en el modelo en los que necesita utilizar separadores. Asegúrese de usar el número correcto de separadores que se muestra en las instrucciones.

### 3. Conectores

Puede unir estos conectores especiales deslizándolos Presione con fuerza hasta que oiga un "clic". Preste especial atención a las instrucciones y colóquelos de forma horizontal o vertical, exactamente como se muestra.

### 4. Lista de Piezas

Antes de comenzar a construir, compare las piezas de su juego con las que se enumeran aquí. Si falta algo, llámenos o escríbanos utilizando la información que se encuentra en el reverso. ¡Estamos aquí para ayudarle!

(Página 3)

Car les instructions de ces modèles vont à [www.knex.com/instructions](http://www.knex.com/instructions) et entrez dans le code **13465**.

## (IT) ISTRUZIONI DI BASE PER COSTRUIRE CON K'NEX

(Pagina 1)

### 1. Comincia a Costruire

Per iniziare il modello, cerca il numero 1 e segui i numeri. Ogni pezzo ha una sua forma e un suo colore. Guarda la figura, trova i pezzi corrispondenti nel set e mettili insieme. Cerca di tenere il modello nella stessa direzione della figura e in tal modo sarà più semplice attaccare i pezzi nei posti giusti. I colori spenti ti dicono che questa sezione è già stata costruita. Dovrai collegare la nuova sezione al punto indicato dalla punta della freccia.

### 2. Spaziatori

Ci sono punti nel tuo modello a cui dovrai aggiungere spaziatori blu e argento. Accertati di contarli attentamente.

### 3. Connettori

È molto importante posizionare i connettori blu e argento in una specifica direzione. Spingi con forza fino ad udire un "clic". Presta molta attenzione alle istruzioni e posiziona i connettori orizzontalmente o verticalmente proprio come illustrato.

### 4. Elenco delle Parti

Prima di cominciare a costruire, accertati di confrontare le parti che sono nel tuo set con l'elenco delle parti qui. Se ne manca una chiamaci o scrivici usando le informazioni che sono nella retrocopertina. Noi siamo qui per aiutarti!

(Pagina 3)

Per istruzioni di questi modelli vai a [www.knex.com/instructions](http://www.knex.com/instructions) e' inserire il codice **13465**.

## (PT) INSTRUÇÕES BÁSICAS PARA MONTAR O K'NEX

(Página 1)

### 1. Comece a Montar

Para começar a montar o modelo, encontre o número do passo e siga os números. Cada peça tem a sua própria forma e cor. Estude as ilustrações, encontre as peças que coincidem com o que você estiver vendo e conecte-as. Fique de frente para o modelo, na mesma direção que as figuras mostradas nas instruções. As setas mostram onde as peças se conectam, mas nem todos os pontos de conexão têm setas. As partes com cores desbotadas são as que você já montou.

### 2. Separadores

Há lugares no modelo onde você precisará usar separadores. Use o número de espaçadores corretos exibidos nas instruções.

### 3. Conectores

Você pode fazer com que estes conectores se deslizem e se conectem. Empurre até ouvir um "clique". Preste atenção às instruções e posicioneos horizontal ou verticalmente exatamente conforme a ilustração.

### 4. Lista das Peças

Antes de começar a montar, compare as partes do seu conjunto com as partes enumeradas aqui. Se houver algo que estiver faltando, ligue ou escreva para nós usando as informações na capa de trás. Estamos aqui para servir e ajudar!

(Página 3)

Para obter instruções destes modelos vá em [www.knex.com/instructions](http://www.knex.com/instructions) e digite o código **13465**.



**52 MODEL BUILDING SET**  
**52 MODÈLE**  
**JEU DE CONSTRUCTION**



**SCIENCE/SCIENCE**  
**TECHNOLOGY/TECHNOLOGIE**  
**ENGINEERING/INGÉNIERIE**  
**ART & DESIGN/ART ET DESIGN**  
**MATH/MATHÉMATIQUES\***

**knex.com**

@knex

facebook.com/knex

(EN) Keep this important information for future reference.  
 (FR) Gardez précieusement cette notice pour vous y référer ultérieurement.  
 (ES) Guarde esta información importante para futuras referencias.  
 (DE) Informationen für später aufbewahren.  
 (IT) Conservare queste importanti informazioni per riferimento futuro.  
 (PT) Manter esta informação importante para referência futura.  
 (NL) Bewaar deze belangrijke informatie, zodat u deze in de toekomst opnieuw kunt raadplegen.

**CAUTION:** Use care where you use these models. Models could damage furniture or walls, or injure people or pets.  
**ATTENTION :** Utilisez des soins là où vous utilisez ce modèles. Modèles pourrait endommager les meubles ou les murs, ou blesser des personnes ou des animaux domestiques.  
**PRECAUCIÓN:** Tenga mucho cuidado cuando se utiliza este modelos. Modelos podría dañar los muebles o las paredes, o lesionar a personas o animales.  
**VORSICHT:** Seien Sie vorsichtig, wo Sie diese Modelle zu verwenden. Die

Modelle könnten Möbel und Wände beschädigen oder Personen und Haustiere verletzen.  
**AVVERTENZA:** Fare attenzione dove usi questi Modeli. Questi modelli potrebbero fare danno a pareti, o far male a persone o animali.  
**CUIDADO:** Tenha cuidado onde você usa esses modelos. Modelos podem danificar móveis ou paredes, ou ferir pessoas ou animais de estimação.  
**VOORZICHTIG:** Wees voorzichtig waar u deze modellen te gebruiken. Modellen kunnen meubels of muren beschadigen of verwonden mensen of dieren.

**WARNING:** CHOKING HAZARD – Small parts. Not for children under 3 years.  
**ATTENTION :** RISQUE D'ÉTOUFFEMENT – Pièces de petite taille. Ne convient pas aux enfants de moins de 3 ans.  
**ADVERTENCIA:** PELIGRO DE ASFIXIA – Piezas pequeñas. No para niños menores de 3 años.  
**ACHTUNG:** ERSTICKUNGSGEFAHR – Kleinteile. Nicht geeignet für Kinder unter 3 Jahren.  
**AVVISO:** PERICOLO DI SOFFOCARE – Pezzi piccoli. Non adatto per bambini sotto 3 anni.  
**AVISO:** PERIGO DE SUFOCAÇÃO – Peças pequenas. Não se destina a crianças com menos de 3 anos de idade.  
**WAARSCHUWING:** VERSTIKINGSGEVAAR – Kleine onderdelen. Niet geschikt voor kinderen jonger dan 3 jaar.

**CAUTION:** Keep hands, face, hair and clothing away from all moving parts.  
**ATTENTION :** Garde les cheveux, les doigts, la figure et les vêtements à l'écart de toutes les pièces mobiles.  
**PRECAUCIÓN:** Mantén el cabello, los dedos, la cara y la ropa alejada de las piezas móviles.

**VORSICHT:** Haare, Finger, Gesicht und Kleidungsstücke nicht mit beweglichen Teilen in Berührung kommen lassen.  
**ATTENZIONE:** Tenere i capelli, le dita, il viso e i vestiti lontano da tutte le parti in movimento.

**CUIDADO:** Mantém o cabelo, os dedos, a cara e a roupa afastados de todas as peças móveis.  
**LET OP:** Hou het haar, de vingers, het gezicht en kledij verwijderd van alle bewegende onderdelen.

\*Juego inspirado  
 Inspiriertes Spiel  
 Ha ispirato il gioco  
 Inspirou o jogo  
 Geïnspireerd spel

#Ciencia/Wissenschaft/  
 Scienza/Ciência/Wetenschap  
 Tecnologia/Technologie/  
 Tecnologia/Tecnologia/  
 Technologie  
 Ingeniería/Ingenieurwesen/  
 Ingegneria/Engenharia/  
 Bouwkunde  
 Arte Y Diseño/Kunst/design/  
 Arte E Design/Design de arte/  
 kunst En Ontwerp  
 Matemáticas/Mathematik/  
 Matematica/Matemática/  
 Wiskunde

©2018 K'NEX, a Division of Basic Fun, Inc., P.O. Box 700, Hatfield, PA 19440-0700; 1-800-KID-KNEX (USA/Canada/États-Unis/EE.UU.); email@knex.com; knex.com. K'NEX UK Ltd., 200 Brook Drive, Green Park, Reading, RG6 2UB England; K'NEX France, 24 rue du Quatre Septembre, 75002 Paris, France.  
 (EN) For customers outside the USA/Canada please contact your local distributor at [www.knex.com/distributors](http://www.knex.com/distributors)  
 (FR) Pour les clients en dehors du Canada et des États-Unis, veuillez contacter votre distributeur local que vous pouvez trouver sur [www.knex.com/distributors](http://www.knex.com/distributors)  
 (ES) Para clientes fuera de los EE.UU. y Canadá, por favor póngase en contacto con su distribuidor local en [www.knex.com/distributors](http://www.knex.com/distributors)  
 (EN) K'NEX and Steamagination are registered trademarks and Imagine is a trademark of Basic Fun, Inc.  
 (FR) K'NEX et Steamagination sont des marques déposées et Imagine e marque de Basic Fun, Inc.  
 (ES) K'NEX y Steamagination son marcas registrada y Imagine es una marca de K'NEX Basic Fun, Inc.

(EN) Product & colors may vary. Most models can be built one at a time.  
 (FR) Le produit et ses couleurs peuvent varier. Les différents modèles ne peuvent être construits qu'un par un.  
 (ES) El producto y los colores pueden variar. La mayoría de los modelos se pueden construir uno a la vez.  
 (DE) Produkte und Farben können abweichen. Die meisten Modelle können immer nur einzeln gebaut werden.  
 (IT) Prodotti e colori possono differire. La maggior parte dei modelli si può costruire autonomamente.  
 (PT) O produto e as cores podem variar. A maioria dos modelos pode ser montado um de cada vez.  
 (NL) Product en kleuren kunnen variëren. De meeste modellen kunnen uitsluitend een voor een worden gebouwd.



**Download Our App**  
**Téléchargez notre application**  
**Descargue nuestra aplicación**  
**Lade unser App**  
**Scarica il nostro App**  
**Faça o download do nosso aplicativo**  
**Download onze app**

113465-V4-08/18

